



### LONGEVITY

- Wear resistance characteristics of HARDOX maximizes the life-time of the base-plate.
- Open-style construction of the base-plate prevents the stones from getting stuck, thus reducing the wear & tear.

### DURABILITY

- Robust all-around protection cage with solid one-point lift.

### COMFORT

- Low levels of hand arm vibration is made possible by the vibration damping solution.

### PRACTICAL

- Easy-open flaps to access daily check points like fuel tank cap, filter.

## TECHNICAL DATA

### MASSES

Operating mass 743 lbs

### DIMENSIONS

Compaction width 23.6 in

### COMPACTION

Centrifugal force 12,365 lbs

Frequency 4,320 bpm

### PROPULSION

Max. gradeability 20 %

Max. working speed 82 fpm

### ENGINE

Manufacturer/Model Honda GX390

Emissions according to StageV & US EPA

Fuel type Petrol

Fuel tank capacity 1.6 gal

Power 8.6 hp

### DRIVE SYSTEM

Drive system Mechanical

Find us locally at [www.dynapac.us](http://www.dynapac.us)

We reserve the right to change specifications without notice. Photos and illustrations do not always show standard versions of machines. The above information is a general description only, all informations are supplied without liability.



### LONGEVITY

- Wear resistance characteristics of HARDOX maximizes the life-time of the base-plate.
- Open-style construction of the base-plate prevents the stones from getting stuck, thus reducing the wear & tear.

### DURABILITY

- Robust all-around protection cage with solid one-point lift.

### COMFORT

- Low levels of hand arm vibration is made possible by the vibration damping solution.

### PRACTICAL

- Easy-open flaps to access daily check points like fuel tank cap, filter.

## DIMENSIONS

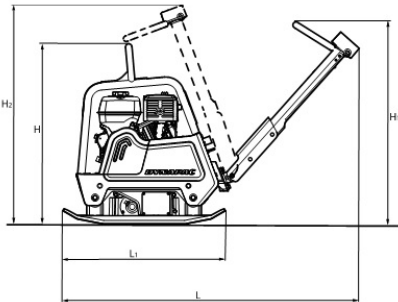

### DIMENSIONS

H. Height	38.7 in
H1. Height	39.6 in
H2. Height	48.2 in
L. Length	65.0 in
L1. Length	34.8 in
W. Basic plate width	23.6 in
W1. Machine width	20.9 in

### STANDARD EQUIPMENT

- Comfort control handle with vibration isolation
- Control lever lock in transport position
- Reverse drive protection
- Highly wear resistant hardox base plate
- Protection hood
- All around protection for V-belt
- One point lift
- Recoil starter

Find us locally at [www.dynapac.us](http://www.dynapac.us)

We reserve the right to change specifications without notice. Photos and illustrations do not always show standard versions of machines. The above information is a general description only, all informations are supplied without liability.