

New FAE 200/U forestry mulcher for PT-300

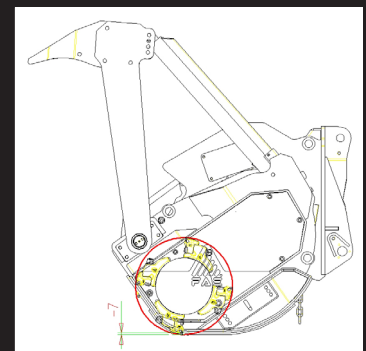

The FAE **200/U** mulching head for PT-300 is the ideal choice for any land clearing job, including vegetation management and ROW clearing. It is built very robust to be used for very heavy-duty jobs. Due to its spiral rotor design it reduces vibrations, absorbs less power, and increases productivity.

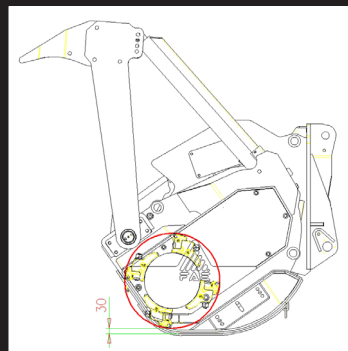

1. Reinforced side cover with extra new wear-resistant plate
2. Shorter and stronger hood
3. Hydraulic hoses of rear hood and guard frame integrated in the frame
4. Adjustable skids
5. Redesigned guard frame with improved mounting system and bigger cylinders with protected hoses.



6. Easily interchangeable counter blades (up to 3 lines), made of wear-resistant steel

7. Bolt-on plates made of Hardox and weld-on highly wear-resistant plates made of anti-wear steel alloys, ensure a greater resistance to wear and keep maintenance costs low



8

8. New raker teeth on guard frame. To drag logs and material and can be used as guide pins.

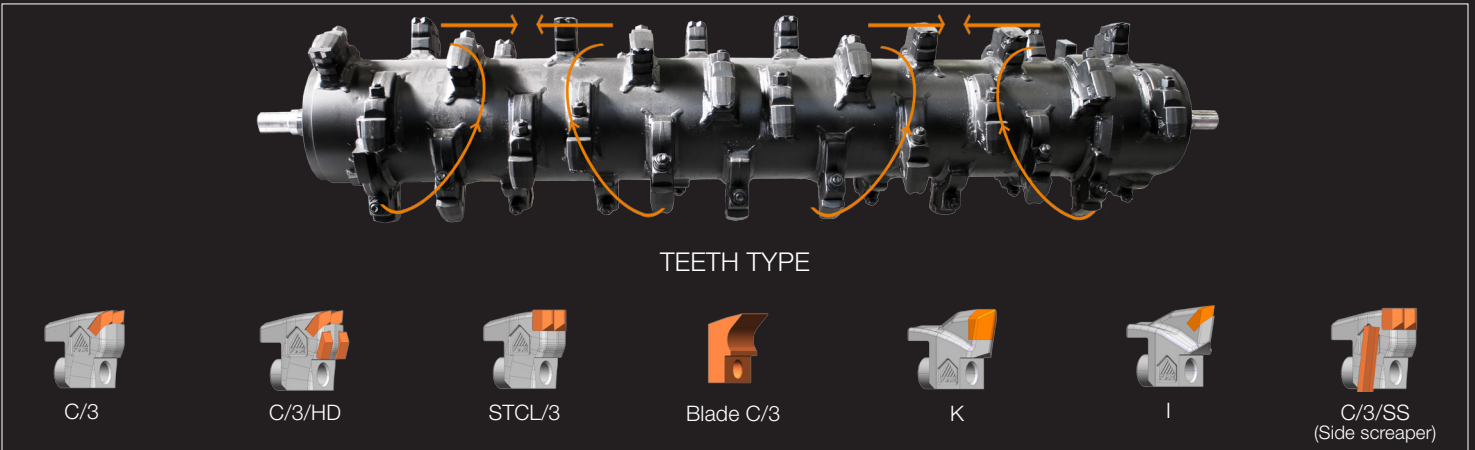

The double spiral rotor design ensures even distribution of the power over the entire width of the rotor, limits stresses to the structure, absorbs less power and enables even distribution of the mulched material. Wide range of interchangeable teeth are available for different working conditions.

TECHNICAL SPECIFICATIONS

> 200/U						
MODEL	200/U-200		200/U-210		200/U-225	
• Rotor diameter	20 in	500 mm	20 in	500 mm	20 in	500 mm
• Overall width	97 in	2475 mm	101 in	2560 mm	107 in	2714 mm
• Working width	81 in	2060 mm	85 in	2150 mm	90 in	2300 mm
• Weight with options	6239 lbs	2830 kg	6349 lbs	2880 kg	6460 lbs	2930 kg
• Max. working depth	3 in	80 mm	3 in	80 mm	3 in	80 mm
• Grinding diameter (max)	14 in	350 mm	14 in	350 mm	14 in	350 mm
• Quantity of cutting teeth tungsten carbide type "C/3"	42 + 2		44 + 2		46 + 2	
• Rotor rpm	2325		2325		2325	
• Hydraulic motor type (2)	Danfoss	110 cc	Danfoss	110 cc	Danfoss	110 cc

FAE Group S.p.A. - PrimeTech Division

Via G. Marconi, 20 // 38011 Sarnonico (TN) // Italy // Tel. +39 0463 840 080 // Fax +39 0463 840 099

PrimeTech Shredding Equipment Ltd. - Branch Office

110 Saskatchewan Ave - Spruce Grove, AB, T7X 3B4 // Canada // Tel. 780-948-8882 // Fax 780-948-8886

www.primetech.com // info@prime-tech.com



a brand of FAE Group