

# GRADALL®

## XL 3100 V

### HYDRAULIC EXCAVATOR



## SPECIFICATIONS

### Engine

- Volvo TAD572VE Tier 4f 5.1L diesel with selective catalytic reduction and cooled EGR technology
- Gross Rating:** 215 hp @ 2300 rpm, 660 ft lb torque @ 1200-1700 rpm
- Net Rating:** 198 hp @ 2300 rpm
- Four cycle, inline four cylinder, liquid cooled
- Turbo charge air after-cooled
- Off-road certified, electronically controlled, grid heater
- Vertical canister style lube and main filters attached to engine
- Volvo remote mount vertical style fuel/water separator with water in fuel indicator, alarm and manual feed pump
- Block heater

- Air Filter**
- Two-stage Donaldson PSD PowerCore with high efficiency pre-cleaner, vacuator valve and remote service indicator

- Electrical System**
- 24 volt, 110 amp alternator with integral voltage regulator, two SAE #C31-S 1000 CCA batteries

**Fuel Tank Capacity:** 100 gal (378 L)

**Urea Tank Capacity:** 11.9 gal (45 L)

- Chassis Cooling Package**
- Three aluminum bar-plate type coolers stacked vertically
  - Air to air intake charge air cooler, radiator and transmission cooler
  - All coolers backed by a molded fan shroud, engine mounted fan ring and 26.8" 9-blade fan driven by a Volvo electronically controlled variable speed fan drive

**Gear Speeds**

Gear	1	2	3	4	5	6	REV
<b>MPH</b>	6.5	15.5	22.7	34.9	46.6	60.0	6.3
<b>Km/hr</b>	(10.4)	(25.0)	(36.5)	(56.1)	(75.0)	(96.6)	(10.1)

- Drivelines**
- Spicer 1710 Series with "half round" yokes

- Transfer Case**
- (6 x 4) Cushman Model 479-1, 1:1 ratio, pneumatic engage for remote propel
  - (6 x 6) Cushman Model 479A-1, 1:1 ratio, pneumatic engage for remote propel and front drive

### Upperstructure Cab

- All-weather cab isolated from frame on rubber mounts
- Tinted safety glass windows
- Skylight
- Acoustical lining
- Four-way adjustable seat
- Dome light
- Filtered air heater and defroster
- AM/FM radio
- Air conditioning
- LED work light package
- Heat source provided by a fast response, closed circuit hydraulic heater with 20,000 BTU/Hr. capacity
- Front window slides to overhead storage
- Mirrors on right and left sides
- Windshield wiper and washer
- Operator's seat belt

### Upperstructure Controls

- Two electronic joysticks (hoist and bucket, telescope and swing)
- One rocker switch (tilt) control
- Joysticks mounted on arm pods, adjustable for individual operator comfort and convenience
- Quick change joystick pattern switch (Gradall, SAE, Deere) located on instrument panel
- Two foot pedals for remote control of undercarriage steering
- Travel and digging brakes
- Self-centering joysticks and pedals; when controls are released, power for movement disengages and swing and travel brakes set automatically

- Engine Controls:**
- Key ignition switch with neutral start
  - Indicator lights for low air, engine status, park brake, travel status, hydraulic fluid temperature and level
  - Automatic engine shutdown occurs with low oil pressure
  - Derate/shutdown for oil temperature, coolant temperature, coolant level, ERD temperature, charge air temperature, charge air pressure and derate for SCR temperature

### Boom

- Two piece triangular telescoping boom
- Adjustable boom rollers with eccentric shafts
- 220° boom tilt
- 105° boom pivot angle
- Auxiliary hydraulics

### Hydraulic System

- Pumps**
- One load-sensing axial piston pump, 0-77 gpm (0-291 L/min) total
  - One gear pump (pilot and cooling), 11 gpm (41 L/min)

- SYSTEM SPECIFICATIONS**
- Four Double Acting Cylinders**
- Two hoist cylinders: 3.5" x 2.56" rod x 31" stroke (89 mm x 65 mm x 787 mm)
  - One tool cylinder: 4.25" bore x 3.0" rod x 25.9" stroke (108 mm x 76 mm x 658 mm)
  - One telescope: 3.5" ID x 2.559" rod x 11' stroke (89 mm x 65 mm x 3.34 m)

- Three Hydraulic Motors**
- Swing, 51 hp (38kW)
  - Tilt, 21 hp (16 kW)
  - Remote drive, 110 hp (82 kW) total

- Operating Pressures**
- Hoist.....4,800 psi (331 BAR)
  - Tilt.....2,500 psi (172 BAR)
  - Swing.....4,200 psi (290 BAR)
  - Tool.....4,800 psi (331 BAR)
  - Telescope.....4,800 psi (331 BAR)
  - Remote Propel.....4,800 psi (331 BAR)
  - Pilot system.....550 psi (38 BAR)

- Oil Capacity**
- Reservoir 50 gallons (189 L)
  - System 65 gallons (246 L)
  - Pressurized reservoir with visual oil level gauge

- Filtration System**
- 5 micron return filter with magnet
  - 10 micron pilot filter
  - Fin and tube-type oil cooler with thermostatically controlled cooling fan
  - Pressure-compensated, load-sensing valves with circuit reliefs in all circuits

## Undercarriage

- 4 x 2 or 4 x 4
- Wheelbase: 160" (4.06m)
- Width 102" (2.6m)

### Transmission

- Allison 3500 RDS 6-speed automatic

### Frame

- 48" (1.2m) wide, welded plate design
- 65 ksi material

### Gross Vehicle Axle Weight Rating:

- 4 x 2 - 41,250 lb (18,711 kg)
- 4 x 4 - 44,250 lb (20,071 kg)

### Front Axles

- 4 x 2: Meritor Model MFS-16-122A, 16,000 lb (7,257 kg) rating
- 4 x 4: Meritor Model MX19-145, 19,000 lb (8,618 kg) rating, 7.17 ratio

### Rear Axle

- Meritor Model RS25-160, 25,250 lb (11,453 kg) rating, 7.17 ratio
- Single reduction with driver controlled differential lock in front/rear
- Inter-axle differential with lock

### Suspension

- Front: Eight leaf spring with automatic lock-out cylinders
- Rear: Solid mount

### Brakes

- 4 x 2 Front: Meritor "Q" Series
  - Cam-Master Size: 16.5" x 5" (419 mm x 152 mm)
  - Automatic slack adjusters
- 4 x 4 Front: Meritor "Q" Series
  - Cam-Master Size: 16.5" x 6" (419 mm x 127 mm)
  - Automatic Slack Adjusters.
- Rear: Meritor "P" Series
  - Series Cam-Master Size: 16.5" x 7" (419 mm x 178 mm)
  - Automatic slack adjusters
- Spring brake system incorporates emergency and parking brakes on rear axle
- Heated air dryer

### Steering

- Ross, integral hydraulic power steering
- Gear-type power steering pump
- Four-quart power steering reservoir with filter
- 10 micron pre-filter

### Wheels

- Hub piloted disc
- 10-stud, 11.25" (286 mm) bolt circle

### Tires

- 4 x 4 front: 425/65R22.5 LR (L) on/off highway traction tread
- 4 x 2 front: 385/65R22.5 LR (J) on/off highway tread
- 4 x 2 and 4 x 4 rear: 11R24.5 LR (H) on/off highway traction tread

### Standard Chassis Equipment

- LED headlights
- LED tail lights
- LED back-up lights and alarm
- LED brake lights
- LED identification lights front and rear
- LED directional lights
- LED four-way hazard lights
- Instrument panel lights
- Windshield wiper/washer
- West Coast style mirror system with plain and convex mirrors
- Front and rear tow hooks
- Desiccant type air dryer with automatic purge valve and thermostatically controlled heater

## Chassis Cab

- One-person cab
- Left-hand mount
- Isolated from frame on rubber mounts
- Acoustical lining
- Sun visor
- Air conditioning

### Gauge Clusters

- Oil pressure
- Coolant temperature
- Air tank pressures
- Fuel level
- DEF level

- Voltmeter
- Speedometer with odometer
- Tachometer with hour meter
- Engine and transmission monitor lights
- Engine shutdown controlled by engine electronics
- Indicator lights and controls for front axle engagement (4 x 4 only) and rear axle differential lock
- Park brake control
- Tinted safety glass
- Sliding side windows
- Fresh air heater and defroster
- Dome light
- Air suspension seat with seat belt
- Vent in door

## Swing

- Internal swing gear
- Priority swing circuit with axial piston motor
- Planetary transmission

**Swing Speed:** 8.0 rpm

### Swing Brake:

- Automatic spring-set/hydraulic release wet disc parking brake
- Dynamic braking provided by hydraulic system

## Hydraulic Remote Control

- Upperstructure powered by chassis hydraulics through hydraulic motor and transfer case
- Travel and steering pedals in upperstructure cab
- Digging brakes and front axle lockout cylinders set automatically with travel pedal in neutral
- Parking brake controlled by toggle
- Electrically operated alarm mounted on undercarriage signals remote control movement in either direction, reverse movement when driven from undercarriage cab

## Function Forces

**Rated Boom Force:** 21,940 lb (97.6kN)

**Rated Bucket Breakout Force:** 17,990 lb (80kN)

### GRADALL Model XL 3100 V Lift Capacity Over Side or Rear - LBS (KG.)

LOAD POINT HEIGHT		LOAD RADIUS								
		10' 0" (3.0 m)		15' 0" (4.6 m)		20' 0" (6.1 m)		Max. radius		
		Over End	Over Side	Over End	Over Side	Over End	Over Side		Over End	Over Side
ABOVE GROUND LEVEL	20' 0" (6.1 m)							20' 2" (6.1 m)	3625 (1645)	3625 (1645)
	15' 0" (4.6 m)			6475 (2935)	6475 (2935)	4320 (1960)	4320 (1960)	22' 8" (6.9 m)	3545 (1610)	3545 (1610)
	10' 0" (3.0 m)			7655 (3470)	7655 (3470)	4890 (2220)	4890 (2220)	24' 0" (7.3 m)	3560 (1615)	3560 (1615)
	BOOM LEVEL 8' 6" (2.6 m)			7840 (3555)	7840 (3555)	4975 (2255)	4975 (2255)	24' 2" (7.4 m)	3575 (1620)	3575 (1620)
	5' 0" (1.5 m)			7870 (3570)	7870 (3570)	5050 (2290)	5050 (2290)	24' 2" (7.4 m)	3625 (1645)	3625 (1645)
AT GROUND LEVEL				6840 (3105)	6840 (3105)	4710 (2135)	4710 (2135)	23' 3" (7.1 m)	3720 (1685)	3720 (1685)
BELOW GROUND LEVEL	5' 0" (1.5 m)	5920 (2685)	5920 (2685)	5920 (2685)	5920 (2685)	4030 (1830)	4030 (1830)	21' 0" (6.4 m)	3785 (1715)	3785 (1715)
	15' 0" (4.6 m)	3590 (1630)	3590 (1630)	3860 (1750)	3860 (1750)			16' 11" (5.1 m)	3665 (1660)	3665 (1660)
	10' 0" (3.0 m)							9' 9" (3 m)	2155 (975)	2155 (975)

The rated lift capacity is based on the machine being equipped with 6,000 lb (2720 kg) counterweight, standard boom, standard tires, no auxiliary hydraulics and no bucket.

**NOTE:** Bucket adjustment values are 87% of the actual bucket weights.

The load point is located on the bucket pivot point, including load listed for maximum radius.

Do not attempt to lift or hold any load greater than these rated values at specified load radii and heights. The weight of slings and any auxiliary devices must be deducted from the rated load to determine the net load that may be lifted.

**ATTENTION:** All rated loads are based on the machine being stationary and level on a firm supporting surface. For safe working loads, the user must make allowance for his particular job conditions such as soft or uneven ground, out of level conditions, side loads, hazardous conditions, experience of personnel, etc. The operator and other personnel must fully acquaint themselves with the Operator's Manual furnished by the manufacturer before operating this machine. Rules for safe operation of equipment must be adhered to at all times.

**NOTE:** The above loads are in compliance with the SAE standard J1097 DEC2005. They do not exceed 87% of hydraulic lifting capacity or 75% of tipping capacity.

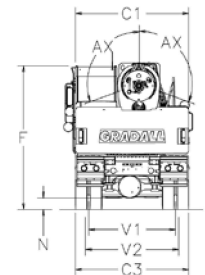
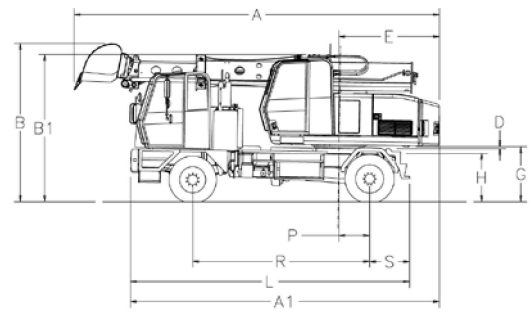
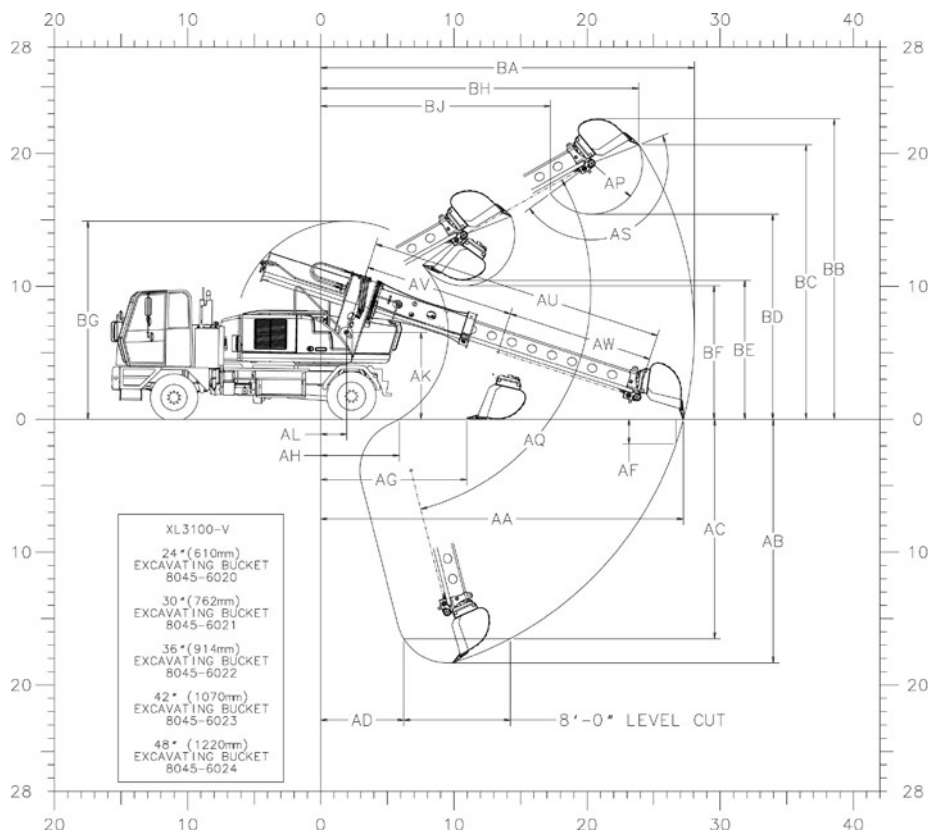

## Dimensions

	4 x 2	4 x 4		4 x 2	4 x 4		
<b>A</b>	27' 6" (8.4)	27' 6" (8.4)	Overall length (boom in rack) with bucket	<b>AG</b>	11' 0" (3.3)	10' 11" (3.3)	Minimum level cut radius with bucket flat on ground line
<b>A1</b>	23' 3" (7.1)	23' 3" (7.1)	Overall length (boom in rack) without bucket	<b>AH</b>	5' 11" (1.8)	5' 4" (1.6)	Minimum radius at ground line
<b>B</b>	11' 11" (3.6)	12' 3" (3.7)	Overall height (boom in rack) with bucket	<b>AK</b>	6' 6" (2.0)	6' 10" (2.1)	Boom pivot to ground line
<b>B1</b>	11' 1" (3.4)	11' 5" (3.5)	Overall height (boom in rack) without bucket	<b>AL</b>	23" (596 mm)	23" (596 mm)	Boom pivot to axis of rotation
<b>C1</b>	8' 6" (2.6)	8' 6" (2.6)	Width of upper structure	<b>AP</b>	46" (1.2)	46" (1.2)	Bucket tooth radius
<b>C3</b>	8' 6" (2.6)	8' 6" (2.6)	Width of undercarriage	<b>AQ</b>	30° Up & 75° Down	30° Up & 75° Down	Boom pivot angle
<b>D</b>	2" (45 mm)	2" (45 mm)	Minimum clearance, upperstructure to undercarriage	<b>AS</b>	165°	165°	Bucket pivot angle
<b>E</b>	7' 6" (2.3)	7' 6" (2.3)	Swing clearance, rear of upperstructure	<b>AU</b>	22' 3" (6.8)	22' 3" (6.8)	Maximum telescoping boom length (boom pivot to bucket pivot)
<b>F</b>	10' 10" (3.3)	11' 1" (3.4)	Top of cab to ground line	<b>AV</b>	11' 3" (3.4)	11' 3" (3.4)	Minimum telescoping boom length (boom pivot to bucket pivot)
<b>G</b>	50" (1.3)	54" (1.4)	Clearance, upperstructure to ground line	<b>AW</b>	11' 0" (3.4)	11' 0" (3.4)	Telescoping boom travel
<b>H</b>	44" (1.1)	47" (1.2)	Top of wheel mounted undercarriage frame to ground line	<b>AX</b>	110°	110°	Bucket tilt angle (both sides of center)
<b>L</b>	21' 0" (6.4)	21' 0" (6.4)	Overall length of undercarriage	<b>BA</b>	28' 1" (8.6)	28' 1" (8.6)	Maximum radius of working equipment
<b>N</b>	10" (254 mm)	10" (254 mm)	Ground clearance (per SAE J1234)	<b>BB</b>	22' 7" (6.9)	22' 11" (7.0)	Minimum clearance of bucket teeth, with bucket pivot at maximum height
<b>P</b>	28" (701 mm)	28" (701 mm)	Center of rear axle to axis of rotation	<b>BC</b>	20' 8" (6.3)	21' 0" (6.4)	Maximum bucket tooth height
<b>R</b>	13' 4" (4.1)	13' 4" (4.1)	Wheel base	<b>BD</b>	15' 5" (4.7)	15' 9" (4.8)	Minimum clearance of bucket teeth, with bucket pivot at maximum height
<b>S</b>	36" (916 mm)	36" (916 mm)	Center of rear axle to rear of frame (step)	<b>BE</b>	10' 5" (3.2)	10' 9" (3.3)	Minimum clearance of fully curled bucket at maximum boom height
<b>V1</b>	6' 6" (2.0)	6' 6" (2.0)	Tread, rear axles 4 x 4 (10:00 x 20 tires), 4 x 2 (Spoke Wheels)	<b>BF</b>	10' 1" (3.1)	10' 4" (3.2)	Minimum clearance of bucket teeth at maximum boom height
<b>V2</b>	7' 0" (2.1)	7' 0" (2.1)	Tread, front axle 4 x 4 (15:00 x 22.5 tires), 4 x 2 (Spoke Wheels)	<b>BG</b>	14' 11" (4.5)	15' 2" (4.6)	Maximum height of working equipment with bucket below ground line
<b>AA</b>	27' 3" (8.3)	27' 2" (8.3)	Maximum radius at ground line (165° pivot)	<b>BH</b>	23' 11" (7.3)	23' 11" (7.3)	Radius of bucket teeth at maximum height
<b>AB</b>	18' 4" (5.6)	18' 1" (5.5)	Maximum digging depth (165° pivot)	<b>BJ</b>	17' 3" (5.3)	17' 3" (5.3)	Minimum radius of bucket teeth at maximum bucket pivot height
<b>AC</b>	16' 6" (5.0)	16' 3" (4.9)	Maximum depth for 8' level cut				
<b>AD</b>	6' 3" (1.9)	6' 3" (1.9)	Maximum radius of 8' level cut at depth "AC"				
<b>AF</b>	1' 10" (0.6)	1' 10" (0.6)	Maximum depth of vertical wall which can be excavated				

Specifications subject to change without notice.  
Metric units are meters (m) unless noted.  
Machines shown may have optional equipment.

## Weight

- Approximate working weight, including 30" (762 mm) bucket, fuel tank half full.
- 4 x 2: 40,930 lb (18,566 kg)
- 4 x 4: 41,720 lb (18,924 kg)

## Optional Equipment

- Vandalism protection kit including window covers
- Strobe light
- Tilt steering column

## Attachments

- Quick change and reversible buckets fabricated using steel plate with high strength, low alloy cutting edges and wear strips
- Standard attachments available for wide range of applications
- Capacities shown are in heaped cubic yard



### Excavating Bucket

		yd <sup>3</sup>	m <sup>3</sup>
8045-6020	24" (610mm) 603 lbs (274 kg)	3/8	0.31
8045-6021	30" (762mm) 660 lbs (300 kg)	1/2	0.41
8045-6022	36" (914mm) 741 lbs (336 kg)	5/8	0.54
8045-6023	42" (1.07m) 841 lbs (382 kg)	3/4	0.64
8045-6024	48" (1.22m) 957 lbs (434 kg)	1	0.76



### Trenching Bucket

		yd <sup>3</sup>	m <sup>3</sup>
8065-6104	15" (381mm) 897 lbs (407 kg)	1/5	0.15
8065-6012	21" (533mm) 982 lbs (445 kg)	1/4	0.19

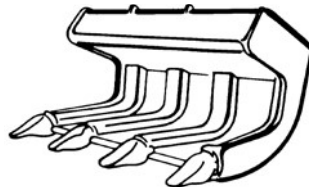

### Pavement Removal Bucket

8065-6102	40" (1.0 m) 1262 lbs (573 kg)		
8065-6115	18" (0.457 m) 929 lbs (421 kg)		
8065-6116	24" (0.610 m) 1,219 lbs (553 kg)		
8065-6114	28" (0.711 m) 1,310 lbs (594 kg)		

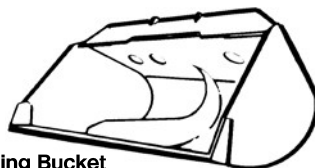

### Ditching Bucket

		yd <sup>3</sup>	m <sup>3</sup>
8065-6040	30" (0.762 m) 521 lbs (236 kg)	3/8	0.3
8065-6007	60" (1.52m) 807 lbs (366 kg)	7/8	0.73
8065-6006	66" (1.68m) 892 lbs (405 kg)	1	0.76
8065-6002	72" (1.83m) 944 lbs (428 kg)	1 1/8	0.87

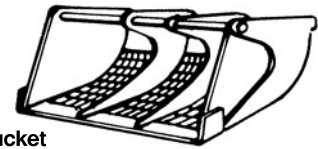

### Dredging Bucket

		yd <sup>3</sup>	m <sup>3</sup>
8065-6013	72" (1.83m) 1114 lbs (505 kg)	1 1/8	0.87

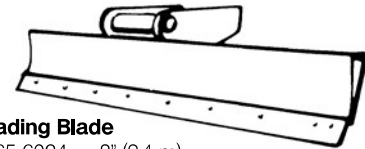

### Grading Blade

8065-6024	8" (2.4 m) 630 lbs (285 kg)		
-----------	--------------------------------	--	--

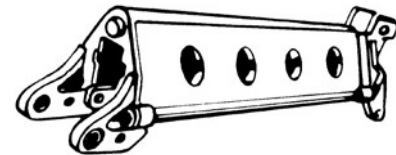

### Boom extension

8065-5028	4' (1.2 m) 1,090 lbs (495 kg)		
-----------	----------------------------------	--	--

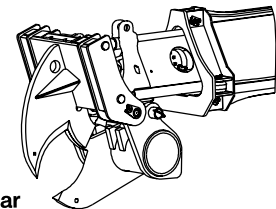

### Tree Limb Shear

8045-5052	1,948 lbs (884 kg)		
-----------	--------------------	--	--

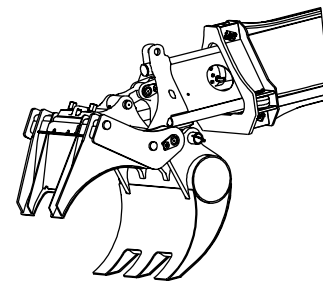

### Fixed Thumb Grapple

8075-5023	1,574 lbs (714 kg)		
-----------	--------------------	--	--

It is Gradall Policy to continually improve its products. Therefore designs, materials and specifications are subject to change without notice and without incurring any liability on units already sold. Units shown may have optional equipment.

# GRADALL®

406 Mill Ave. SW, New Philadelphia, Ohio 44663  
Phone: 330-339-2211 Fax: 330-339-8468  
www.Gradall.com



Form No. 11815 12/19  
Printed in USA