

GRADALL®

XL 4100 V

HYDRAULIC EXCAVATOR



SPECIFICATIONS

Engine

- Volvo TAD871VE Tier 4f 7.7L diesel with selective catalytic reduction and cooled EGR technology

Gross Rating: 248 hp @ 2200 rpm, 848 ft lb torque @ 1200-1400 rpm

Net Rating: 228 hp @ 2200 rpm

- Four cycle, inline six cylinder, liquid cooled
- Turbo charge air after-cooled
- Off-road certified, electronically controlled, grid heater
- Vertical canister style lube and main filters attached to engine
- Volvo remote mount vertical style fuel/water separator with water in fuel indicator, alarm and manual feed pump

Air Filter

- Two-stage Donaldson PSD PowerCore with high efficiency pre-cleaner, vacuator valve and remote service indicator

Electrical System

- 24 volt, 110 amp alternator with integral voltage regulator, two SAE #C31-S 1000 CCA batteries

Fuel Tank Capacity: 100 gal (378 L)

Urea Tank Capacity: 11.9 gal (45 L)

Chassis Cooling Package

- Three aluminum bar-plate type coolers stacked vertically
- Air to air intake charge air cooler, radiator and transmission cooler
- All coolers backed by a molded fan shroud, engine mounted fan ring and 26.8" 9-blade fan driven by a Volvo electronically controlled variable speed fan drive

Gear Speeds

Gear	1	2	3	4	5	6	REV
MPH	6.3	16.2	24.1	37.4	50.6	59.9	6.6
Km/hr	(10.1)	(26.1)	(38.8)	(60.2)	(81.4)	(96.4)	(10.6)

Drivelines

- Spicer 1710 Series with "half round" yokes

Transfer Case

- (6 x 4) Cushman Model 479-1, 1:1 ratio, pneumatic engage for remote propel
- (6 x 6) Cushman Model 479A-1, 1:1 ratio, pneumatic engage for remote propel and front drive

Upperstructure Cab

- All-weather cab isolated from frame on rubber mounts
- Tinted safety glass windows
- Skylight
- Acoustical lining
- Four-way adjustable seat
- Dome light
- Filtered air heater and defroster
- AM/FM radio
- Air conditioning
- LED work light package
- Heat source provided by a fast response, closed circuit hydraulic heater with 20,000 BTU/Hr. capacity
- Front window slides to overhead storage
- Mirrors on right and left sides
- Windshield wiper and washer
- Operator's seat belt

Upperstructure Controls

- Two electronic joysticks (hoist and bucket, telescope and swing)
- One rocker switch (tilt) control
- Joysticks mounted on arm pods, adjustable for individual operator comfort and convenience
- Quick change joystick pattern switch (Gradall, SAE, Deere) located on instrument panel
- Two foot pedals for remote control of undercarriage steering
- Travel and digging brakes
- Self-centering joysticks and pedals; when controls are released, power for movement disengages and swing and travel brakes set automatically

Engine Controls:

- Key ignition switch with neutral start
- Indicator lights for low air, engine status, park brake, travel status, hydraulic fluid temperature and level
- Automatic engine shutdown occurs with low oil pressure
- Derate/shutdown for oil temperature, coolant temperature, coolant level, ERD temperature, charge air temperature, charge air pressure and derate for SCR temperature

Boom

- Two piece triangular telescoping boom
- Adjustable boom rollers with eccentric shafts
- 220° boom tilt
- 105° boom pivot angle

Hydraulic System

Pumps

- One load-sensing axial piston pump, 0-77 gpm (0-291 L/min) total
- One gear pump (pilot and cooling), 11 gpm (41 L/min)

SYSTEM SPECIFICATIONS

Four Double Acting Cylinders

- One boom cylinder: 3.5" (89 mm) bore x 2.56" (65 mm) rod x 150" (3.81 m) stroke
- Two hoist cylinders: 4.25" (108 mm) bore x 3.15" (80 mm) rod x 31" (787 mm) stroke
- One tool cylinder: 5.0" (127 mm) bore x 3.0" (76 mm) rod x 25.9" (658 mm) stroke

Three Hydraulic Motors

- Swing, 64 hp (48 kW)
- Tilt, 21 hp (16 kW)
- Remote drive, 110 hp (82 kW) total

Operating Pressures

- Hoist.....4,800 psi (331 BAR)
- Tilt.....2,500 psi (172 BAR)
- Swing.....4,200 psi (290 BAR)
- Tool.....4,800 psi (331 BAR)
- Telescope.....4,800 psi (331 BAR)
- Remote Propel.....4,800 psi (331 BAR)
- Pilot system.....500 psi (35 BAR)

Oil Capacity

- Reservoir 50 gallons (189 L)
- System 70 gallons (265 L)
- Pressurized reservoir with visual oil level gauge

Filtration System

- 5 micron return filter with magnet
- 10 micron pilot filter
- Fin and tube-type oil cooler with thermostatically controlled cooling fan
- Pressure-compensated, load-sensing valves with circuit reliefs in all circuits

Undercarriage

- 6 x 4 or 6 x 6
- Wheelbase: 171" (4.34m)
- Width 102" (2.6m)

Transmission

- Allison 3500 RDS 6-speed automatic

Frame

- 48" (1.2m) wide, welded plate design
- 65 ksi material

Gross Vehicle Axle Weight Rating:

- 6 x 4 - 66,000 lb (29,937 kg)
- 6 x 6 - 69,000 lb (31,928 kg)

Front Axles

- 6 x 4: Meritor Model MFS-16-122A, 16,000 lb (7,257 kg) rating
- 6 x 6: Meritor Model MX19-145, 19,000 lb (8,618 kg) rating, 7.17 ratio

Rear Axle

- Meritor Model RT-50-160, 50,000 lb (22,680 kg) rating, 7.17 ratio
- Single reduction with driver controlled differential lock in front/rear
- Inter-axle differential with lock

Suspension

- Front: Eight leaf spring with automatic lock-out cylinders
- Rear: Hendrickson Equalizer Beam, 8" oscillation

Brakes

- 6 x 4 Front: Meritor "Q" Plus Series
 - Cam-Master Size: 16.5" x 5" (419 mm x 152 mm)
 - Automatic slack adjusters
- 6 x 6 Front: Meritor "Q" Series
 - Cam-Master Size: 16.5" x 6" (419 mm x 127 mm)
 - Automatic slack adjusters
- Rear: Meritor "P" Series
 - Cam-Master Size: 16.5" x 7" (419 mm x 178 mm)
 - Automatic slack adjusters
- Spring brake system incorporates emergency and parking brakes on rear axle
- Heated air dryer

Steering

- Ross, integral hydraulic power steering
- Gear-type power steering pump
- Four-quart power steering reservoir with filter
- 10 micron pre-filter

Wheels

- Hub piloted disc
- 10-stud, 11.25" (286 mm) bolt circle

Tires

- 6 x 4 front: 385/65R22.5 LR (J) on/off highway tread
- 6 x 6 front: 425/65R22.5 LR (L) on/off highway tread
- 6 x 4 and 6 x 6 rear: 11R24.5 LR (H) on/off highway tread

Standard Chassis Equipment

- LED headlights
- LED tail lights
- LED back-up lights and alarm
- LED brake lights
- LED identification lights front and rear
- LED directional lights
- LED four-way hazard lights
- Instrument panel lights
- Windshield wiper/washer
- West Coast style mirror system with plain and convex mirrors
- Front and rear tow hooks
- Desiccant type air dryer with automatic purge valve and thermostatically controlled heater

Chassis Cab

- One-person cab
- Left-hand mount
- Isolated from frame on rubber mounts
- Acoustical lining
- Sun visor

Gauge Clusters

- Oil pressure
- Coolant temperature
- Air tank pressures
- Fuel level
- DEF level
- Voltmeter

- Speedometer with odometer
- Tachometer with hour meter
- Engine and transmission monitor lights
- Engine shutdown controlled by engine electronics
- Indicator lights and controls for front axle engagement (6 x 6 only) and rear axle differential lock
- Park brake control
- Tinted safety glass
- Sliding side windows
- Fresh air heater and defroster
- Dome light
- Air suspension seat with seat belt
- Vent in door

Swing

- Internal swing gear
- Priority swing circuit with axial piston motor
- Planetary transmission

Swing Speed: 8.0 rpm

Swing Brake:

- Automatic spring-set/hydraulic release wet disc parking brake
- Dynamic braking provided by hydraulic system

Hydraulic Remote Control

- Upperstructure powered by chassis hydraulics through hydraulic motor and transfer case
- Travel and steering pedals in upperstructure cab
- Digging brakes and front axle lockout cylinders set automatically with travel pedal in neutral
- Parking brake controlled by toggle
- Electrically operated alarm mounted on undercarriage signals remote control movement in either direction, reverse movement when driven from undercarriage cab

Function Forces

Rated Boom Force: 21,940 lbs (97.6 kN)

Rated Bucket Breakout Force: 24,900 lbs (111kN)

GRADALL Model XL 4100 V Lift Capacity Over Side or Rear - LBS (KG)

LOAD POINT HEIGHT		LOAD RADIUS								Max. radius		
		10' 0" (3.0 m)		15' 0" (4.6 m)		20' 0" (6.1 m)		25' 0" (7.6 m)			Over End	Over Side
		Over End	Over Side	Over End	Over Side	Over End	Over Side	Over End	Over Side			
ABOVE GROUND LEVEL	20' 0" (6.1 m)									23' 5" (7.1m)	4795 (2175)	4795 (2175)
	15' 0" (4.6 m)			9935 (4505)	9935 (4505)	6915 (3135)	6915 (3135)	5030 (2280)	5030 (2280)	25' 10" (7.9m)	4785 (2170)	4785 (2170)
	10' 0" (3.0 m)			11710 (5310)	11400 (5170)	7775 (3525)	7280 (3300)	5520 (2505)	5055 (2295)	27' 0" (8.2m)	4860 (2205)	4420 (2005)
	BOOM LEVEL 8' 8" (2.7 m)			12000 (5445)	11310 (5130)	7920 (3590)	7235 (3280)	5605 (2540)	5030 (2280)	27' 2" (8.3m)	4885 (2215)	4355 (1975)
	5' 0" (1.5 m)			12130 (5500)	11005 (4990)	8065 (3660)	7085 (3215)	5725 (2595)	4940 (2240)	27' 2" (8.3m)	4980 (2260)	4275 (1940)
AT GROUND LEVEL				10750 (4875)	10585 (4800)	7640 (3465)	6865 (3115)	5575 (2530)	4810 (2180)	26' 5" (8m)	5135 (2330)	4390 (1990)
BELOW GROUND LEVEL	5' 0" (1.5 m)	9650 (4375)	9650 (4375)	8590 (3895)	8590 (3895)	6700 (3040)	6670 (3025)			24' 5" (7.5m)	5285 (2395)	4860 (2205)
	10' 0" (3.0 m)	6325 (2870)	6325 (2870)	6565 (2980)	6565 (2980)	5595 (2540)	5595 (2540)			21' 1" (6.4m)	5360 (2430)	5360 (2430)
	15' 0" (4.6 m)	4175 (1895)	4175 (1895)	4940 (2240)	4940 (2240)					15' 2" (4.6m)	4940 (2240)	4940 (2240)

■ Shaded areas are stability rated based on machine with 0 lb. bucket.

The rated lift capacity is based on the machine being equipped with 8,850 lbs (4014 kg) counterweight, standard boom and no bucket.

The load point is located on the bucket pivot point, including load listed for maximum radius.

Do not attempt to lift or hold any load greater than these rated values at specified load radii and heights. The weight of slings and any auxiliary devices must be deducted from the rated load to determine the net load that may be lifted.

ATTENTION: All rated loads are based on the machine being stationary and level on a firm supporting surface. For safe working loads, the user must make allowance for his particular job conditions such as soft or uneven ground, out of level conditions, side loads, hazardous conditions, experience of personnel, etc. The operator and other personnel must be fully trained and understand the Operator's Manual and Safety Manuals furnished by the manufacturer before operating this machine. Rules for safe operation of the net load must be adhered to at all times.

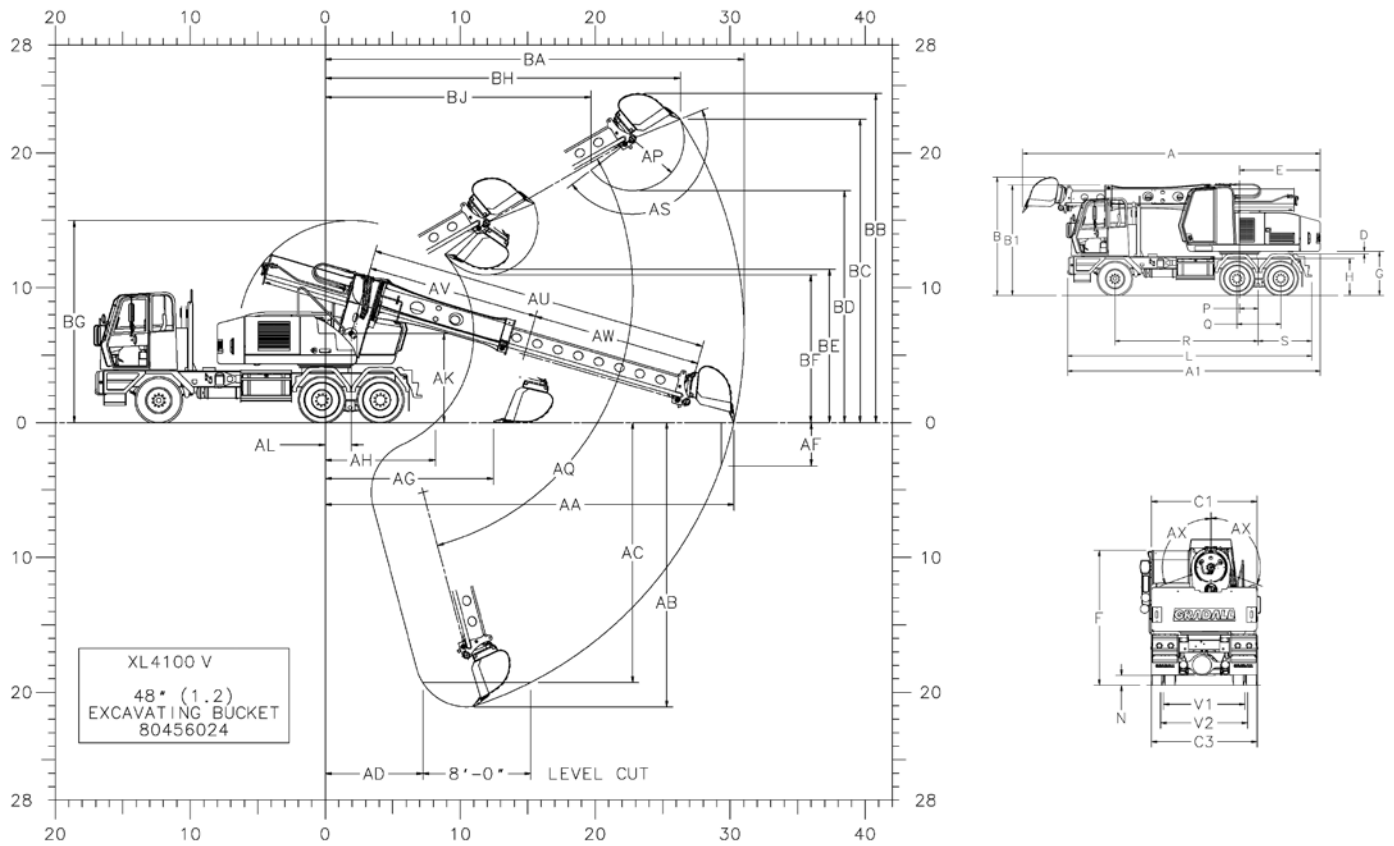

Dimensions

	6 x 4	6 x 6		6 x 4	6 x 6		
A	29' 6" (9.0m)	29' 6" (9.0m)	Overall length (boom in rack) w/ bucket	AG	12' 5" (3.8m)	12' 4" (3.8m)	Minimum level cut radius with bucket flat on ground line
A1	25' 1" (7.6m)	25' 1" (7.6m)	Overall length (boom in rack) w/o bucket	AH	8' 2" (2.5m)	7' 10" (2.4m)	Minimum radius at ground line
B	11' 9" (3.6m)	12' 0" (3.7m)	Overall height (boom in rack) w/ bucket	AK	6' 7" (2m)	6' 11" (2.1m)	Boom pivot to ground line
B1	10' 11" (3.3m)	11' 3" (3.4m)	Overall height (boom in rack) w/o bucket	AL	23" (584mm)	23" (584mm)	Boom pivot to axis of rotation
C1	8' 6" (2.6m)	8' 6" (2.6m)	Width of upperstructure	AP	46" (1.2m)	46" (1.2m)	Bucket tooth radius
C3	8' 6" (2.6m)	8' 6" (2.6m)	Width of undercarriage	AQ	30° Up & 75° Down	30° Up & 75° Down	Boom pivot angle
D	3" (76mm)	3" (76mm)	Minimum clearance, upperstructure to undercarriage	AS	165°	165°	Bucket pivot angle
E	8' 0" (2.4m)	8' 0" (2.4m)	Swing clearance, rear of upperstructure	AU	25' 3" (7.7m)	25' 3" (7.7m)	Maximum telescoping boom length (boom pivot to bucket pivot)
F	10' 10" (3.3m)	11' 1" (3.4m)	Top of cab to ground line	AV	12' 9" (3.9m)	12' 9" (3.9m)	Minimum telescoping boom length (boom pivot to bucket pivot)
G	52" (1.3m)	56" (1.4m)	Clearance, upperstructure to ground line	AW	12' 6" (3.8m)	12' 6" (3.8m)	Telescoping boom travel
H	44" (1.1m)	48" (1.2m)	Top of wheel mounted under carriage frame to ground line	AX	110°	110°	Bucket tilt angle (both sides of center)
L	24' 2" (7.4m)	24' 2" (7.4m)	Overall length of undercarriage	BA	31' 0" (9.5m)	31' 0" (9.5m)	Maximum radius of working equipment
N	10" (254mm)	10" (254mm)	Ground clearance (per SAE J1234)	BB	24' 5" (7.4m)	24' 8" (7.5m)	Maximum height of working equipment
P	22" (564mm)	22" (564mm)	Center of rear tandem to axis of rotation	BC	22' 6" (6.9m)	22' 10" (6.9m)	Maximum bucket tooth height
Q	52" (1.3m)	52" (1.3m)	Distance between centers of tandem axles	BD	17' 2" (5.2m)	17' 6" (5.3m)	Minimum clearance of bucket teeth, with bucket pivot at maximum height
R	14' 2" (4.3m)	14' 2" (4.3m)	Wheelbase	BE	11' 4" (3.5m)	11' 8" (3.6m)	Minimum clearance of fully curled bucket at maximum boom height
S	5' 4" (1.6m)	5' 4" (1.6m)	Center of rear axle to rear of frame (step)	BF	10' 11" (3.3m)	11' 3" (3.4m)	Minimum clearance of bucket teeth at maximum boom height
V1	6' 7" (2.0m)	6' 7" (2.0m)	Tread, rear axles (285/75R24.5 tires)	BG	15' 0" (4.6m)	15' 3" (4.7m)	Maximum height of working equipment with bucket below ground line
V2	7' 0" (2.1m)	7' 0" (2.1m)	Tread, front axle (385/65R22.5 tires)	BH	26' 4" (8.0m)	26' 4" (8.0m)	Radius of bucket teeth at maximum height
AA	30' 3" (9.2m)	30' 2" (9.2m)	Maximum radius at ground line (165° pivot)	BJ	19' 8" (6.0m)	19' 8" (6.0m)	Minimum radius of bucket teeth at maximum bucket pivot height
AB	20' 3" (6.2m)	19' 11" (6.1m)	Maximum digging depth				
AC	19' 3" (5.9m)	19' 0" (5.8m)	Maximum depth for 8' level cut				
AD	7' 3" (2.2m)	7' 3" (2.2m)	Minimum radius of 8' level cut at depth "AC"				
AF	3' 3" (1.0m)	3' 3" (1.0m)	Maximum depth of vertical wall which can be excavated				

Specifications subject to change without notice.
 Metric units are meters (m) unless noted.
 Machines shown may have optional equipment.

Weight

- Approximate working weight, fuel tank half full
 - 6 x 4: 49,684 lbs (22,539 kg)
 - 6 x 6: 50,925 lbs (23,099 kg)

Optional Equipment

- Vandalism protection kit including window covers
- Strobe light
- Block heater
- Tilt steering column
- Auxiliary hydraulics, with additional hosing and piping for hydraulic powered attachments. (Maximum pressure 4800 psi (33,095 kPa) Maximum flow 30 gpm (114 L/min))

Attachments

- Quick change and reversible buckets fabricated using steel plate with high strength, low alloy cutting edges and wear strips
- Standard attachments available for wide range of applications
- Capacities shown are in heaped cubic yard

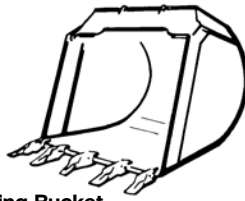

Excavating Bucket

		yd ³	m ³
8045-6020	24" (610mm) 603 lbs (274 kg)	3/8	0.31
8045-6021	30" (762mm) 660 lbs (300 kg)	1/2	0.41
8045-6022	36" (914mm) 741 lbs (336 kg)	5/8	0.54
8045-6023	42" (1,07m) 841 lbs (382 kg)	3/4	0.64
8045-6024	48" (1,22m) 957 lbs (434 kg)	1	0.76



Trenching Bucket

		yd ³	m ³
8065-6104	15" (381mm) 897 lbs (407 kg)	1/5	0.15
8065-6012	21" (533mm) 982 lbs (445 kg)	1/4	0.19

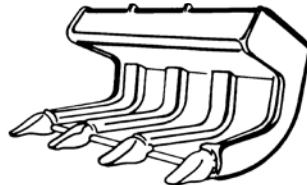

Pavement Removal Bucket

8065-6102	40" (1.0 m) 1262 lbs (573 kg)
-----------	----------------------------------

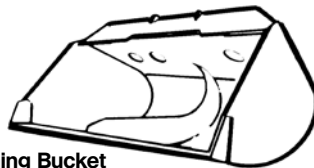

Ditching Bucket

		yd ³	m ³
8065-6007	60" (1,52m) 807 lbs (366 kg)	7/8	0.73
8065-6006	66" (1,68m) 892 lbs (405 kg)	1	0.76
8065-6002	72" (1,83m) 944 lbs (428 kg)	1 1/8	0.87



Dredging Bucket

		yd ³	m ³
8065-6013	72" (1,83m) 1114 lbs (505 kg)	1 1/8	0.87

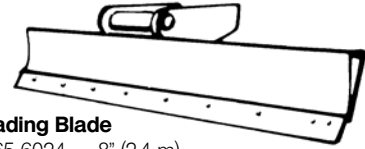

Grading Blade

8065-6024	8" (2.4 m) 630 lbs (285 kg)
-----------	--------------------------------

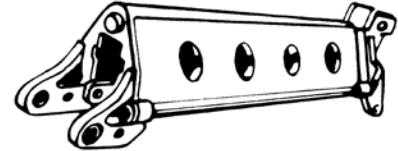

Boom Extension

8065-5028	4' (1.2 m) 1,090 lbs (495 kg)
8065-5029	6' (1.8 m) 1,250 lbs (560 kg)
8065-5030	8' (2.4 m) 1,389 lbs (631 kg)

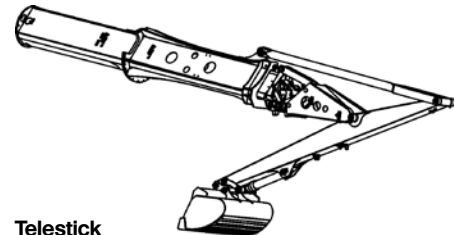

Telestick

8075-5045	3,600 lbs (1,633 kg)
-----------	----------------------

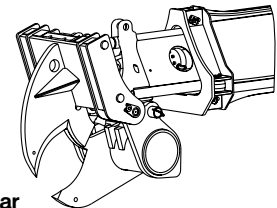

Tree Limb Shear

8045-5052	1,948 lbs (884 kg)
-----------	--------------------

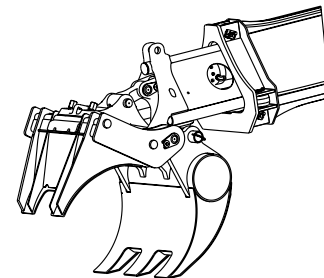

Fixed Thumb Grapple

8075-5023	1,574 lbs (714 kg)
-----------	--------------------

It is Gradall Policy to continually improve its products. Therefore designs, materials and specifications are subject to change without notice and without incurring any liability on units already sold. Units shown may have optional equipment.

GRADALL®

406 Mill Ave. SW, New Philadelphia, Ohio 44663
Phone: 800-445-4652 Fax: 330-339-8468
www.Gradall.com

Certified ISO 9001



Form No. 11816 7/18
Printed in USA