



912HM



HYDREMA





8 strategically placed working lights for optimum visibility. Optional Xenon lamps.

Spacious cab due to new profile angles and increased width between the profiles.



Easily accessible radio with CD and MP3 player.

12V and 24V sockets in the cab for tools etc.

All instrumentation is placed to the right of the operator for ease of use and access.

Ergo high sitting comfort seat with air option.



Multi adjustable steering wheel.

Automatic entry light activated by the door switches.



6.4" user-friendly TFT-display with integrated rear view camera.



Joysticks for easy control of body and gearshift.



Adjustable ergo arm rests for comfortable operation in all situations.



Electrically adjustable heated mirrors.

High quality, soft touch interior coating for ease of maintenance.

Fully adjustable climate control with optimally placed air nozzles.





912HM

It can't quite drive on water but the new Hydrema 912HM dump truck lets you to work in conditions and terrain that were previously out of bounds for normal dumptrucks.

With its 800 mm wide 30" wheels, high ground clearance and unique center pivot mounted precisely between the axles, this machine has some very unique characteristics. In soft terrain it will in many cases eliminate the need to lay out expensive trackway for more cost efficient and earthmoving.

The 912HM's low ground pressure - 7,6 PSI front/ 12,3 PSI rear - is ideal when it comes to installation and maintenance jobs on golf courses and similar soft conditions. We have a variety of tire options for different surfaces and like other Hydrema 912 models the HM is well known for being simple to operate and very safe and robust. Thus it is also very well suited as a rental machine.

Center pivot and roadholding qualities

The articulated pivot steering system and automatic weight transfer between the wheels is the key to the success of the Hydrema and one of the secrets behind the 912HM. The center pivot ensures that the wheels constantly turn both when rounding curves and turning around. This always gives you a single driving track and no crossways wheel movements. It is obvious when a Hydrema 912 has been at work, the only thing it leaves behind are its tire marks.... nothing else. With 800 mm twin tires in many cases the 912HM is the only machine that can enable you to complete a job quickly and efficiently and at a much lower cost than using alternative solutions such as crawler machines or having to put in haul roads.

Transmission

Designing for optimal pass ability and good handling off road the 912HM places high demands on its transmission. It is crucial that the gear shifts with no jerks or loss of tractive effort. This is guaranteed by the superior six-speed ZF ergopower transmission which shifts so smoothly it is hardly noticeable. An intelligent and thoroughly tested electronic system controls the gear shift and ensures fully automatic gear shifts in all conditions without the operator's intervention. When driving in extreme conditions it is important that the operator can focus on the driving and let the gear shifting take care of itself. The transmission may also be shifted manually in all gears to give the operator more control in adverse conditions.

Engine

The 912HM comes equipped with a Perkins TIER III common rail engine which offers high torque giving it the market's best power to weight ratio along with superior off road capabilities, high road speed and more power at lower RPM's. and fast transport driving. The machine also has reduced noise levels and excellent fuel economy.



Newly developed suspension

Driving in difficult conditions places great demands on the vehicle both in terms of handling the terrain and giving the operator a comfortable and efficient working day. The Hydrema 912HM comes fitted with a new front-axle suspension system as a standard feature. This system is an electro-hydraulic spring system with independent suspension cylinders, stabilizers and level control to the two front wheels. With its rapid regulation and long spring travel, this system provides an added level of comfort for this type of machine.

The operator will be less affected by vibrations over a long working day and experience much greater productivity, especially during long transport stages. The 912HM is not only more efficient but also gives the operator the best in cab working conditions.



Optimal operator comfort

The 912HM is also fitted with the newly developed D series cab, which sets a new standard for this type of vehicle. The cab gives the operator complete forward visibility, which is essential to safe driving on difficult terrain.

The Rops/Fops cab has a soft-touch interior and all the instrumentation is placed according to careful studies of the operator's everyday working situation and optimal working position. The steering wheel, seat and arm rests are adjustable to suit the individual operator. Visibility has been optimised by increasing the glazed area in the cab. The working environment is very important both for the operator and the machine's productivity over a long working day. The machine comes with a climate-control system with eight air nozzles as standard. Any cab vibrations are reduced by the use of liquid-filled engine suspension points and cab suspension. Cab safety is ensured by automatic entry and exit lighting, among other features.



User-friendly computer

The Hydrema 912HM has a Windows-based instrument display which provides the operator with a great deal of information via a 6.4" flat-screen monitor. The display also functions automatically as a monitor for the rear-view camera when the machine is put into reverse gear. The computer comes installed with rental menus, data collection and diagnostic tools.

The menu is very user-friendly even for inexperienced dumper-truck operators. It is possible to update the software and download data from the machine via a USB socket.

Dumper body

When the 912HM is used in extreme conditions, the payload is often wet and sticky. For this reason the dumper body was designed with round corners to ensure the material is removed easily during tipping. The Hydrema comes with a standard rear tip or special MultiTip which allows the operator to turn and tip the body anywhere within a 180 degree radius. Tipping brake, auto throttle control and auto body return are just some optional functions that automate much of the work to make the machine efficient and effective.



Dynamic design

We aim to make operating a Hydrema a good experience. Companies that invest in a Hydrema are also giving a signal to their customers that they work with the best products and the most modern designs available. We have employed industrial designers to attend to every detail of the machine's forms, materials and interior. The design details include the eight working lights in the roof with optional Xenon lamps, an LED backlight, a built-in toolbox, an asymmetrical instrument panel, and electrically adjustable heated side mirrors.



TECHNICAL DATA:

Chassis:

Articulated chassis in a heavy-duty robot-welded construction. 912HM has as standard Hydrema's new patent pending front axle suspension. Pivot with pendulum bar and double hydraulic stabilizer with the option of locking the oscillation movement. The pivot is fitted with large spherical pivot bearings. The fuel tank and hydraulic tank are integrated into the front chassis.

Oscillation 22°

Steering:

Hydrostatic Load Sensing pivot steering with 2 double acting cylinders. Priority valve and integrated emergency steering. Control cylinders with damping.

Max. steering angle ±35°

Axles:

Rigid axles are fixed. The front axle is sprung in strong joints. The axles have planetary reduction in the wheel hubs and separate oil chambers for the hubs. The front axle has automatic limited-slip differential lock and the rear axle has electro-hydraulically activated 100% differential lock.

Brakes:

Dual-circuit hydraulic servo system with immersed brake discs on each wheel. Self-adjusting and maintenance-free. Handbrake: Maintenance-free, »fail-safe« parking brake with electro-hydraulic activation of the wet disc brakes on the front axle.

Tires:

Standard twin tires: 600/60x30.5

Optional tires: 800/45x30.5

Engine:

Perkins E1104D-44TA TIER III engine. 4.4 l turbo diesel engine with air/air intercooler, 16 valves and common rail injection. 96 kW/131 hp at 2200 rpm. Max. torque 516 Nm at 1400 rpm. Latest engine technology which meets EPA TIER III requirements for exhaust emissions. 37 gal. fuel tank integrated into front chassis.

Transmission:

ZF WG115 6-speed fully automatic »ERGOPOWER« with full electronic control. Electronically-controlled pressure on each clutch ensures completely smooth gear shifts without any loss of tractive effort. (6 forward / 3 reverse). Constant 4WD.

Hydraulic system:

Hydraulic pump 22,2 gpm with priority for steering. Separate pump for brakes and stabilisers.

Dumper body:

Fabricated in robotically welded high tensile steel.

MultiTip (optional):

Compact slewing system with rapid dumping at the rear and to both sides. The slewing system is supported in a robust ball-bearing slewing ring. Pivotal movement takes place by means of 2 doubleacting cylinders. Tipping function by means of 2 singleacting telescopic cylinders.

Noise levels:

LwA: (outside) 104 db(A) 2000/14/EC

LpA: (inside) 73 db(A) ISO 6396

DIMENSIONS:

	Std. Tip:	MultiTip:	
Tires	800/45x30.5	800/45x30.5	
Total weight	40.080	41.094	lb
Unladen weight	18.033	19.047	lb
Load capacity	22.046	22.046	lb
Ground pressure, front/rear	7.6/12.3	7.9/12.6	Psi
A Track	6'9"	6'8"	ft.in.
B Total width	9'5"	9'5"	ft.in.
C Ground clearance	1'5"	1'5"	ft.in.
D Width, dump body	7'2"	7'2"	ft.in.
E Max. height	9'9"	9'9"	ft.in.
F Loading height	7'7"	8'2"	ft.in.
G Max. height for tipping	14'4"	15'2"	ft.in.
H Tipping clearance	4'0"	4'5"	ft.in.
I Overhang, rear	3'3"	3'1"	ft.in.
J Wheelbase	10'1"	10'1"	ft.in.
K Overall length	19'4"	19'1"	ft.in.
L Approach angle, front	37	37	°
M Departure angle, rear	74	74	°
N Tipping angle	75	67	°
R Overhang, front	6'0"	6'0"	ft.in.
V Overhang at tipping	--	1'0"	ft.in.
Capacity	7,3	7,3	yd ³
Turning radius	8,2	8,2	yd ³
Tipping time	6	8	sec.

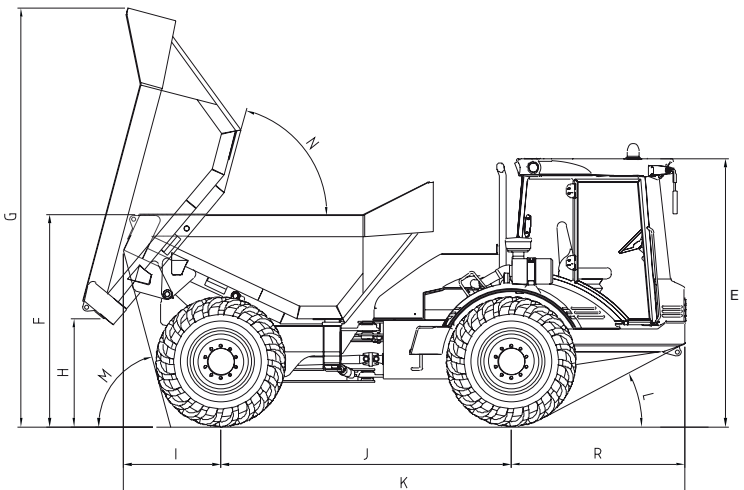
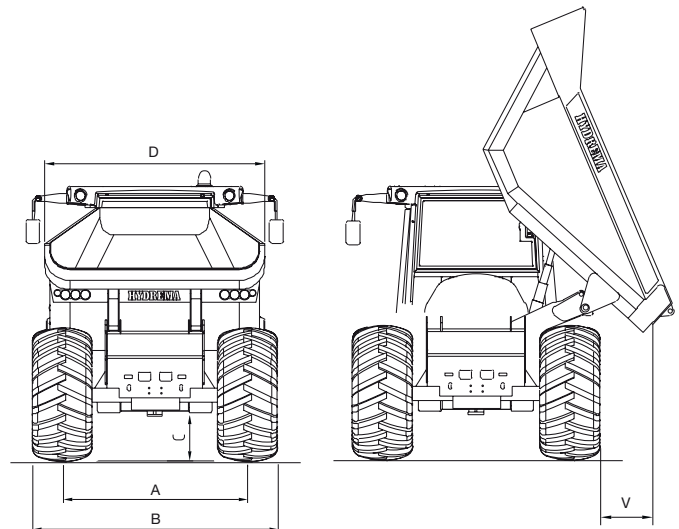

912HM

STANDARD EQUIPMENT:

- ◆ 600/60-30,5 TWIN tyres
- ◆ Waterproof sockets
- ◆ Friction differential in front
- ◆ 100% differential lock at the rear
- ◆ Cab with suspension
- ◆ Suspension on front axle with electronic level control
- ◆ Automatic air-conditioning
- ◆ Headrest
- ◆ Rotating beacon light
- ◆ Radio with CD/MP3
- ◆ Heated wing mirrors
- ◆ Seat heating
- ◆ Steering wheel knob
- ◆ Automatic driving lights
- ◆ 8 Mega Beam working lights
- ◆ 12V/24V plug in the cab
- ◆ Interval wiper front
- ◆ Sun blinds in front
- ◆ Portable lamp
- ◆ Red cabin light at night
- ◆ Automatic tipping speed adjustment
- ◆ Automatic tipping brake



OPTIONAL EQUIPMENT:

- ◆ Extra rotating beacon light
- ◆ Towing hook – fork type
- ◆ Tyres 800/45-30.5
- ◆ Bio-oil
- ◆ 180° MultiTip
- ◆ Automatic body return
- ◆ Pendulum lock
- ◆ Warning triangle
- ◆ Engine preheater
- ◆ Reinforced body
- ◆ Rear light protection
- ◆ Extended upper edge on body
- ◆ Air-suspended seat
- ◆ 3-point hitch
- ◆ Reverse camera
- ◆ Centralized lubrication system
- ◆ Electrically adjustable wing mirrors
- ◆ Xenon working lights
- ◆ GPS unit
- ◆ Customer graphics



HYDREMA US Inc.

1200 Northmeadow Parkway, Ste 180

Roswell, GA 30076

Phone: +1 404 614 1747

Fax: +1 800 254 9481



www.hydrema.com