



922HM



HYDRAMA





8 strategically placed working lights for optimum visibility. Optional Xenon lamps.

Spacious cab due to new profile angles and increased width between the profiles.



Easily accessible radio with CD and MP3 player.

12V and 24V sockets in the cab for tools etc.

All instrumentation is placed to the right of the operator for ease of use and access.

Ergo high comfort seat with air option.

Multi adjustable steering wheel.



6.4" user-friendly TFT-display. Integrated rear view camera. (option)

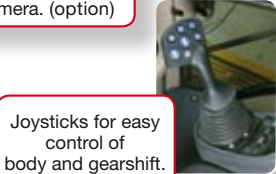

Joysticks for easy control of body and gearshift.

High quality, soft touch interior coating for ease of maintenance.

Adjustable ergo arm rests for comfortable operation in all situations.

Automatic entry light activated by the door switches.



Cooling box in the cab for storing food and beverages.

Electrically adjustable heated mirrors. (option)

Fully adjustable climate control with optimally placed air nozzles.



922HM

The Hydrema 922HM is the obvious choice for driving on soft terrain and in areas that demand the lowest possible ground pressure. Hydrema's three-axle dump truck, with its unique articulated pivot joint and bogies with a wide steering angle, offers superior tractive power, unmatched stability and the market's lowest unladen weight and performance/weight ratio, resulting in extremely low fuel consumption.

Low unladen weight and superb tractive power

The 922HM has an exceptionally low unladen weight and the best performance/weight ratio ever. It is designed as an articulated three-axle dump truck. The articulated chassis has pendulum bar and double hydraulic stabilizers in the pivot joint. These features ensure great stability during operation and when performing tipping operations, even when the dump truck is at maximum oscillating angle.

The 922HM breaks with traditional design principles for dump trucks in its class in a number of areas. All components are optimized precisely for the 922HM, a major contributory factor to the low unladen weight. Because the Hydrema 922HM is specially designed for driving on very soft surfaces with extra wide tires (800 mm), it is possible to work both early and late in the season.

Transmission

The tractive power on the six wheels stems from the automatic transmission with six forward and three reverse gears. The ultra-modern ZF transmission is equipped with 100% 'lock-up' in all gears,

giving direct drive which bypasses the converter, and thus minimal energy loss. The specially optimized software ensures the best possible connection between the engine and the transmission in any condition.

To equalize the speed differential between the dump truck's front and rear axles and ensure optimal accessibility, the transmission is equipped with a center differential with 100% differential lock. The transmission's shifting mechanism is electronically controlled via a joystick. You can choose between a fully automatic or manual tip-tronic gearshift. The advanced ergopower shift system ensures a very smooth gearshift, prevents wheel spin and gives the best possible traction in difficult conditions. Operation is quick and effective, as the same joystick is used for both the gear system and the tipping function.



Powerful hydraulic system

The hydraulic system in the 922HM consists of four hydraulic pumps. This solution was chosen to ensure that the machine's functions operate independently with the least possible energy loss. Thus two pumps with constant output function as: brakes, stabilizers in the center pivot, differential lock, front-axle suspension and tipping. The two other pumps with variable output take care of the pivot steering function and the emergency steering function. The separate pumps ensure completely independent control of the steering and tipping function, which means that the vehicle can be positioned as the tipping is started. On other models the steering is often restricted when the tipping function is used – not so with the Hydrema 922HM. The variable pump for the steering supplies a very large quantity of oil even at low engine RPM's, which ensures that the steering never feels sluggish. An energy-efficient and very comfortable solution.

Cab

Hydrema's new D-series cab gives the operator more room and improved visibility. Its high, central location and the steeply inclined, narrow hood gives the operator what is the best all-round visibility on the market: at the front of the vehicle, beside the engine and adjacent to the front wheels. The cab has a soft-touch interior and all the instrumentation is placed according to careful studies of the operator's everyday working situation and optimal working position. The steering wheel, seat and arm rests are adjustable to suit the individual operator.

The cab is equipped as standard with a robust climate-control system, which, along with the visco-elastic cab suspension points and the airsprung seat, gives the operator the best possible working conditions. The operator also has a refrigerated storage space.

Safety is optimal, the cab being fitted with easily accessible mount and dismount steps on both sides and entry and exit lighting when dark. Broad, electrically adjustable heated mirrors give the operator good rear visibility. The cab also has 12V and 24V electrical sockets for the operator's own equipment.



Computer-controlled instrument display

The Hydrema 922HM has a Windows-based instrument display with a 6.4" screen. The display gives the operator all the necessary information during operation, including text warnings if an abnormal operational situation arises. The computer is installed with data collection for service and instructions on daily maintenance for the operator.

Electronic suspension and level control – and 'genuine' bogie axles

The front axle is fitted with a new electronically controlled suspension and level control which provides great operator comfort at all speeds. The level control is separate on each side of the axle, which keeps the machine on a level when rounding corners. The front chassis can also be raised electronically by approximately 2", making progress easier in very soft terrain. The rear axle is a heavy-duty bogie axle with reduction gear. This is a very simple, maintenance-free and hard-wearing construction.

Hydrema has fitted the 922HM with a 'genuine' bogie axle because this construction has been shown to have better off-road performance than normal rigid axles. On the bogie axle each wheel has much greater freedom of movement than two single axles and thus better contact with the surface. Ground pressure is minimized as all six wheels stay in contact with the terrain. In addition, the bogie axles' individual movements guarantee greater operator comfort.



Brakes and bogie brake

The completely enclosed, oil-immersed operational brakes and handbrakes ensure safe braking, optimal cooling, and durability even in the toughest conditions. The brake system consists of two independent circuits and the handbrake is a spring-activated fail-safe brake. The vehicle has a standard, fully automatic bogie brake which works without the operator's intervention and ensures a very stable vehicle even during very steep downhill driving. The bogie brake is a combination of the engine brake and a newly developed hydraulic bogie brake which together provide superior braking ability.

Engine

In difficult terrain a dump truck needs lots of engine power and tractive power. Therefore from the beginning of the design process focus was put on achieving optimal off-road terrain qualities and extremely high traction. The engine is a six-cylinder Cummins turbo with intercooler, 24-valve technology, power boost function, and a fully electronic fuel injection system. The modern engine technology and variable speed fan provide very low fuel consumption and low noise levels.

Dump truck body

The body is made of high-tensile Hardox steel. The flat, sloping rear edge and a high tipping angle of 72° ensure effective tipping – material is discharged from the body quickly and easily. The powerful double-acting tipping cylinders have maximum protection on the underside of the body. The tipping hydraulics with servo automatically increases the engine revs when the tipping control lever is activated, thus achieving very fast tipping cycle times of just 7.5 sec. (up) and 5.5 sec. (down). The tipping cylinders are fitted with an end brake at each end to ensure that the body is lowered gently onto the chassis and the tipping speed is reduced just before the maximum tipping angle is reached. The auto body return function causes the body to descend automatically when the operator tips the joystick forward and lets go.

TECHNICAL DATA:

Chassis:

Articulated chassis with pendulum bar and double hydraulic stabilizers in the center pivot. The two stabilizers provide a high degree of stability both when driving and when carrying out dumping operations. The chassis is fabricated in high tensile steel in order to obtain the highest possible strength and the lowest possible unladen weight.

Oscillation: +/- 12°

Axles:

Front: rigid axle with electronically controlled suspension and level control. Individual level control on each side enables the vehicle to remain level when driving fast round corners. The front axle has a differential lock with 75% locking action. **Rear:** heavy-duty bogie axle with reduction gear at the differential and slow-moving gear in the bogie boxes. Simple and maintenance-free design.

Engine:

Cummins QSB 24 valve, 6.7 litre 6 cyl. tier III, with turbo and intercooler. 194 kW/264 hp at 2200 rpm. Power bulge: 201 kW/274 hp at 2000 rpm. Max. torque 990 Nm at 1300-1500 rpm. The engine is equipped with 24 valves and a fully electronically controlled common rail injection. The engine fan runs at variable revs according to cooling requirements. Latest engine technology which meets EPA tier III requirements for exhaust emission.

Transmission:

ZF ERGOPOWER 6 WG 210 automatic transmission with 6 forward gears and 3 reverse gears. The transmission is equipped with 100% "lock-up" in all gears, which electronically locks the connection between the engine and the transmission, and gives direct drive which bypasses the converter. A center differential is located in the transmission's output shaft in order to equalize the speed differential between the front and rear axle. The center differential has 100% differential lock. Electronic control of the transmission's shifting mechanism via a joystick (ZF Ergo 2), fully automatic or manual gearshift. Smooth gearshift which prevents wheel slip in difficult conditions.

Max. speed: forward: 31 mph / reverse: 19 mph

Max. tractive effort: 212 KN.

Steering:

The new servo activated hydrostatic steering results in great comfort, since impacts from the terrain are not transferred through to the steering wheel.

Separate variable pump for steering function.

Max. steering angle: +/- 38°

Brakes:

Full dual-circuit brake system with oil-immersed disc brakes on all 6 wheels. Fail-Safe parking brake on the front axle. Maintenance-free brakes. The brakes can be activated by a push button before dumping operations are commenced.

Retarder:

Exhaust brake and hydraulic retarder. Automatic controlled exhaust brake via engine. The hydraulic retarder can be engaged manually when needed.

Hydraulic system:

The hydraulic system consists of 4 independent hydraulic pumps:

Pump 1: 8,5 gpm. constant flow pump for brake, stabilizer, differential lock and suspension.

Pump 2: 40 gpm. variable flow pump for pivot steering.

Pump 3: 45 gpm. constant flow pump for tipping function.

Pump 4: 17 gpm. variable flow pump for emergency steering.

Electrical system:

Standard 24V el. system with 70 Amp. alternator.

Tires:

800/45-30.5 - Ground press., load.: 11,9 psi.

Dumptruck body:

Robot-welded dumptruck body in high tensile Hardox 450 steel without side ribs. The double action tipping cylinders are located under the body for maximum protection. As an option, the dumptruck body can be supplied with exhaust heat and an automatically functioning Tail Gate.

DIMENSIONS:

Total weight	79,610 lb
Unladen weight	35,540 lb
Load capacity	44,070 lb
Axle weights, front (unladen)	17,630 lb
Axle weights, centre (bogie)	8,600 lb
Axle weights, rear (bogie)	8,600 lb
Axle weights, front (loaded)	23,800 lb
Axle weights, centre (bogie)	27,550 lb
Axle weights, rear (bogie)	27,550 lb
B Total width: Tyres: 800/45-30.5	3,240 mm
C Ground clearance	19 "
D Width, body	9'0 "
E Max. height	11'6 "
Transport height	11'4 "
F Loading height	8'6 "
G Height raised body	20'8 "
H Tipping clearance	32 "
I Overhang, rear	55,5 "
J Wheel base, bogie	64,5 "
K Length	30'0 "
L Approach angle, front	25 °
M Approach angle, rear	67 °
N Tipping angle	72 °
O Wheel base	146 "
R Overhang, front	129 "
Body capacity, level	11,6 y ³
Body capacity, heaped	15,7 y ³
Tipping time, raise	7.5 sec.
Tipping time, lower	5.5 sec.
Turning radius, outer	27'9 "
Fuel tank	80 gal.
Hydraulic tank	53 gal.

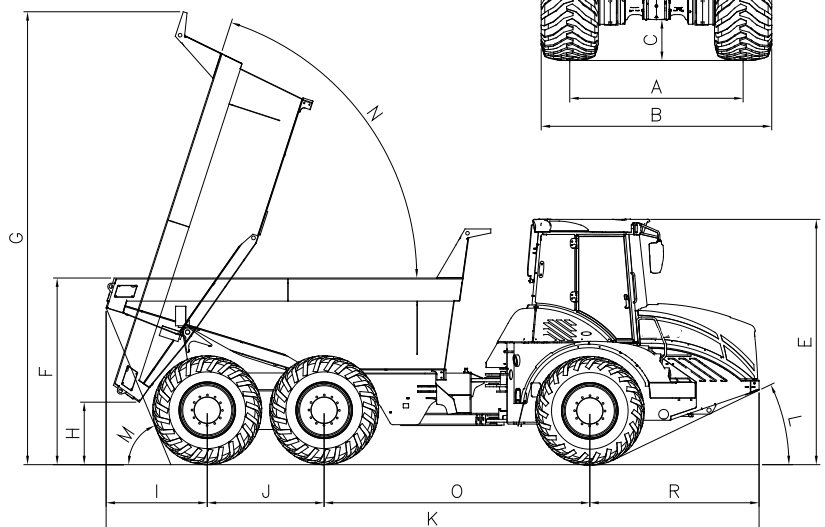
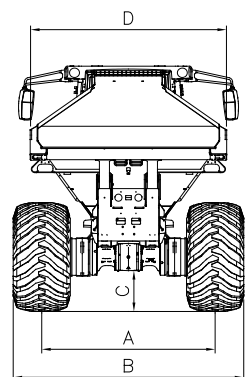
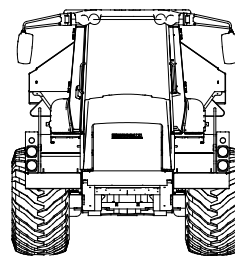

STANDARD EQUIPMENT:

Safety...

- ◆ Large heated side-view mirrors with swivel joint
- ◆ Rear lights integrated in dump body
- ◆ 8+2 working lights
- ◆ Non-slip steps for cab access and egress
- ◆ Acoustic reversing alarm
- ◆ Maintenance-free service and parking brake
- ◆ Rear view camera
- ◆ Hydraulic retarder

Cab/comfort...

- ◆ Climate Control system
- ◆ Air-suspended seat
- ◆ Visko-elastic cab suspension
- ◆ Bonnet with electric opening
- ◆ Front axle with suspension with automatic level control
- ◆ Multifunction joystick in right armrest
- ◆ Air filter and exhaust system located under hood
- ◆ 4 halogen front lights
- ◆ Computer-controlled instrument panel
- ◆ Two doors with easy access

Chassis...

- ◆ 12° oscillation in centre pivot
- ◆ Articulated with two hydraulic stabilisers in the pivot
- ◆ Weight transfer
- ◆ Hydraulic lines hidden/protected in centre pivot just above cardan shaft



OPTIONAL EQUIPMENT:

- ◆ Body exhaust heating kit
- ◆ Tail gate
- ◆ Rear lights protection
- ◆ Engine heater (220 v)
- ◆ Tyres:
800/45x30.5
20.5 R25 EM
- ◆ Electric fuel pump
- ◆ Automatic central lubrication system
- ◆ Xenon working lights
- ◆ Diesel heating - 9 kW



HYDREMA US Inc.

1200 Northmeadow Parkway, Ste 180

Roswell, GA 30076

Phone: +1 404 614 1747

Fax: +1 800 254 9481

hydrema@hydrema.com

