

KOMATSU®

HB215LC-1

HYBRID

HB215LC-1

NET HORSEPOWER

104 kW @ 2000 rpm
139 HP @ 2000 rpm

OPERATING WEIGHT

21,850 kg
48,175 lb

BUCKET CAPACITY

0.50–1.20 m³
0.66–1.57 yd³



PHOTOS MAY INCLUDE OPTIONAL EQUIPMENT

HB215LC-1

WALK-AROUND

Komatsu Technology Brings You the Opportunity to Make a Difference. Put Komatsu Innovation to Work for You.

The future of construction equipment has arrived!
Proven Hybrid technology from the leader
in Hydraulic excavators.

HB215LC-1



The FREE energy
harnessed by
the Hybrid reduces fuel
use and emissions.

Photos may include optional equipment.



NET HORSEPOWER

104 kW @ 2000 rpm
139 HP @ 2000 rpm

OPERATING WEIGHT

21,850 kg
48,175 lb

BUCKET CAPACITY

0.50–1.20 m³
0.66–1.57 yd³

Environmental Stewardship Now Means:

25% Average Fuel Savings

- Swing braking regenerates FREE energy
- FREE energy is used by swing motor and engine
- FREE or Regenerated energy use saves fuel

Emissions Reduction

- Fuel savings equal emissions reductions
- CO₂ and green house gas emissions are reduced
- Harmful emissions such as Nitrous Oxides (NOx) are reduced

Friendly to the Environment

- Low emissions engine
- Eco-drains for fluids
- Excessive idle caution

Quiet Machine

- Low operation noise
- Reduced noise levels for urban and night work
- Low cab noise for operator comfort



The Komatsu Advantage:

Powerful Performance

- Hybrid power assist
- Responsive work equipment
- Strong electric swing

Peace of Mind

- Hybrid power train is covered by a 5 year / 7,000 hour warranty

Proven Technology

- Over one million operating hours

KOMTRAX®

- Wireless remote monitoring

Reduce your carbon footprint while saving fuel!



Komatsu Innovation Leads the new Generation of Hydraulic Excavators.

Reliable and Durable Hybrid Components Developed and Manufactured by Komatsu

1 Electric Swing Motor

An electric swing motor is used in place of the hydraulic swing motor and is designed to recover energy during swing braking. Energy is sent to the ultra-capacitor for storage.



2 Ultra-capacitor Assembly

The ultra-capacitor assembly includes an inverter that switches the AC electricity from the generator motor and swing motor into DC electricity for storage in the capacitor. Since capacitors require migration of electrons and ions for charging and discharging, they can transfer power much faster than batteries, which use chemical reactions to produce electricity.



CAPACITOR CHARACTERISTICS

The capacitor is charged and discharged by the migration of electrons and ions. A large amount of energy can be recovered quickly and efficiently.

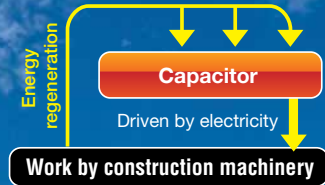

Regeneration energy captured by swing motor & sent to ultra capacitor for storage.

1 Electric Swing Motor

3 Generator Motor

2 Ultra-capacitor

Stored energy from the capacitor provides power up assist energy to the engine

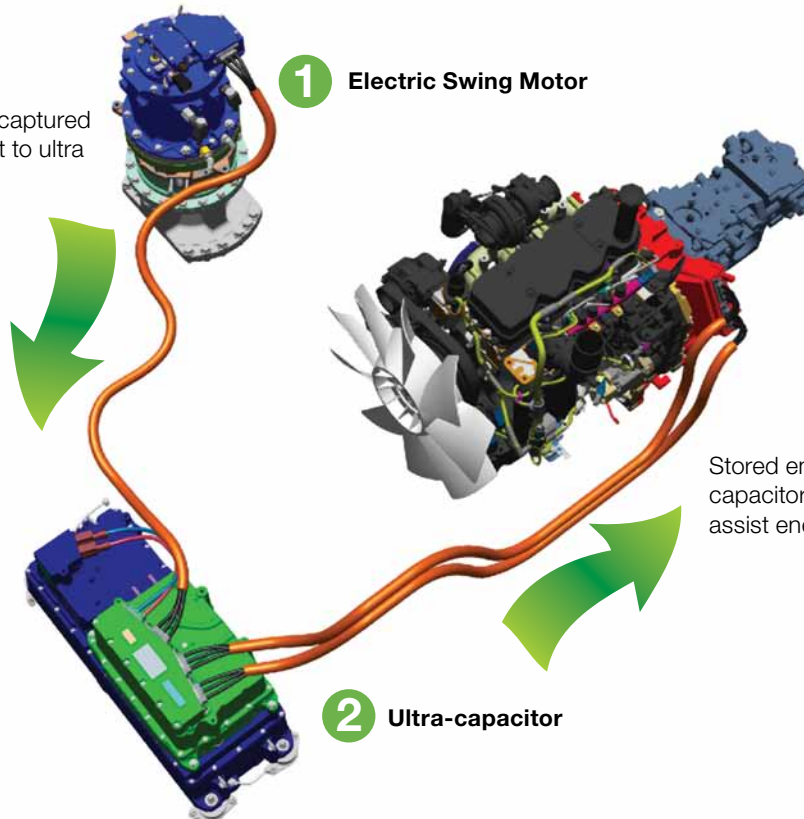

3 Generator Motor

The generator motor is positioned between the engine and hydraulic pumps.

- The generator produces electric power to charge the capacitor as needed.
- The generator motor uses electricity from the capacitor to provide power up engine assistance to the engine.

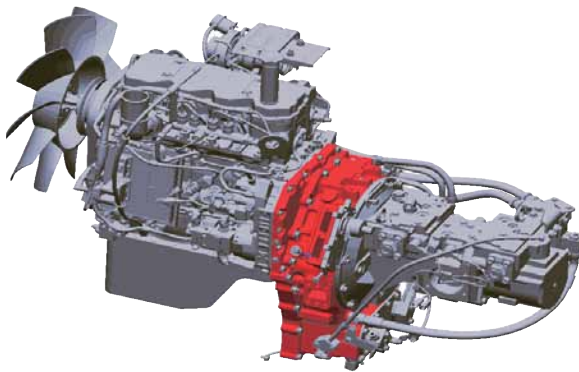

Captured energy provides up to
60 additional HP

Easy-to-understand Hybrid Operation Monitor Screen

Energy Management Screen

The operation status of the hybrid system is displayed on the screen as energy flows, which include capacitor charging/discharging and engine assist by the generator/motor.



Hybrid System Temperature Gauge

The hybrid system temperature gauge appears on the main screen along with the coolant and hydraulic temperature gauges. It displays the hybrid system temperature and allows the operator to see the hybrid temperature status at a glance.



KOMATSU HYBRID SYSTEM

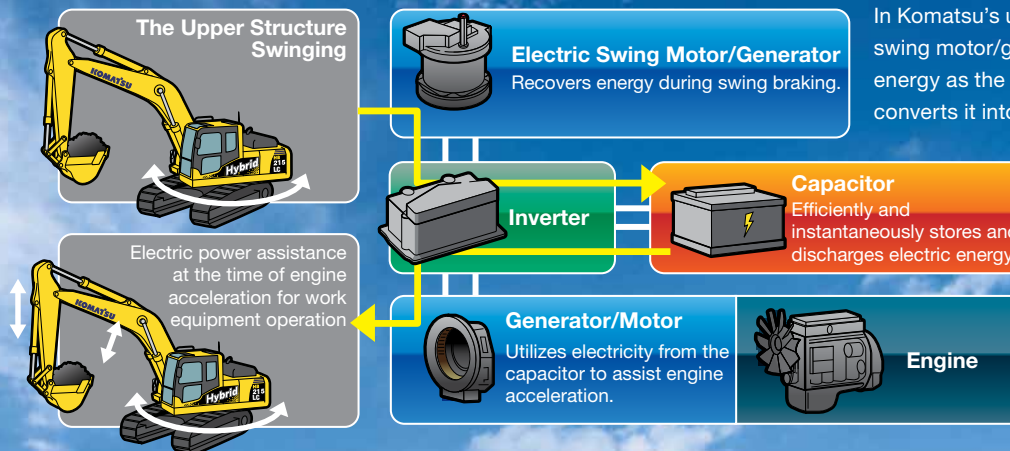

In Komatsu's unique hybrid system, the electric swing motor/generator captures and regenerates energy as the upper structure slows down and converts it into electric energy. The regenerated energy is stored in the capacitor and used by the generator/motor to assist the engine when it needs to accelerate. Thus, the hybrid system reduces fuel consumption significantly. Most components of the system are developed and manufactured by Komatsu.

*: Except capacitor cells



PERFORMANCE AND ECO-FRIENDLY

Komatsu Hybrid Technology Reduces Fuel Consumption and Emissions and Provides Better Performance.

Energy-saving Operation for Reduced CO₂ Emissions

Low Emission Engine

Komatsu SAA4D107E-1-A engine is EPA Tier 3 and EU Stage 3A emissions certified, without sacrificing power or machine productivity.



Low Speed Matching

Low Speed Matching is a highly efficient matching technique between the engine and hydraulic system.

- It uses highly advanced control logic to match hydraulic pump operation at the most efficient engine speed.
- Low speed matching increases engine speed from the 700 rpm ultra-low idle as the hydraulic demand increases.
- The low speed matching system is complemented by the Hybrid power up assistance provided by the generator motor using energy from the ultra capacitor.
- Fuel consumption is therefore reduced due to the available electrical power – up to 60 additional HP is provided by the Hybrid system depending on demand.

Working Mode Selection

P Mode – Power or work priority mode has improved fuel consumption, while maintaining maximum production.

E Mode – Economy or fuel priority mode reduces fuel consumption, but maintains the P mode-like work equipment speed for light duty work.

L Mode – Lifting mode increases hydraulic pressure.

B Mode – Breaker mode with optimum engine rpm, hydraulic flow, 1-way.

ATT Mode – Attachment mode with optimum engine rpm, hydraulic flow, 2-way.



TOTAL VEHICLE CONTROL & HYBRID SYSTEM

In addition to the engine, hydraulic components, main valve and electronic components that control them, the hybrid system components such as the generator/motor, swing electric motor/generator, inverter and capacitor are also developed and manufactured by Komatsu. They are neatly arranged on the machine. Controlling the inverter enables the optimum operation of the generator/motor, electric swing motor/generator and engine according to the work at hand, allowing the machine to demonstrate its potential fully while reducing fuel consumption significantly. The machine monitor displays the bar chart that indicates the average fuel consumption in the previous 5 minutes. The Eco-gauge shows the work load to assist the operator to perform energy-saving operations. Hybrid HB215LC-1 reduces CO₂ emissions making them environmentally-friendly machines.

Fuel consumption

25% reduced

Compared to PC200LC-8 according to Komatsu test standards. The value can change based on the work.

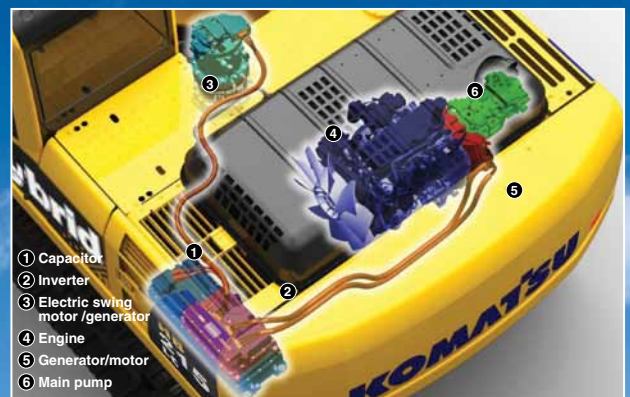

OPERATOR COMFORT

Comfortable Operating Environment for the operator.
The quiet and spacious ROPS cab allows the operator to operate the machine comfortably and efficiently.



Low Cab Noise

The newly-designed cab is highly rigid and has excellent sound absorption ability. By improving noise source reduction and using a low noise engine, hydraulic equipment, and air conditioner, this machine is able to generate low noise levels similar to that of a modern automobile. Wide and spacious cab provides ample leg room, allowing an operator with a large body frame to take a comfortable operational posture.

Low Vibration with Viscous Cab Mounts

The HB215LC-1 uses viscous mounts for the cab that incorporates a longer stroke and the addition of a spring. The cab damper mounting combined with a high rigidity deck reduces vibration at the operator's seat.

Automatic Air Conditioner

The automatic air conditioner allows the operator to easily and precisely set the cab atmosphere using the large LCD color monitor panel. The bi-level control function improves air flow and keeps the inside of the cab comfortable throughout the year.

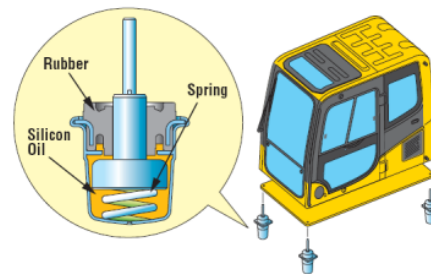

Pressurized Cab

The air conditioner, air filter, and a higher internal cab air pressure minimize the amount of external dust that enters the cab.

12 volt Outlet

12 volt outlet is standard equipment.



HB215LC-1 ROPS Cab Design

The HB215LC-1 is equipped with an ISO compliant cab as standard equipment. The cab gains strength from the reinforced pipe structured framework, providing high impact absorbency and resistance. The cab also meets OPG top guard level 1 requirements.



INFORMATION CONTROL TECHNOLOGY

Easy to Locate Information and Simple to Read Screens
Keep the Operator Informed of Machine Status.

Large Multi-lingual LCD Monitor

A large, user-friendly color monitor enables accurate and smooth work. Improved screen visibility is achieved by the use of TFT liquid crystal display that can easily be read at various angles and lighting conditions. The switches are simple and easy to operate. Industry first function keys facilitate multi-function operations. Displays data in 12 languages to globally support operators around the world.



Indicators

- | | |
|------------------------------------|------------------------------------|
| 1 Auto-decelerator | 6 Hybrid system temperature gauge |
| 2 Working mode | 7 Fuel gauge |
| 3 Travel speed | 8 Eco-gauge |
| 4 Engine coolant temperature gauge | 9 Average fuel consumption monitor |
| 5 Hydraulic oil temperature gauge | 10 Function switches menu |

Basic operation switches

- | | |
|-------------------------|---------------------|
| 1 Auto-decelerator | 4 Buzzer cancel |
| 2 Working mode selector | 5 Wiper |
| 3 Traveling selector | 6 Windshield washer |

Operator Assistance Function for Effective and Efficient Operation

Fuel Consumption and Energy Flow Screens

The operator can check recent fuel consumption rates and the energy flow among engine and hybrid components on the machine monitor at any time.

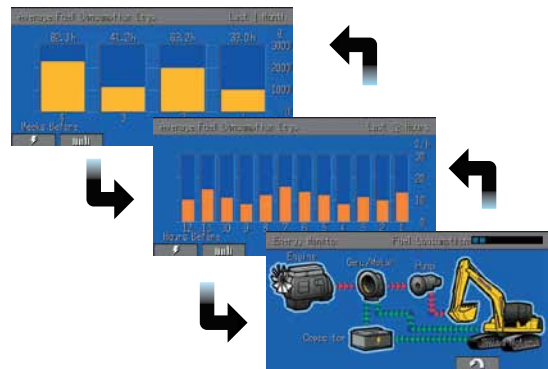

Rear View Monitoring System

The machine is equipped with a rear view camera, allowing the operator to see the area behind the machine on the large LCD monitor screen.



Password Protection for Engine Start (Immobilizer)

The engine cannot be started unless the registered password is entered correctly.



KOMTRAX® Message

KOMTRAX® communication function allows you to get and read messages from your Komatsu dealer on the machine monitor.

KOMTRAX EQUIPMENT WORKING ENVIRONMENT MONITORING



KOMTRAX is Komatsu's remote equipment monitoring and management system. KOMTRAX gathers critical machine and operation information and provides it in a user-friendly format so that you can make well-informed decisions. KOMTRAX gives you more control of your equipment and better control of your business!

KOMTRAX comes standard on all new Komatsu machines with complimentary manufacturer communications services throughout the entire ownership period. It is a powerful tool and makes Komatsu machines an even better purchase!

Fleet Optimization

KOMTRAX tells you how your machines and operators are performing. KOMTRAX provides:

- Fuel consumption data and trends, by unit or fleet
- Machine fuel level
- Machine utilization
- Actual working hours/Machine idle hours
- Attachment usage hours
- Machine travel hours
- Machine load analysis
- Operating mode ratios

Location and Asset Management

KOMTRAX tells you where your machines are and can help prevent unauthorized use. KOMTRAX provides:

- GPS location/Operation maps
- Out-of-area and movement alert with location and time
- Engine, nighttime, and calendar lock

Maintenance Management

KOMTRAX monitors the health of your machines and provides critical information so that you, and your distributor, can take proactive maintenance measures and reduce downtime. KOMTRAX provides:

- Service Meter Reading (SMR)
- Cautions/Abnormality codes
- Maintenance replacement notifications

Easy and Flexible Access to Information

With KOMTRAX, information about your machines is through a convenient, internet-based portal. KOMTRAX provides:

- A user-friendly KOMTRAX website that provides customized access to your machine information
- E-mail and text alerts
- Web dial-up service
- Monthly fleet summary reports

For more information, including terms and conditions of the manufacturer complimentary KOMTRAX communication service, ask your distributor, pick up a KOMTRAX brochure, or go to www.komatsuamerica.com/komtrax.



For construction and compact equipment.



For production and mining class machines.



Simplified Check and Maintenance Work for Keeping the Machine at its Best.

Excellent Maintainability for Reduced Check and Maintenance Time

Side-by-side Cooling

Since radiator, after-cooler and oil cooler are arranged in parallel, they are easy to clean, remove and install. Radiator, aftercooler, and oil cooler are made of aluminum, have high cooling efficiency, and are easily recycled.



Air Conditioner Filter

The air conditioner filter is removed and installed without the use of tools facilitating filter maintenance.



Gas Assisted Engine Hood Damper Cylinders



Equipped with the Engine Eco-drain Valve as Standard.



Swing Motor Oil Level Check

1. Swing Motor Oil Fill
2. Swing Motor Oil Check



Hybrid Coolant Sight Gauge*

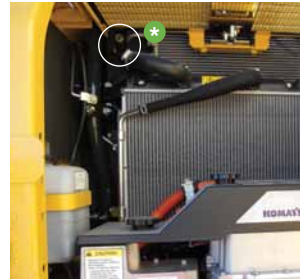

1. Generator Motor Oil Level Check
2. Generator Motor Oil Level Fill
3. Engine Oil Filter
4. Fuel Pre-filter
5. Generator Motor Oil Filter
6. Main Fuel Filter

Equipped with a Fuel Pre-filter-

with water separator and built in priming pump. Removes water and contaminants in the fuel to prevent fuel problems.

High Efficiency Fuel Filter

Fuel system reliability is even better with high efficiency fuel filter.

Easy Access to Engine Oil Filter and Fuel Drain Valve

Generator Motor Oil Level Check

ACCURATE and PROMPT DIAGNOSIS

Thanks to **EMMS**
(Equipment Management Monitoring System)

EMMS
Equipment Management Monitoring System

Monitor Function

Controller monitors engine oil level, coolant temperature, battery charge and air clogging, etc. If controller finds any abnormality, it is displayed on the LCD.



Maintenance Function

Monitor informs replacement time of oil and filters on LCD when the replacement interval is reached.



Trouble Data Memory Function

Monitor stores abnormalities for effective troubleshooting.

Long-life Oil, Filter

Uses high-performance filtering materials and long-life oil*. Extends the oil and filter replacement interval.



Hydraulic oil filter
(Eco-white element)

Engine oil & Engine oil filter	every 500 hours
Hydraulic oil	every 5000 hours
Hydraulic oil filter	every 1000 hours
Electric swing motor oil	every 1000 hours
Generator motor oil, filter cleaning	every 1000 hours

*See Operation and Maintenance Manual for oil specifications.

Hybrid



Photo may include optional equipment.



KOMATSU PARTS & SERVICE SUPPORT



Komatsu is an industry leader in building reliable and technologically advanced machines. It is only fitting that we would provide superior Product Support. Komatsu and its distributors are focused on providing their customers unparalleled Product Support throughout the entire lifecycle of the machine. It's called Komatsu CARE.



Komatsu CARE – Extended Coverage

Komatsu equipment is built to withstand harsh operating environments, but our Extended Coverage can provide further peace of mind by protecting customers from unplanned expenses and impacts in cash flow. Purchasing Komatsu CARE's Extended Coverage locks-in the cost of covered parts and labor for the extended warranty period and helps to turn these variable expenses into a fixed cost.

- No Stop Loss or Loss Limits imposed, regardless of the coverage type or repair expense
- Any combination of months and hours out to five years and 10,000 engine hours – KOWA kits included
- Coverage premium can be rolled into the machine financing at time of sale or purchased any time before the expiration of the machine's standard warranty
- Coverage is fully transferable and honored by all Komatsu distributors throughout the U.S. and Canada

Komatsu Parts Support

Because downtime can be costly, Komatsu maintains a strategic distribution network throughout the U.S. and Canada, to ensure superior parts availability and to keep your Komatsu machine up and running.

- Komatsu America has nine Parts Distribution Centers strategically located throughout the U.S. and Canada
- Komatsu America's Parts distribution network is accessible 24/7/365 to fulfill your parts needs
- Komatsu has a distributor network of over 325 locations across the U.S. and Canada
- Online parts ordering available through Komatsu eParts, 24/7/365. (See distributor for details)
- Komatsu offers a full line of factory Remanufactured products with same-as-new warranties at a significant cost reduction:
 1. Complete Engine Assemblies
 2. Transmissions
 3. Torque Converters
 4. Hydraulic components
 5. Starters, Alternators, turbochargers and circuit boards

Komatsu Oil and Wear Analysis (KOWA)

The KOWA program uses independent laboratories across the United States to determine how your machine is performing based on a small sample of oil or other fluid. Just like a doctor will take a blood test to check on your personal health, KOWA allows you to check how your equipment is performing. Used with PM Clinic and PM Tune Up, KOWA is one of your best tools for proactively maintaining your Komatsu equipment and maximizing its availability and performance.

KOWA detects fuel dilution and coolant leaks, identifies contaminants, and measures wear-metals. Your distributor will help you interpret this information so you can identify potential problems and head them off before they lead to major repairs.

For more information of all of the manufacturer sponsored programs mentioned in this brochure, including terms and conditions of the individual programs, please speak with your distributor or go to www.komatsuamerica.com

SPECIFICATIONS



ENGINE

Model.....Komatsu SAA4D107E-1-A
 Type.....Water-cooled, 4-cycle, direct injection
 Aspiration..... Turbocharged, aftercooled
 Number of cylinders..... 4
 Bore..... 107 mm **4.21"**
 Stroke..... 124 mm **4.88"**
 Piston displacement..... 4.46 ltr **272 in³**
 Horsepower:
 SAE J1995..... Gross 110 kW **148 HP**
 ISO 9249 / SAE J1349..... Net 104 kW **139 HP**
 Rated rpm..... 2000 rpm

Fan drive method for radiator cooling..... Mechanical
 Governor..... All-speed control, electronic
 EPA Tier 3 and EU Stage 3A emission certified



HYDRAULIC SYSTEM

HydraMind (Hydraulic Mechanical Intelligence New Design) system, closed-center system with load sensing valves and pressure compensated valves.

Number of selectable working modes..... 5

Main pump:

Type..... Variable displacement piston type
 Pumps for..... Boom, arm, bucket and travel circuits
 Maximum flow..... 439 ltr/min **116 U.S. gal/min**
 Supply for control circuit..... Self-reducing valve

Hydraulic motors:

Travel..... 2 x axial piston motor with parking brake

Relief valve setting:

Implement circuits..... 37.3 MPa 380 kgf/cm² **5,400 psi**
 Travel circuit..... 37.3 MPa 380 kgf/cm² **5,400 psi**
 Pilot circuit..... 3.2 MPa 33 kgf/cm² **470 psi**

Hydraulic cylinders:

(Number of cylinders – bore x stroke x rod diameter)

Boom..... 2–120 mm x 1334 mm x 85 mm **4.7" x 52.5" x 3.3"**
 Arm..... 1–135 mm x 1490 mm x 95 mm **5.3" x 58.7" x 3.7"**
 Bucket..... for 2.93 m **9'7"**
 Arm..... 1–115 mm x 1120 mm x 80 mm **4.5" x 44.1" x 3.2"**



SWING SYSTEM

Drive method..... Electric drive
 Swing reduction..... Planetary gear
 Swing circle lubrication..... Grease-bathed
 Service brake..... Electric brake
 Holding brake/Swing lock..... Mechanical disc brake
 Swing speed..... 12.4 rpm
 Swing torque..... 7040 kg•m **50,920 ft. lbs.**



DRIVES AND BRAKES

Steering control..... Two levers with pedals
 Drive method..... Hydrostatic
 Maximum drawbar pull..... 178 kN 18200 kg **40,120 lb**
 Gradeability..... 70%, 35°
 Maximum travel speed: High..... 5.5 km/h **3.4 mph**
 (Auto-Shift) Mid..... 4.1 km/h **2.5 mph**
 (Auto-Shift) Low..... 3.0 km/h **1.9 mph**
 Service brake..... Hydraulic lock
 Parking brake..... Mechanical disc brake



UNDERCARRIAGE

Center frame..... X-frame
 Track frame..... Box-section
 Seal of track..... Sealed track
 Track adjuster..... Hydraulic
 Number of shoes (each side)..... 49
 Number of carrier rollers..... 2 each side
 Number of track rollers (each side)..... 9



COOLANT AND LUBRICANT CAPACITY (REFILLING)

Fuel tank..... 400 ltr **105.7 U.S. gal**
 Coolant (Engine)..... 17.3 ltr **4.6 U.S. gal**
 (Hybrid)..... 5.2 ltr **1.4 U.S. gal**
 Final drive, each side..... 3.3 ltr **0.9 U.S. gal**
 Swing drive..... 7.1 ltr **1.9 U.S. gal**
 Swing motor..... 1.6 ltr **0.4 U.S. gal**
 Generator motor..... 6.0 ltr **1.6 U.S. gal**
 Hydraulic tank..... 135 ltr **35.7 U.S. gal**



OPERATING WEIGHT (APPROXIMATE)

Operating weight including 5700 mm **18'8"** one-piece boom, 2925 mm **9'7"** arm, SAE heaped 0.80 m³ **1.05 yd³** backhoe bucket, rated capacity of lubricants, coolant, full fuel tank, operator, and standard equipment.

Shoes	HB215LC-1	
	Operating Weight	Ground Pressure
800 mm 31.5"	21850 kg 48,175 lb	33.9 kPa 0.35 kgf/cm ² 4.9 psi



DIMENSIONS

Item	Value	Value
Arm Length	2925 mm	9'7"
A Overall length	9425 mm	30'11"
B Length on ground (transport)	5000 mm	16'5"
C Overall height (to top of boom)	2970 mm	9'9"
D Overall width	3180 mm	10'5"
E Overall height (to top of cab)	3040 mm	10'0"
F Ground clearance, counterweight	1085 mm	3'7"
G Ground clearance (minimum)	440 mm	1'5"
H Tail swing radius	2750 mm	9'0"
I Track length on ground	3655 mm	12'0"
J Track length	4450 mm	14'7"
K Track gauge	2380 mm	7'10"
L Width of crawler	3180 mm	10'5"
M Shoe width	800 mm	31.5"
N Grouser height	26 mm	1.0"
O Machine cab height	2095 mm	6'10"
P Machine cab width	2710 mm	8'11"
Q Distance, swing center to rear end	2710 mm	8'11"

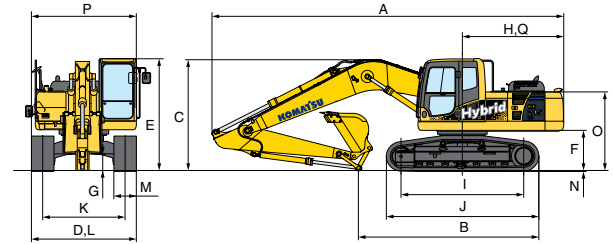

LIFTING CAPACITY WITH LIFTING MODE

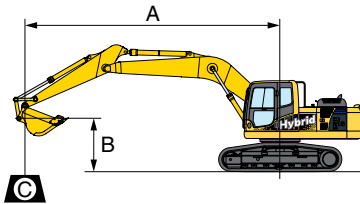

- A: Reach from swing center
- B: Bucket hook height
- C: Lifting capacity
- Cf: Rating over front
- Cs: Rating over side
- ☉: Rating at maximum reach

Conditions:
 5700 mm **18'8"** one-piece boom
 0.8 m³ **1.05 yd³** SAE heaped bucket

 Shoe width:
 HB215LC-1 700 mm **28"** triple grouser

HB215LC-1	Arm 2925 mm 9'7" Bucket 0.8 m ³ yd ³ SAE heaped						Shoe: 700 mm 28" triple grouser				Unit: kg/lb	
	1.5 m 5'		3.0 m 10'		4.6 m 15'		6.1 m 20'		7.6 m 25'		☉ MAX	
A \ B	Cf	Cs	Cf	Cs	Cf	Cs	Cf	Cs	Cf	Cs	Cf	Cs
6.1 m							*3550	*3550			*2950	*2950
25'							*7,850	*7,850			*6,500	*6,500
6.1 m							*5350	*4650			*2800	*2800
20'							*11,800	*10,350			*6,150	*6,100
4.6 m					*6750	*6750	*6150	4500	*4500	3050	*2800	2700
15'					*14,900	*14,900	*13,550	10,000	*10,050	6,700	*6,200	5,950
3.0 m			*14050	*13200	*9050	6750	*7000	4250	4800	2950	*2950	2400
10'			*31,000	*29,150	*20,000	14,950	*15,500	9,450	10,650	6,500	*6,550	5,350
1.5 m			*7350	*7350	10850	6250	6700	4000	4700	2800	*3250	2300
5'			*16,200	*16,200	24,000	13,750	14,850	8,900	10,350	6,200	*7,200	5,100
0 m			*8250	*8250	10450	5900	6500	3850	4600	2700	*3750	2350
0'			*18,250	*18,250	23,100	13,000	14,350	8,450	10,100	6,000	*8,350	5,200
-1.5 m	*7250	*7250	*11650	11350	10300	5750	6400	3750	4550	2650	4350	2550
-5'	*16,000	*16,000	*25,750	25,000	22,800	12,750	14,150	8,250	10,000	5,900	9,600	5,650
-3.0 m	*11100	*11100	*16750	11500	10350	5800	6400	3750			5200	3050
-10'	*24,450	*24,450	*37,000	25,400	22,900	12,800	14,200	8,300			11,500	6,800
-4.6 m			*15400	11900	10500	5900					7550	4450
-15'			*34,000	26,250	23,150	13,050					16,700	9,800

*Load is limited by hydraulic capacity rather than tipping. Ratings are based on ISO standard No. 10567. Rated loads do not exceed 87% of hydraulic lift capacity or 75% of tipping load.

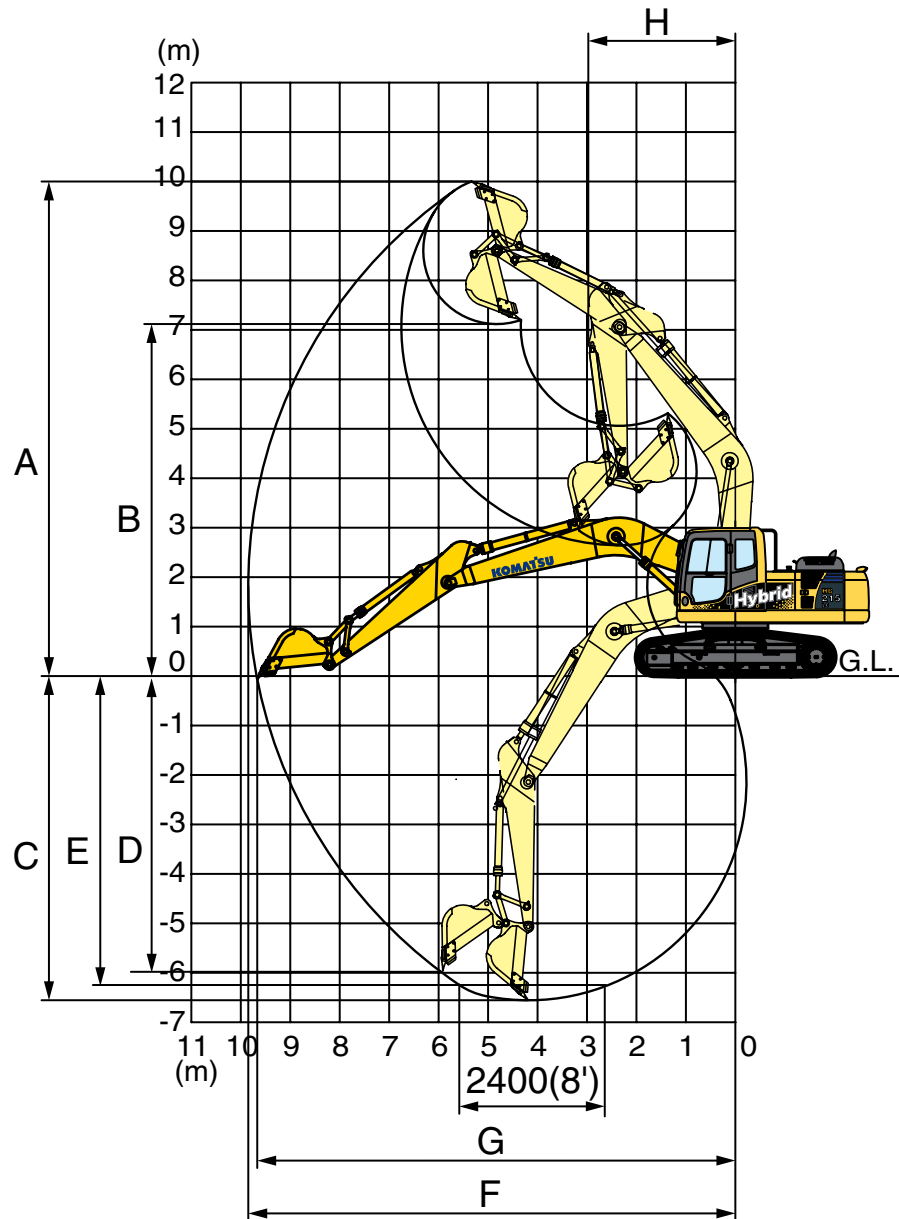

WORKING RANGE

	Arm	2925 mm	9'7"
A	Maximum digging height	10000 mm	32'10"
B	Maximum dumping height	7110 mm	23'4"
C	Maximum digging depth	6620 mm	21'9"
D	Maximum vertical wall digging depth	5980 mm	19'7"
E	Maximum digging depth of cut for 8' level	6370 mm	20'11"
F	Maximum digging reach	9875 mm	32'5"
G	Maximum digging reach at ground level	9700 mm	31'10"
H	Minimum swing radius	3040 mm	10'0"
SAE Rating	Bucket digging force at power max.	138 kN 14100 kgf	31,080 lb
	Arm crowd force at power max.	101 kN 10300 kgf	22,710 lb
ISO Rating	Bucket digging force at power max.	149 kN 15200 kgf	33,510 lb
	Arm crowd force at power max.	108 kN 11000 kgf	24,250 lb



BACKHOE BUCKET, ARM, AND BOOM COMBINATION

Bucket Type	Bucket				Arms		
	Capacity	OLW	Weight	2925 mm 9'7"			
Komatsu TL	0.50 m ³	0.66 yd³	610 mm	24"	605 kg	1,334 lb	V
	0.67m ³	0.88 yd³	762 mm	30"	689 kg	1,518 lb	V
	0.85 m ³	1.11 yd³	914 mm	36"	780 kg	1,719 lb	V
	1.02m ³	1.34 yd³	1067 mm	42"	857 kg	1,890 lb	W
	1.20 m ³	1.57 yd³	1219 mm	48"	949 kg	2,092 lb	X

V – Used with weights up to 3,500 lb/yd³ W – Used with weights up to 3,000 lb/yd³
 X – Used with weights up to 2,500 lb/yd³ Y – Used with weights up to 2,000 lb/yd³ Z – Not useable



STANDARD EQUIPMENT

- AM/FM Radio
- Alternator, 60 Ampere, 24v
- Arm, 2925 mm **9'7"** arm assembly
- Auto-decel
- Automatic air conditioner/heater
- Automatic engine warm-up system
- Batteries, large capacity
- Boom and arm holding valve
- Boom, 5700 mm **18'8"**
- Converter, 12v
- Counterweight
- Dry type air cleaner, double element
- Electric horn
- EMMS monitoring system
- Engine, Komatsu SAA4D107E-1-A
- Engine overheat prevention system
- Extended work equipment grease interval
- Fan guard structure
- Fuel system pre-filter 10 micron
- Hydraulic track adjusters (each side)
- KOMTRAX®
- Lock lever
- Mirrors, LH (1), RH (2)
- Multi-function color monitor
- Operator Protective Top Guard (OPG), Level 1
- Pattern change valve ISO /BH (Backhoe)
- Power maximizing system
- PPC hydraulic control system
- Radiator and oil cooler net
- Rear reflector
- Rear view monitoring system (1 camera)
- Revolving frame deck guard
- Revolving frame undercovers
- ROPS cab (ISO 12117-2)
- Seat belt, retractable 78 mm **3"** wide
- Seat, suspension
- Service valve
- Slip resistant foot plates
- Starting motor, 5.5 kW/24v X 1
- Suction fan
- Travel alarm
- Track frame undercover
- Track guiding guard, center section
- Track shoe 800 mm **31.5"** triple grouser
- Working light, two (2) (boom and RH)
- Working mode selection system



OPTIONAL EQUIPMENT

- Cab accessories
 - Rain visor
 - Sun visor
- Cab front guards
 - Lower front window guard
 - Full front guard (Level I)
 - Full front guard (Level II)
 - Bolt on top guard (Level II)
- Working lights two (2) on cab additional front

HB215LG-1

