

KOMATSU®

PC220LC-7

FLYWHEEL HORSEPOWER

125 kW **168 HP** @ 2000 rpm

OPERATING WEIGHT

23940–25033 kg **52,780–55,189 lb**

BUCKET CAPACITY

0.48–1.74 m³ **0.63–2.20 yd³**

**PC
220
LC**

HYDRAULIC EXCAVATOR



Photo may include optional equipment

GALEO

WALK-AROUND

Productivity Features

- **High Production and Low Fuel Consumption**

Production is increased with larger output during Active mode while fuel efficiency is further improved.

- **Maximum Digging Height is 10.3 m 33'10"**,

a benefit in jobs requiring a longer reach.

- **Maximum Drawbar pull Increased 16%** offering superb steering and slope climbing performance.

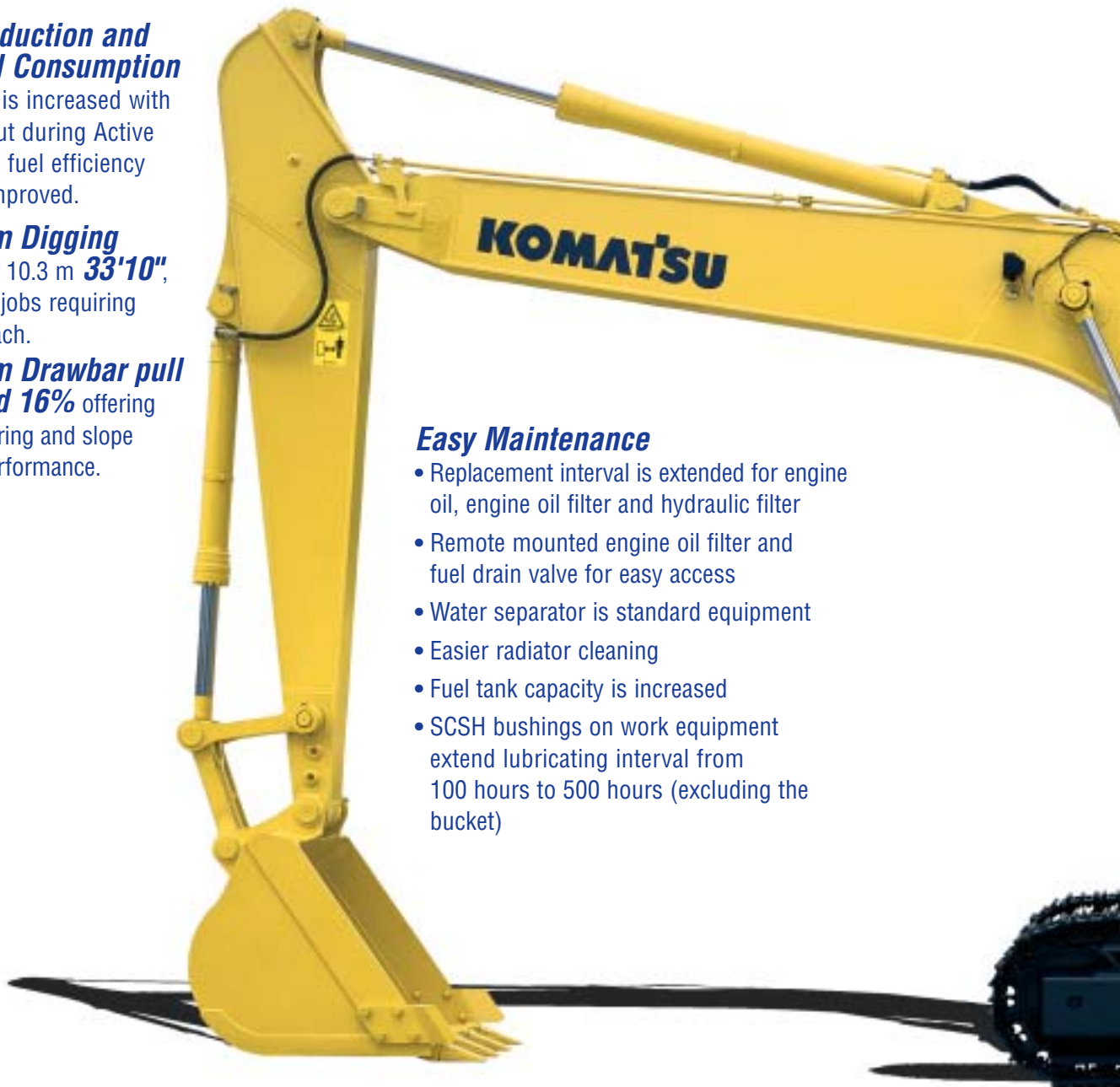

Easy Maintenance

- Replacement interval is extended for engine oil, engine oil filter and hydraulic filter
- Remote mounted engine oil filter and fuel drain valve for easy access
- Water separator is standard equipment
- Easier radiator cleaning
- Fuel tank capacity is increased
- SCSH bushings on work equipment extend lubricating interval from 100 hours to 500 hours (excluding the bucket)

- **Bucket Digging Power Is Increased 21%**
(Over the PC220LC-6)

- **Higher Lifting Capacity**
PC220LC-7's lateral stability is improved, lifting capacity is also increased.

FLYWHEEL HORSEPOWER
125 kW **168 HP** @ 2000 rpm

OPERATING WEIGHT
23940–25033 kg
52,780–55,189 lb

BUCKET CAPACITY
0.48–1.74 m³
0.63–2.20 yd³

Harmony with Environment

- Low emission engine
A powerful turbocharged and air-to-air aftercooled Komatsu SAA6D102E-2 provides 125 kW **168 HP**. The engine is EPA Tier 2 emission certified without sacrificing power or machine productivity.
- Economy mode saves fuel consumption
- Low operation noise

Large Comfortable Cab

New PC220LC-7's cab volume is increased by 14%, offering an exceptionally roomy operating environment

- Highly pressurized cab with air conditioner
- Low noise design
- Low vibration with cab damper mounting



Photo may include optional equipment.

Excellent Reliability and Durability

- High rigidity work equipment
- Sturdy frame structure
- Reliable Komatsu manufactured major components
- Highly reliable electronic devices

GALEO

Komatsu's highly productive, innovative technology, environmentally friendly machines built for the 21st century.

PRODUCTIVITY FEATURES

High Production and Low Fuel Consumption

Engine

The PC220LC-7 gets its exceptional power and work capacity from a Komatsu SAA6D102E-2 engine. Output is 125 kW **168 HP**, providing increased hydraulic power and improved fuel efficiency.

Hydraulics

Unique two-pump system ensures smooth compound movement of the work equipment. HydraMind controls both pumps for efficient engine power use. This system also reduces hydraulic loss during operation.

Large Digging Height

PC220LC-7's maximum digging height is 10.3 m **33'10"**, facilitating jobs that require a longer reach, such as demolition and slope finishing.

Four Working Modes

Working Mode Selection

The PC220LC-7 excavator is equipped with four working modes (**A**, **E**, **L** and **B** mode). Each mode is designed to match engine speed, pump speed, and system pressure with the current application. This provides the flexibility to match equipment performance to the job at hand.

Economy Mode

Economy mode is environmentally friendly. Fuel consumption is reduced 16% (compared with PC220LC-7 Active mode) and production is equal to the PC220LC-6 Heavy-duty mode.

Power Max Function

This function temporarily increases digging force by 7% for added power in tough situations.

Lifting Mode

When the Lifting mode is selected, lifting capacity is increased by 7% by raising hydraulic pressure.

Larger Digging Power Provides Increased Production

$$\begin{array}{ccccc}
 \text{Bucket Digging Force} & & \text{Bucket Digging Speed} & & \text{Bucket Digging Power} \\
 \text{9\% increase} & \times & \text{12\% increase} & = & \text{21\% increase} \\
 1.09 & \times & 1.12 & = & 1.21
 \end{array}$$

Bucket Digging Power is obtained by bucket digging force x bucket digging speed. New PC220LC-7 bucket digging force is increased by 9% and bucket digging speed is increased by 12%, the resulting total bucket digging power is increased 21% (bucket digging force compared with PC220LC-6). The digging force and speed generated result in the largest digging power and the largest production in its class.

Bucket Digging Force*:	SAE 152 kN 15500 kg	34,170 lb
	ISO 172 kN 17500 kg	38,580 lb
Arm Crowd Force*:	SAE 119 kN 12100 kg	26,680 lb
	ISO 129 kN 13200 kg	29,100 lb

*Measured with Power Max function, 3045 mm **10'0"** arm

Working Mode	Application	Advantage
A	Active mode	<ul style="list-style-type: none"> Maximum production/power Fast cycle times
E	Economy mode	<ul style="list-style-type: none"> Excellent fuel economy
L	Lifting mode	<ul style="list-style-type: none"> Hydraulic pressure is increased by 7%
B	Breaker operation	<ul style="list-style-type: none"> Optimum engine rpm, hydraulic flow

Larger Maximum Drawbar Pull

PC220LC-7's maximum drawbar pull is increased by 16%, provides superb steering and slope climbing performance.

16% increase

Maximum drawbar pull: 202 kN 20570 kg **45,350 lb**
 Drawbar pull/operating weight: 0.91

Automatic Three-Travel Speed

Travel speed is automatically shifted from high to low speed according to the pressure of the travel.

	High	Mid	Low
Travel Speed	5.5 km/h 3.4 mph	4.2 km/h 2.6 mph	3.1 km/h 1.9 mph

Multi-Function Color Monitor

A newly developed Multi-Function Color Monitor has multiple functions, such as Working mode selection, hydraulic pump oil flow adjustment for matching to attachment, and maintenance interval notice, etc.

Working Mode Selection

The Multi-Function Color Monitor allows for easy selection of the working modes (A, E, L and B modes).

EMMS (Equipment Management Monitoring System)

Monitor Function

Controller monitors engine oil level, coolant temperature, battery charge and air clogging, etc. If the controller finds any abnormality, it is displayed.

Maintenance Function

The monitor informs replacement time of oil, filters and other maintenance items when the designated interval is reached.

Trouble Data Memory Function

The monitor stores machine abnormalities for effective troubleshooting.



Excellent Reliability and Durability

• High Rigidity Work Equipment

The arm and boom are strengthened to correspond to increasing bucket and arm digging forces. The arm and boom cross sectional strength are also increased 25% and 8% respectively. The boom and arm have large cross-sectional dimensions as well as continuous groove welding, improving digging and side-contact strength.

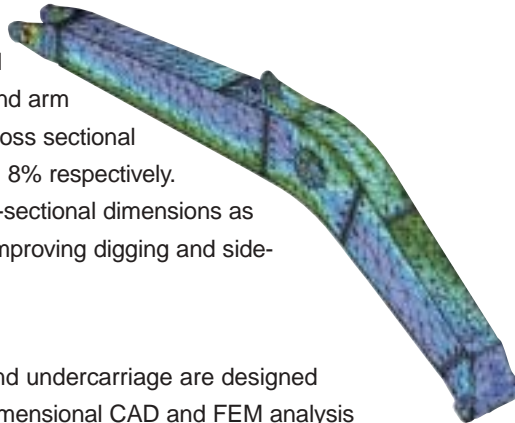

• Sturdy Frame Structure

The revolving frame, center frame and undercarriage are designed by using the most advanced three-dimensional CAD and FEM analysis technology.

• Reliable Components

All of the major machine components, such as engine, hydraulic pumps, hydraulic motors and control valves, etc., are exclusively designed and manufactured by Komatsu.

• Highly Reliable Electronic Devices

Exclusively designed electronic devices have passed severe testing.

- Controller
- Sensors
- Connectors
- Heat resistant wiring

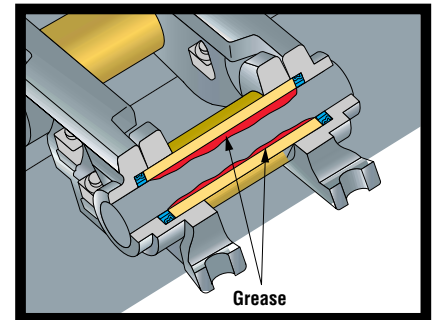

Grease Sealed Track provides excellent undercarriage durability

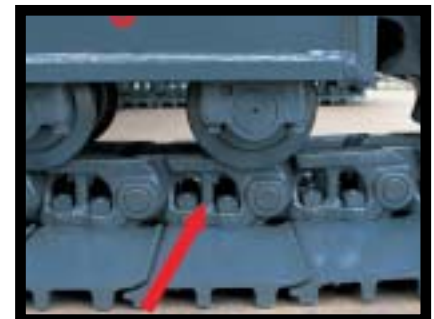

*Track Link with Strut
PC220LC-7 uses track links with strut providing superb durability*

WORKING ENVIRONMENT

PC220LC-7 cab interior is spacious and provides a comfortable working environment...

Large Comfortable Cab

Comfortable Cab

New PC220LC-7's cab volume is increased by 14%, offering an exceptionally comfortable operating environment. The large cab enables full flat reclining of the seat back.

Pressurized Cab

The air conditioner, air filter and a higher internal air pressure (6.0 mm Aq **0.2" Aq**) prevent external dust from entering the cab.

Low Noise Design

Noise level is remarkably reduced, not only engine noise but also noise when swinging and hydraulic relief.

Low Vibration with Cab Damper Mounting

PC220LC-7 uses new, improved multi-layer viscous mount system that incorporates longer stroke and the addition of a spring. The new cab damper mounting combined with strengthened left and right side decks aids vibration reduction at operator seat.

Vibration at floor is reduced from 120 dB (VL) to 115 dB (VL).

dB (VL) is index for expressing size of vibration.

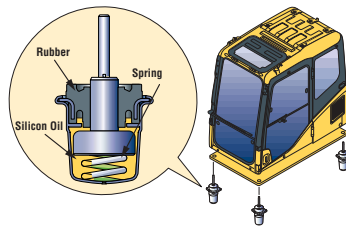

Washable Cab Floor Mat
The PC220LC-7's cab floor mat is easy to keep clean. The gently inclined surface has a flanged floor mat and drainage holes to facilitate runoff.

Comparison of Riding Comfort

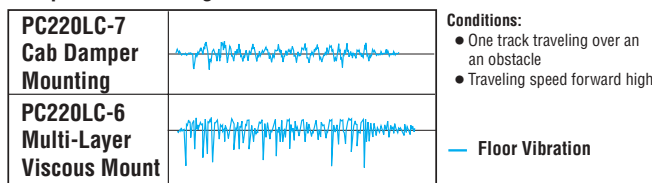

Pitch vertical direction on graph shows size of vibration.

Safety Features

Wide Visibility

The right side window pillar has been removed and the rear pillar reshaped to provide better visibility. Blind spots have been decreased by 34%.

Pump/engine room partition

prevent oil from spraying on the engine if a hydraulic hose should burst.

Thermal and fan guards are placed around high-temperature parts of the engine and fan drive.

Steps with non-skid sheet and large handrail. Steps with non-skid sheet provide anti-slip footing for maintenance.



Photo may include optional equipment.

Multi-Position Controls

The multi-position, pressure proportional control levers allow the operator to work in comfort while maintaining precise control. A double-slide mechanism allows the seat and controllers to move together or independently, allowing the operator to position the controllers for maximum productivity and comfort.



Seat Sliding Amount: 340 mm 13.4", increased 120 mm 4.7"



Large Handrail



Thermal Guard



Defroster



Cab Frame Mounted Wiper



Bottle Holder and Magazine Rack

MAINTENANCE FEATURES

Easy Maintenance

Komatsu designed the PC220LC-7 to have easy service access. We know by doing this, routine maintenance and servicing are less likely to be skipped, which can mean a reduction in costly downtime later on. Here are some of the many service features found on the PC220LC-7.

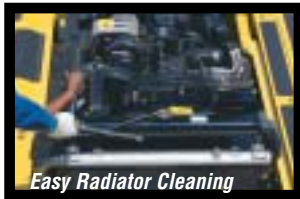

Easy Radiator Cleaning

- **Easy Radiator Cleaning**
Clearance between radiator and oil cooler is increased to facilitate radiator core cleaning with an air nozzle.

- **Water Separator** is standard equipment, removing water mixed in fuel and preventing fuel system damage.



Water Separator



Remote Mounted Engine Oil Filter

- **Easy Access to Engine Oil Filter and Fuel Drain Valve.** Engine oil filter and fuel drain valve are remotely mounted to improve accessibility.

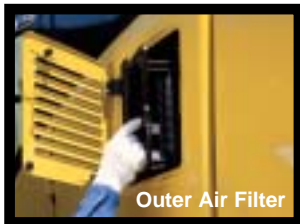

Outer Air Filter

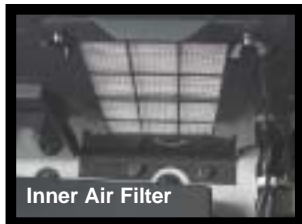

Inner Air Filter

Removal and installation of air conditioner filter element, without tools, facilitates cleaning.

- **Easy Cab Filter Maintenance**

Tool free removal of the internal and external cab filters.

- **Fuel Tank Capacity Increased**

Fuel tank capacity is increased from 340 ltr **89.8 U.S. gal** to 400 ltr **105.7 U.S. gal** to extend operating hours before refueling. The fuel tank is treated for rust prevention and improved corrosion resistance.

Reducing Maintenance Costs

- **Hydraulic Oil and Filter/Engine Oil and Filter Replacement Interval Extended**

The new high performance filters are used in the hydraulic circuit and engine. Hydraulic oil filter, engine oil, and engine oil filter element replacement intervals are significantly extended to reduce maintenance costs.

Comparison of Replacement Intervals unit: hours

	PC220LC-7	PC220LC-6
Engine oil	500	250
Engine oil filter	500	250
Hydraulic oil	5,000	5,000
Hydraulic oil filter	1,000	500

High-Pressure In-Line Filters

Protects the hydraulic system from debris in the event of pump failure.



SPECIFICATIONS



ENGINE

Model Komatsu SAA6D102E-2
 Type Water-cooled, 4-cycle, direct injection
 Aspiration Turbocharged and air-air aftercooling
 Number of cylinders 6
 Bore 102 mm **4.02"**
 Stroke 120 mm **4.72"**
 Piston displacement 5.88 ltr **359 in³**
 Power rating (*SAE J1349 conditions)
 *Gross 133 kW **178 HP** @ 2000 rpm
 Flywheel 125 kW **168 HP** @ 2000 rpm
 Governor All-speed control, mechanical
 EPA, EU, and Japan Tier 2 emissions certified.



HYDRAULICS

Type HydrauMind (Hydraulic Mechanical Intelligence New Design) system, closed-center system with load sensing valves and pressure compensated valves
 Number of selectable working modes 4
 Main pump:
 Type Variable displacement piston type
 Pumps for Boom, arm, bucket, swing, and travel circuits
 Maximum flow 439 ltr/min **116 U.S. gal/min**
 Supply for control circuit Self-reducing valve
 Hydraulic motors:
 Travel 2 x axial piston motor with parking brake
 Swing 1 x axial piston motor with swing holding brake
 Relief valve setting:
 Implement circuits 37.3 MPa 380 kgf/cm² **5,400 psi**
 Travel circuit 37.3 MPa 380 kgf/cm² **5,400 psi**
 Swing circuit 28.4 MPa 290 kgf/cm² **4,125 psi**
 Pilot circuit 3.2 MPa 33 kgf/cm² **470 psi**
 Hydraulic cylinders:
 (Number of cylinders – bore x stroke x rod diameter)
 Boom 2–135 mm x 1335 mm x 90 mm **5.3" x 52.5" x 3.5"**
 Arm 1–140 mm x 1635 mm x 100 mm **5.5" x 64.4" x 3.9"**
 Bucket: 1–130 mm x 1020 mm x 90 mm **5.1" x 40.2" x 3.5"**



DRIVES AND BRAKES

Steering control Two levers with pedals
 Drive method Hydrostatic
 Maximum drawbar pull 202 kN 20570 kg **45,350 lb**
 Gradeability 70%, 35°
 Maximum travel speed: High 5.5 km/h **3.4 mph**
 (Auto-Shift) Mid 4.2 km/h **2.6 mph**
 Low 3.1 km/h **1.9 mph**
 Service brake Hydraulic lock
 Parking brake Mechanical disc brake



SWING SYSTEM

Drive method Hydrostatic
 Swing reduction Planetary gear
 Swing circle lubrication Grease-bathed
 Service brake Hydraulic lock
 Holding brake/Swing lock Mechanical disc brake
 Swing speed 11.7 rpm
 Swing torque 7691 kg.m **55,609 ft lbs**



UNDERCARRIAGE

Center frame X-frame
 Track frame Box-section
 Seal of track Sealed track
 Track adjuster Hydraulic
 Number of shoes (each side): 51
 Number of carrier rollers 2 each side
 Number of track rollers (each side): 10



COOLANT AND LUBRICANT CAPACITY (REFILLING)

Fuel tank 400 ltr **105.7 U.S. gal**
 Coolant 30.9 ltr **8.2 U.S. gal**
 Engine 24.0 ltr **6.3 U.S. gal**
 Final drive, each side 4.5 ltr **1.2 U.S. gal**
 Swing drive 6.6 ltr **1.7 U.S. gal**
 Hydraulic tank 143 ltr **37.8 U.S. gal**



OPERATING WEIGHT (APPROXIMATE)

Operating weight including 5850 mm **19'2"** one-piece boom, 3045 mm **10'0"** arm, SAE heaped 1.0 m³ **1.31 yd³** backhoe bucket, rated capacity of lubricants, coolant, full fuel tank, operator, and standard equipment.

Shoes	PC220LC-7	
	Operating Weight	Ground Pressure
700 mm 28"	24200 kg 53,350 lb	0.42 kgf/cm ² 5.97 psi
800 mm 31.5"	24510 kg 54,046 lb	0.37 kgf/cm ² 5.26 psi

PC220LC-7 HYDRAULIC EXCAVATOR



DIMENSIONS

	Arm Length	3045 mm	10'0"	3505 mm	11'6"
A	Overall length	9885 mm	32'5"	9910 mm	32'6"
B	Length on ground (transport):	5390 mm	17'8"	4950 mm	16'3"
C	Overall height (to top of boom)	3160 mm	10'4"	3270 mm	10'9"
D	Overall width	3380 mm	11'1"	3380 mm	11'1"
E	Overall height (to top of cab)	3015 mm	9'11"	3015 mm	9'11"
F	Ground clearance, counterweight	1100 mm	3'7"	1100 mm	3'7"
G	Ground clearance (minimum)	440 mm	1'5"	440 mm	1'5"
H	Tail swing radius	2940 mm	9'8"	2940 mm	9'8"
I	Track length on ground	3845 mm	12'7"	3845 mm	12'7"
J	Track length	4640 mm	15'3"	4640 mm	15'3"
K	Track gauge	2580 mm	8'6"	2580 mm	8'6"
L	Width of crawler	3380 mm	11'1"	3380 mm	11'1"
M	Shoe width	800 mm	31.5"	800 mm	31.5"
N	Grouser height	25 mm	1.0"	25 mm	1.0"
O	Machine cab height	2110 mm	6'11"	2110 mm	6'11"
P	Machine cab width	2710 mm	8'11"	2710 mm	8'11"
Q	Distance, swing center to rear end	2905 mm	9'6"	2905 mm	9'6"

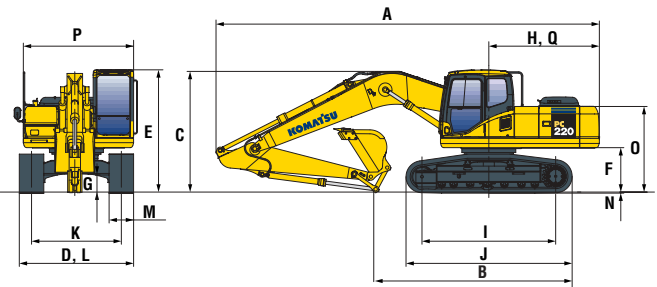

WORKING RANGE

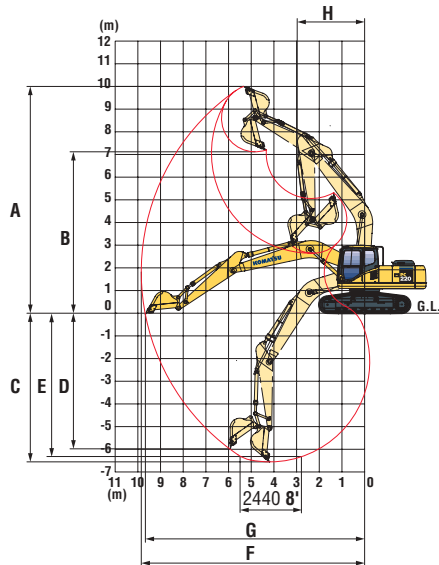

	Arm	3045 mm	10'0"	3505 mm	11'6"
A	Max. digging height	10000 mm	32'10"	10300 mm	33'10"
B	Max. dumping height	7035 mm	23'1"	7360 mm	24'2"
C	Max. digging depth	6920 mm	22'8"	7320 mm	24'0"
D	Max. vertical wall digging depth	6010 mm	19'9"	6230 mm	20'5"
E	Max. digging depth of cut for 8' level	6700 mm	22'0"	7150 mm	23'5"
F	Max. digging reach	10180 mm	33'5"	10580 mm	34'8"
G	Max. digging reach at ground level	10020 mm	32'10"	10420 mm	34'2"
H	Min. swing radius	3450 mm	11'4"	3340 mm	10'11"
SAE rating	Bucket digging force at power max.	15500 kgf		15500 kgf	
		34,170 lb		34,170 lb	
ISO rating	Arm crowd force at power max.	12100 kgf		10900 kgf	
		26,680 lb		24,030 lb	
ISO rating	Bucket digging force at power max.	17500 kgf		17500 kgf	
		38,580 lb		38,580 lb	
ISO rating	Arm crowd force at power max.	13200 kgf		11200 kgf	
		29,100 lb		24,690 lb	



BACKHOE BUCKET, ARM, AND BOOM COMBINATION

Bucket Type	Bucket				Arms				
	Capacity		OLW	Weight	Number of Teeth	10'0"	11'6"		
Komatsu "H" Series HD	0.54 m ³	0.70 yd³	610 mm	24"	732 kg	1,614 lb	3	V	V
	0.72 m ³	0.94 yd³	762 mm	30"	845 kg	1,862 lb	4	V	V
	0.90 m ³	1.18 yd³	914 mm	36"	912 kg	2,011 lb	4	V	V
	1.09 m ³	1.43 yd³	1067 mm	42"	1019 kg	2,247 lb	5	V	W
	1.28 m ³	1.67 yd³	1219 mm	48"	1092 kg	2,407 lb	6	W	X
	1.49 m ³	1.95 yd³	1219 mm	48"	1116 kg	2,461 lb	6	X	Y
Komatsu "H" Series SD	0.48 m ³	0.63 yd³	610 mm	24"	770 kg	1,698 lb	3	V	V
	0.67 m ³	0.87 yd³	762 mm	30"	890 kg	1,963 lb	4	V	V
	0.85 m ³	1.11 yd³	914 mm	36"	969 kg	2,137 lb	4	V	V
	1.03 m ³	1.35 yd³	1067 mm	42"	1078 kg	2,377 lb	5	V	W
	1.22 m ³	1.60 yd³	1219 mm	48"	1188 kg	2,619 lb	6	W	X

V – Used with weights up to 3,500 lb/yd³, W – Used with weights up to 3,000 lb/yd³

X – Used with weights up to 2,500 lb/yd³, Y – Used with weights up to 2,000 lb/yd³, Z – Not useable



LIFTING CAPACITY

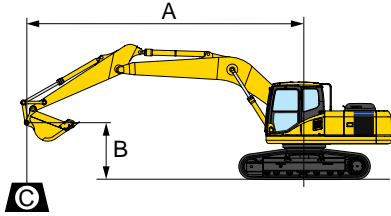

- A: Reach from swing center
- B: Bucket hook height
- C: Lifting capacity
- Cf: Rating over front
- Cs: Rating over side
- ⊗: Rating at maximum reach

Conditions:

- Boom length 5850 mm 19'2"
- Bucket 1.0 m³ 1.31 yd³ (SAE heaped)
- Bucket weight 734 kg 1620 lb
- Track shoes: -800 mm 31.5"

PC220LC-7		Arm: 3048 mm 10'0"											
A	B	1.5 m 5'		3.0 m 10'		4.6 m 15'		6.1 m 20'		7.6 m 25'		⊗ MAX	
		Cf	Cs	Cf	Cs	Cf	Cs	Cf	Cs	Cf	Cs	Cf	Cs
7.6 m 25'								*4750 kg *10,500 lb	*4750 kg *10,500 lb			*3150 kg *7,000 lb	*3150 kg *7,000 lb
6.1 m 20'								*4950 kg *10,900 lb	*4950 kg *10,900 lb	*4050 *8900	*4050 *8900	*3050 kg *6,700 lb	*3050 kg *6,700 lb
4.6 m 15'								*5800 kg *12,800 lb	*5800 kg *12,800 lb	*6600 kg *12,300 lb	4050 kg 9,000 lb	*3050 kg *6,700 lb	*3050 kg *6,700 lb
3.0 m 10'				*14000 kg *30,900 lb	*14000 kg *30,900 lb	*8900 kg *19,700 lb	*8900 kg *19,700 lb	*7100 kg *15,600 lb	5700 kg 12,600 lb	6050 kg 13,300 lb	3900 kg 8,700 lb	*3200 kg *7,100 lb	2950 kg 6,500 lb
1.5 m 5'				*7400 kg *16,300 lb	*7400 kg *16,300 lb	*11550 kg *25,500 lb	8400 kg 18,500 lb	*8450 kg *18,700 lb	5400 kg 11,900 lb	5900 kg 13,000 lb	3750 kg 8,300 lb	*3550 kg *7,800 lb	2850 kg 6,300 lb
0 m 0'				*8400 kg *18,500 lb	*8400 kg *18,500 lb	*13350 kg *29,400 lb	7950 kg 17,600 lb	8200 kg 18,100 lb	5150 kg 11,300 lb	5750 kg 12,600 lb	3650 kg 8,000 lb	*4050 kg *9,000 lb	2900 kg 6,400 lb
-1.5 m -5'		*7450 kg *16,400 lb	*7450 kg *16,400 lb	*12000 kg *26,400 lb	*12000 kg *26,400 lb	13150 kg 29,000 lb	7800 kg 17,200 lb	8050 kg 17,800 lb	5000 kg 11,100 lb	4450 kg 12,500 lb	2650 kg 7,900 lb	5000 kg 1,100 lb	3150 kg 6,900 lb
-3.0 m -10'		*11550 kg *25,500 lb	*11550 kg *25,500 lb	*17250 kg *38,100 lb	15850 kg 34,900 lb	13200 kg 29,100 lb	7800 kg 17,200 lb	8050 kg 17,800 lb	5000 kg 11,000 lb			5900 kg 13,900 lb	3700 kg 8,200 lb
-4.6 m -15'				*18100 kg *39,900 lb	16300 kg 35,900 lb	*12450 kg *27,500 lb	8000 kg 17,700 lb	8250 kg 18,200 lb	5150 kg 11,400 lb			8100 kg 17,900 lb	5100 kg 11,200 lb

* Load is limited by hydraulic capacity rather than tipping. Ratings are based on SAE Standard No. J1097. Rated loads do not exceed 87% of hydraulic lift capacity or 75% of tipping load.

PC220LC-7		Arm: 3505 mm 11'6"											
A	B	1.5 m 5'		3.0 m 10'		4.6 m 15'		6.1 m 20'		7.6 m 25'		⊗ MAX	
		Cf	Cs	Cf	Cs	Cf	Cs	Cf	Cs	Cf	Cs	Cf	Cs
7.6 m 25'												*2435 kg *5,370 lb	*2435 kg *5,370 lb
6.1 m 20'										*3805 kg *8,300 lb	*3805 kg *8,300 lb	*2355 kg *5,200 lb	*2355 kg *5,200 lb
4.6 m 15'								*5155 kg *11,300 lb	*5155 kg *11,300 lb	*5060 kg *11,100 lb	4020 kg 8,800 lb	*2405 kg *5,300 lb	*2405 kg *5,300 lb
3.0 m 10'				*11525 kg *25,400 lb	*11525 kg *25,400 lb	*7905 kg *17,400 lb	*7905 kg *17,400 lb	*6455 kg *14,200 lb	5670 kg 12,500 lb	*5755 kg *12,600 lb	3860 kg 8,500 lb	*2565 kg *5,650 lb	*2565 kg *5,650 lb
1.5 m 5'				*11610 kg *25,500 lb	*11610 kg *25,500 lb	*10665 kg *23,500 lb	8345 kg 18,400 lb	*7895 kg *17,400 lb	5305 kg 11,600 lb	5770 kg 12,700 lb	3670 kg 8,000 lb	*2850 kg *6,200 lb	2585 kg 5,700 lb
0 m 0'		*4330 kg *9,500 lb	*4330 kg *9,500 lb	*9835 kg *21,600 lb	*9835 kg *21,600 lb	*12715 kg *28,000 lb	7795 kg 17,100 lb	8045 kg 17,700 lb	5005 kg 11,000 lb	5595 kg 12,300 lb	3510 kg 7,700 lb	*3310 kg *7,300 lb	2615 kg 5,700 lb
-1.5 m -5'		*7440 kg *16,400 lb	*7440 kg *16,400 lb	*12165 kg *26,800 lb	*12165 kg *26,800 lb	12845 kg 28,300 lb	7540 kg 16,600 lb	7845 kg 17,300 lb	4830 kg 10,600 lb	5485 kg 12,000 lb	3410 kg 7,500 lb	*4095 kg *9,000 lb	2815 kg 6,200 lb
-3.0 m -10'		*10755 kg *23,700 lb	*10755 kg *23,700 lb	*16115 kg *35,500 lb	15265 kg 33,600 lb	12810 kg 28,200 lb	7505 kg 16,500 lb	7800 kg 17,100 lb	4790 kg 10,500 lb	5480 kg 12,000 lb	3405 kg 7,500 lb	5290 kg 11,600 lb	3290 kg 7,200 lb
-4.6 m -15'		*14705 kg *32,400 lb	*14705 kg *32,400 lb	*18990 kg *41,800 lb	15660 kg 34,500 lb	*12865 kg *28,300 lb	7665 kg 16,900 lb	7920 kg 17,460 lb	4900 kg 10,800 lb			7045 kg 15,500 lb	4385 kg 9,600 lb

* Load is limited by hydraulic capacity rather than tipping. Ratings are based on SAE Standard No. J1097. Rated loads do not exceed 87% of hydraulic lift capacity or 75% of tipping load.



STANDARD EQUIPMENT

- Air conditioner with defroster
- Alternator, 50 Ampere, 24V
- Auto-Decel
- Automatic deaeration system for fuel line
- Automatic engine warm-up system
- Batteries, large capacity
- Boom and arm holding valve
- Cab
- Counterweight 5050 kg **11,133 lb**
- Dry type air cleaner, double element
- Electric horn
- Engine, Komatsu SAA6D102E-2
- Engine overheat prevention system
- Fan guard structure
- High pressure hydraulic filters
- Hydraulic track adjusters (each side)
- Multi-function color monitor
- Power maximizing system
- PPC hydraulic control system
- Radiator and oil cooler dustproof net
- Rearview mirror, RH, LH
- Revolving frame deck guard
- Seat belt, retractable
- Seat, suspension
- Service valve (1 additional)
- Shoes, triple grouser: 800 mm **31.5"**
- Track guiding guard, center section
- Travel alarm
- Working light, 2 (boom and RH)
- Working mode selection system



OPTIONAL EQUIPMENT

- Arms
 - 3045 mm **10'0"** arm assembly
 - 3045 mm **10'0"** HD arm assembly with piping
 - 3500 mm **11'6"** arm assembly
- Boom
 - 5850 mm **19'2"** boom
 - 5850 mm **19'2"** HD boom with piping
- Cab front and top guards
- Converter, 12V
- Hydraulic control units
- Pattern change valve
- Rain visor
- Shoes, triple grouser: 700 mm **28"**
- Straight travel pedal
- Sun visor
- Track frame undercover
- Track roller guards (full length)
- Tropical door



ATTACHMENT OPTIONS

- Buckets
 - Lug bushing
 - Play adjustment mechanism
 - Komatsu breakers/hammers
 - Komatsu plate compactors
 - Lincoln autolube systems
 - JRB couplers
 - PSM thumbs
- For a complete line up of available attachments, please contact your local Komatsu distributor**

AESS586-03

©2005 Komatsu Printed in USA

DK06(3M)C

06/05(EV-1)

KOMATSU®

440 N. Fairway Drive
P.O. Box 8112
Vernon Hills, IL 60061-8112



www.KomatsuAmerica.com

Materials and specifications are subject to change without notice
KOMATSU is a trademark of Komatsu Ltd. Japan