

KOMATSU®

PC78US-8

NET HORSEPOWER

41 kW **55 HP**

OPERATING WEIGHT

7365 kg **16,240 lb**

PC
78US



COMPACT HYDRAULIC
EXCAVATOR

Photo may include optional equipment.

WALK-AROUND

Performance and Versatility

- Standard auxiliary hydraulics
- Five working modes: Power, Economy, Lifting, Attachment, Breaker
- Three track options: rubber, steel, roadliner
- Automatic two-speed travel
- ISO/SAE pattern change valve

Service and Maintenance

- Wide-opening engine hood and side covers
- Side-by-side radiator and oil cooler are easily inspected
- Extended lubrication intervals
- Ground level maintenance
- Easy access to engine oil filter, engine main fuel filter, and fuel drain valve



KOMTRAX[®]

KOMTRAX equipped machines can send location, SMR and operation maps to a secure website utilizing wireless technology. Machines also relay error codes, cautions, maintenance items, fuel levels, and much more.

NET HORSEPOWER
41 kW 55 HP

OPERATING WEIGHT
7365 kg 16,240 lb

DIG DEPTH
4710 mm 15'5"

Operator Comfort

- Large cab with air conditioner
- Fully adjustable suspension seat with retractable seat belt
- Pilot proportional joystick controls are low effort
- Easy-to-see 7" multi-function color monitor
- Low-noise cab



Value, Durability, and Strength

- KOMTRAX® wireless equipment monitoring system
- High strength X-track frame
- Castings are used for boom foot and tip
- O-ring face seal hydraulic fittings
- Moisture/dust resistant electrical connectors

Peace of Mind

- Spacious cab with excellent visibility
- Neutral engine start system
- Thermal and fan guards
- Low emission Komatsu engine with dual element air cleaner
- One key operates the ignition and all machine locks

OPERATOR ENVIRONMENT



Operator Station

- Spacious cab with unobstructed floor provides the operator with ample leg room
- Large travel pedals
- Upper rail sliding door
- Air conditioning provides a comfortable operating environment
- Fully adjustable suspension seat reduces operator fatigue
- PPC joystick controls are low effort and provide fine control
- 7" color monitor is easy to see and operate

FEATURES



Tight Tail Swing

The operator can focus more on the work in front and worry less about rear swing clearance, even in confined areas with only an 80 mm 3.1" projection over the tracks.

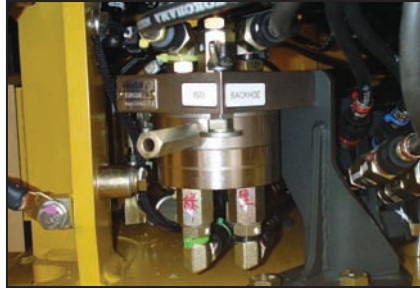

Pattern Change Valve

Whether you are comfortable with ISO or SAE, you can easily change from one to the other.



Excellent Visibility

The operator's station design allows the operator to maintain a 360° field-of-view.



7" Color LCD Monitor

The liquid crystal display can be easily read at various angles and lighting conditions. Simple and easy to operate switches. Industry-first function keys facilitate multi-function operations. Displays data in 12 languages.



Ground Level Maintenance

With the left and right side service doors, it is possible to access the major maintenance points from ground level.



Side-by-side Cooling

Since oil cooler, aftercooler and radiator are arranged side-by-side, it is easy to clean, remove, and install them. Radiator, aftercooler, and oil cooler made of aluminum have high cooling efficiency and are easily recycled.



Neutral Engine Start System

Locks out drives and hydraulics during machine start up.



Manual Selector Valve

Allows the operator to switch between one-way (Breaker) and two-way (Thumb) auxiliary hydraulic flow.

Extended Maintenance Intervals

Lubricate swing circle	500 hrs
Lubricate boom & arm	500 hrs
Replace engine oil and filter	500 hrs
Replace fuel pre-filter cartridge	500 hrs
Replace fuel main filter	1000 hrs
Replace hydraulic filter	1000 hrs

Three Track Options Available



Rubber

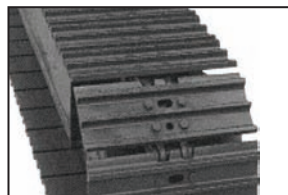

Steel



Roadliner

SPECIFICATIONS



ENGINE

Model Komatsu SAA4D95LE-5*
 Type Water cooled, 4-cycle, direct injection
 Aspiration Turbocharged, and air-to-air aftercooled
 Number of cylinders 4
 Piston displacement 3.26 ltr **199 in³**
 Horsepower:
 Net (ISO 9249/SAE J1349) 41 kW **55 HP @ 1950 rpm**

*EPA Interim Tier 4 and EU Stage 3A certified.



ELECTRICAL SYSTEM

Operating voltage 24 V
 Battery 55 Ah/2 x 12 V
 Alternator 35 A
 Starter 4.5 kW



HYDRAULIC SYSTEM

Type HydraulMind (Hydraulic Mechanical Intelligence New Design) system, Closed-center system with load-sensing valve and pressure-compensated valve

Main pumps:

Type Variable displacement, axial piston
 Maximum flow 160 ltr/min **42.3 U.S. gal/min**

Type Fixed displacement gear
 Maximum flow 63 ltr/min **16.6 U.S. gal/min**

Hydraulic motors:

Travel 2 x piston motor with parking brake
 Swing 1 x piston motor with swing holding brake

Relief valve setting:

Implement, travel circuit 26.5 MPa 270 kgf/cm² **3,840 psi**
 Swing circuit 20.6 MPa 210 kgf/cm² **2,990 psi**
 Blade circuit (Raise) 12.7 MPa 130 kgf/cm² **1,850 psi**
 (Lower) 21.1 MPa 215 kgf/cm² **3,060 psi**



PERFORMANCE

Travel speed
 High 5.0 km/hr **3.1 mph**
 Low 2.9 km/hr **1.8 mph**
 Swing speed 10 rpm
 Ground pressure 0.34 kg/cm² **4.83 psi**
 Max. drawbar pull 66.9 kN 6820 kgf **15,050 lbf**
 Gradeability 35°
 Bucket digging force (ISO) 6250 kg **13,780 lb**
 Arm crowd force (ISO) 3520 kg **7,760 lb**



SWING SYSTEM

Driven by Hydraulic motor
 Swing reduction Planetary gear
 Swing circle lubrication Grease-bathed
 Swing lock Mechanical disc brake



DRIVES AND BRAKES

Steering control Two levers with pedals
 Drive method Fully hydrostatic
 Service brake Hydraulic lock
 Parking brake Mechanical disc



UNDERCARRIAGE

Center frame X-frame
 Track frame Box-section
 Track type Sealed track
 Track adjuster Hydraulic
 Number of carrier rollers (each side) 1
 Number of track rollers (each side) 5



REFILL CAPACITIES

Fuel tank	125 ltr	33.0 U.S. gal
Radiator	10 ltr	2.6 U.S. gal
Engine	11.0 ltr	2.9 U.S. gal
Final drive, each side	1.1 ltr	0.3 U.S. gal
Swing drive	2.0 ltr	0.5 U.S. gal
Hydraulic tank	56 ltr	14.8 U.S. gal



OPERATING WEIGHT (APPROXIMATE)

Operating weight including 3710 mm **12'2"** one-piece boom, 2250 mm **7'5"** arm, SAE heaped 0.28 m³ **0.37 yd³** backhoe bucket, cab, rubber shoe, blade, rated capacity of lubricants, coolant, full fuel tank, operator, and other standard equipment.

Operating weight 7365 kg **16,240 lb**



DIMENSIONS

A	Overall length	6295 mm 20'8"
B	Overall width	2330 mm 7'8"
C*	Overall height	2730 mm 8'11"
D	Tail swing radius	1240 mm 4'1"
E	Crawler length	2840 mm 9'4"
F	Track gauge	1870 mm 6'2"
G	Width of crawler	2320 mm 7'7"
H	Track shoe width	450 mm 17.7"
I	Machine cab height	1835 mm 6'0"
J	Machine cab width	2330 mm 7'8"
K	Distance swing center to rear end	1405 mm 4'7"

* including grouser height

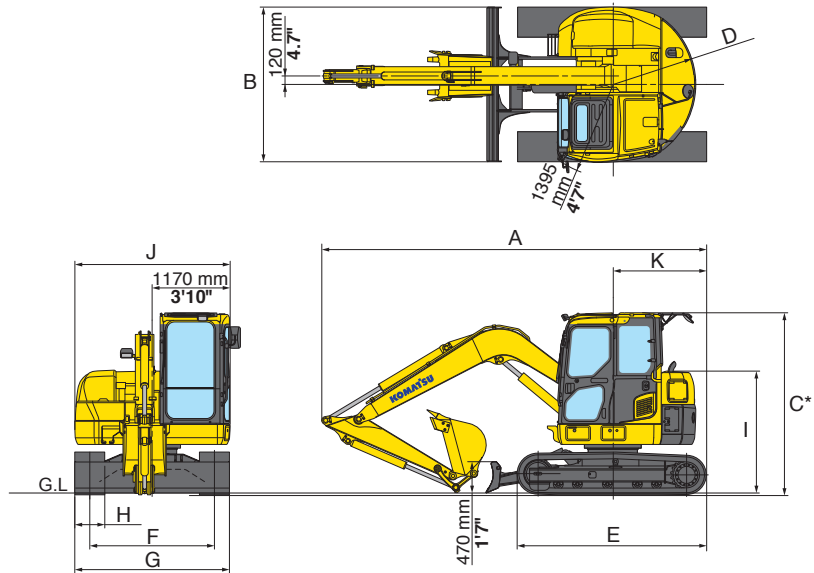

WORKING RANGE

	Boom Length	3710 mm 12'2"
	Arm Length	2250 mm 7'5"
A	Maximum digging height	7600 mm 24'11"
B	Maximum dumping height	5500 mm 18'1"
C	Maximum digging depth	4710 mm 15'5"
D	Maximum vertical wall digging depth	4030 mm 13'3"
E	Maximum digging depth of cut for 2440 mm 8' level	4430 mm 14'6"
F	Maximum digging reach	6920 mm 22'8"
G	Maximum digging reach at ground	6790 mm 22'3"
H	Minimum digging reach at ground	1735 mm 5'8"
I	Minimum swing radius	2050 mm 6'9"

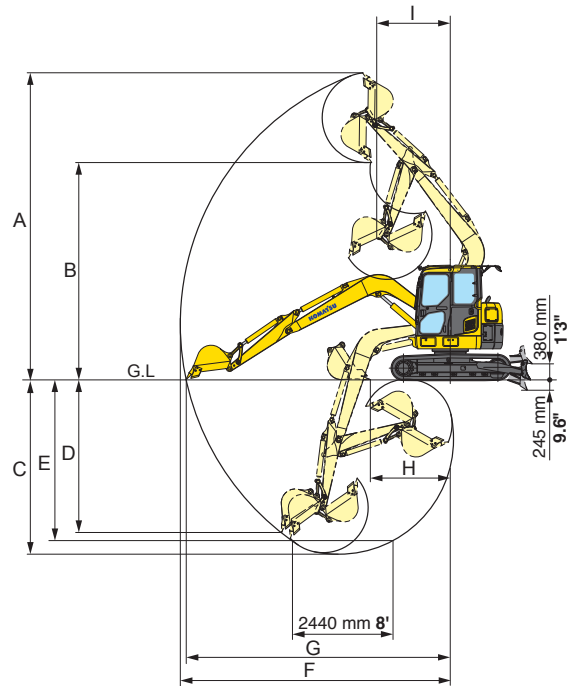

LIFTING CAPACITY

Blade on ground		Unit: kgf lbf							
		1.5 m 4'11"		3.0 m 9'10"		4.5 m 14'9"		Maximum Reach	
		Front	Side	Front	Side	Front	Side	Front	Side
Arm Length 2250 mm 7'5"	5 m 16'5"	—	—	—	—	1490* 3290*	1260 2780	1420* 3140*	1150 2540
	3 m 9'10"	—	—	1870* 4130*	1870* 4130*	1570* 3470*	1230 2710	1350* 2990*	770 1700
	0 m 0'	—	—	3320* 7330*	2020 4460	2090* 4600*	1060 2350	1520* 3360*	680 1510
	-2 m 6'7"	4230* 9330*	4230* 9330*	3010* 6640*	1950 4300	1880* 4140*	1020 2260	1540* 3400*	870 1920

*Load is limited by hydraulic capacity rather than tipping. Ratings are based on SAE Standard No. J1097. Rated loads do not exceed 87% of hydraulic capacity or 75% of tipping load.



STANDARD EQUIPMENT

- 7" color multi-function monitor
- Additional counterweight, 220 kg **485 lb**
- Air cleaner, dry type, double element with auto dust evacuator
- Alternator, 35A
- Arm, 2250 mm **7'5"** arm assembly
- Automatic air conditioner
- Automatic two-speed travel control
- Auxiliary hydraulics with selector valve
- Backfill blade
- Batteries, 55Ah/2 x 12V
- Boom, 3710 mm **12'2"**
- Cab which includes: floor mat, intermittent front windshield wiper and washer, large ceiling hatch, pull-up front window, removable lower windshield
- Cooling fan, suction type
- KOMTRAX®
- Rearview mirrors (LH, rear)
- Starting motor 4.5 kW
- Suspension seat with 78 mm **3"** wide retractable seat belt
- Travel alarm
- Work light on boom
- Work light on cab



OPTIONAL EQUIPMENT

- Additional work light on cab
- Shoes
 - 450 mm **17.7"** rubber shoe
 - 450 mm **17.7"** Roadliner
 - 450 mm **17.7"** triple grouser
 - 600 mm **23.6"** triple grouser

KOMATSU®