

# KOMATSU®

## WA200-6

**NET HORSEPOWER**  
94 kW **126 HP** @ 2000 rpm

**OPERATING WEIGHT**  
10505 - 10765 kg  
**23,160 - 23,733 lb**

**BUCKET CAPACITY**  
1.7 - 2.4 m<sup>3</sup> **2.2 - 3.1 yd<sup>3</sup>**

**WA**  
**200**

W  
H  
E  
E  
L  
L  
O  
A  
D  
E  
R



Photo may include optional equipment.

# WALK-AROUND

## *High Productivity & Low Fuel Consumption with Hydrostatic Transmission*

- High performance SAA4D107E-1 engine
- Low fuel consumption
- Electronically-controlled HST with variable shift control system
- Variable traction control system
- S-mode

## *Excellent Operator Environment*

- HST traction control switch
- Electronically controlled directional lever
- Tilttable steering column
- Low-noise designed cab
- Pillar-less large ROPS/FOPS Level 2 cab-integrated
- Easy entry/exit, rear-hinged doors



## **KOMTRAX**<sup>®</sup>

KOMTRAX equipped machines can send location, SMR and operation maps to a secure website utilizing wireless technology. Machines also relay error codes, cautions, maintenance items, fuel levels, and much more.

## *Environmentally Friendly*

- EPA Tier 3 and EU Stage 3A emissions certified
- Low exterior noise
- Low fuel consumption

## ***Increased Reliability***

- Reliable Komatsu designed and manufactured components
- Sturdy main frame
- Adjustment-free, fully hydraulic, wet disc service and parking brakes
- Hydraulic hoses use flat face O-ring seals
- Cathion electrodeposition process is used to apply primer paint
- Powder coating process is used to apply main structure paint
- Sealed DT connectors for electrical connections

**NET HORSEPOWER**  
94 kW 126 HP @ 2000 rpm

**OPERATING WEIGHT**  
10505 - 10765 kg  
**23,160 - 23,733 lb**

**BUCKET CAPACITY**  
1.7 - 2.4 m<sup>3</sup>  
**2.2 - 3.1 yd<sup>3</sup>**



Photo may include optional equipment.

## ***Easy Maintenance***

- Equipment Management Monitoring System (EMMS)
- Easy access, gull-wing type engine side doors
- Automatic Reversible Fan
- KOMTRAX®

## HIGH PRODUCTIVITY AND LOW FUEL CONSUMPTION



### High Performance SAA4D107E-1 Engine

Electronic Heavy Duty Common Rail fuel injection system provides optimum combustion of fuel. This system also provides quick throttle response to match the machine's powerful tractive effort and quick hydraulic response.

**Net: 94 kW 126 HP**

### Low Emission Engine

This engine is EPA Tier 3 and EU Stage 3A emissions certified, without sacrificing power or machine productivity.

### Low Fuel Consumption

The high-torque engine and Hydrostatic Transmission (HST) with maximum efficiency in the low-speed range provide low fuel consumption.

### Eco Indicator

The eco indicator will help an operator to achieve energy savings.



## Hydrostatic Transmission (HST)

### Electronically-Controlled HST Using a 1-Pump, 2-Motor System

- The 1-pump, 2-motor system allows high-efficiency and high tractive effort. Engine power is transmitted hydraulically to a transfer case, then mechanically out to the differentials and out to the four driving wheels.
- HST provides quick travel response and aggressive drive into the pile. The variable displacement system automatically adjusts to the tractive effort demand to provide maximum power and efficiency.
- Full auto-shifting eliminates any gear shifting and kick-down operation to allow the operator to concentrate on digging and loading.
- When high drive torque is needed for digging, climbing, or initiating movement, the pump feeds both motors. This combination makes the loader very aggressive and quick.
- Under deceleration, the HST system acts as a dynamic brake on the mechanical drive system. The dynamic brake can hold the loader in position on most workable slopes. This can be an advantage in stockpiling and ramp loading.
- As the machine moves and gains ground speed, the torque demand decreases and the low speed motor is effectively removed from the drive system by a clutch. At this point, the flow is going to the high-speed motor and the low-speed motor is not causing drag on the system.
- An inching pedal gives the operator excellent simultaneous control of his travel and equipment hydraulic speeds. By depressing the inching pedal, drive pump flow to the motors will decrease, reducing ground speed and allowing the operator to use his accelerator to increase flow to his equipment hydraulics. Depressing the inching pedal further will activate the service brakes.

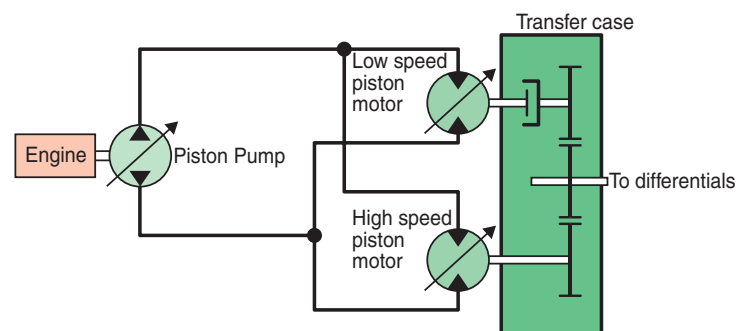



### Electronically-Controlled HST with Variable Shift Control System

The operator can choose between first, second, third, or fourth maximum speeds by dialing the speed range selector switch. For V-cycles, the operator can set the speed control switch to 1 or 2, which provides aggressive digging, quick response, and fast hydraulics. For load and carry, select 3 or 4 which still provides aggressive digging but with much faster travel speed.

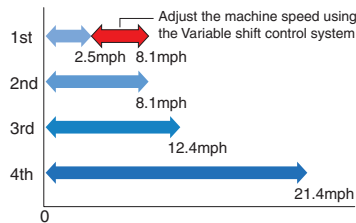

The variable shift switch allows the operator to adjust machine speed in applications such as confined V-loading. When in 1, the operator can adjust travel speed using the variable shift switch to match machine speed and hydraulics to the distance travelled. This feature is also useful when powering a broom or snowblower.

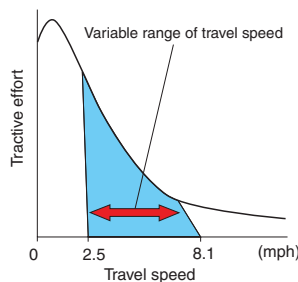

### Variable Traction Control System

The tractive effort of the machine, when traveling at a low speed, can be reduced by using the traction control switch. Combined with torque proportioning differentials, or optional limited slip differentials this system provides the following benefits.

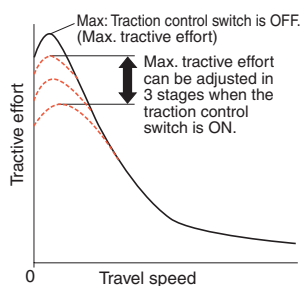

- Facilitates operation on soft ground where the tires of the machine are apt to slip.
- Eliminates excessive bucket penetration and reduces tire slippage during stockpile loading to improve the work efficiency.
- Reduces tire slippage to extend the life of tires.



Furthermore, the maximum tractive effort can be adjusted in three stages (one stage for conventional machines) when the traction control switch is ON. This allows the operator to select the optimum tractive effort for diversified road

### S-mode

Setting the switch to S-mode provides optimum driving force for operations on slippery road surfaces, like snow-removal on snow-covered surfaces, resulting in reduced tire slippage and facilitation of the operation.

Unexpected tire slippage on slippery road surfaces is suppressed by controlling the engine speed and HST motor when traveling at a low speed. (S-mode is effective only in forward

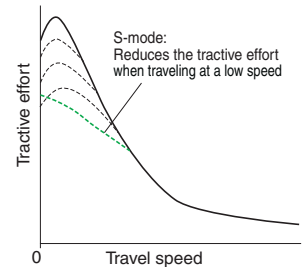

### Max. Traction Switch

Max. traction switch is located on the work equipment control lever. When the traction control switch is at the ON position or S-mode is selected, pushing this switch cancels the setting of the traction control temporarily and increases the tractive effort to its 100% value. Then pushing the max. traction switch again or operating the F/R lever returns the tractive effort to the set value automatically. This switch is useful for operations such as stockpile work where large tractive effort is required temporarily.

### Accelerator Pedal Sensitive HST Control

Finely-tuned HST control according to the accelerator pedal angle reduces shocks and allows smoother traveling and better energy-saving operation.



### Maximum Dumping Clearance and Reach

The long lift arms provide high dumping clearances and maximum dumping reach. The operator can even level loads on the body of a dump truck easily and efficiently.

**Dumping Clearance:** 2830 mm 9'3"  
**Dumping Reach:** 930 mm 3'1"  
 (2.0 m<sup>3</sup> 2.6 yd<sup>3</sup> bucket with B.O.C.E.)

## INCREASED RELIABILITY

### Komatsu Components

Komatsu manufactures the engine, transfer case, axles, and hydraulic components on this wheel loader.

Komatsu loaders are manufactured with an integrated production system under a strict quality control system.

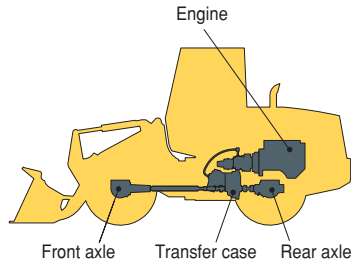

### Wet Multi-disc Brakes and Fully Hydraulic Braking System

This means lower maintenance costs and higher reliability. Wet disc brakes are fully sealed. Contaminants are kept out, reducing wear and resulting maintenance. Brakes require no adjustments for wear, meaning even lower maintenance. The new parking brake is also an adjustment-free, wet multi-disc for high reliability and long life. Added reliability is designed into the braking system by the use of two independent hydraulic circuits, providing hydraulic backup should one of the circuits fail. Fully hydraulic brakes mean no air system to bleed and no condensation of water in the system that can lead to contamination, corrosion, and freezing.

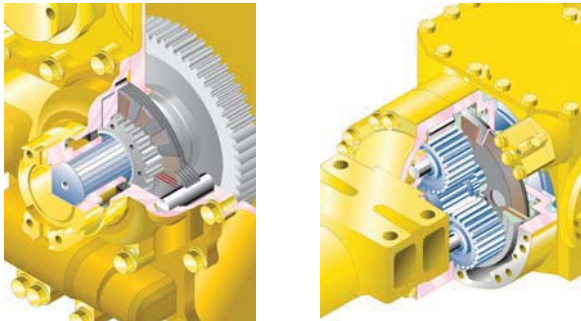

### Overrun Reduction System

When the machine descends a slope of six degrees or less, maximum travel speed is automatically restricted to approximately 38 km/h **23 mph**, for protection against damage of power train components and brakes, by sensing the travel speed and controlling the discharge amount of the HST pump and motor. When the machine descends a steep slope and the travel speed reaches 36 km/h **22 mph**, the caution lamp lights up to inform the operator to reduce the travel speed.

Note: When the machine descends a steep slope, the use of the service brake is necessary to limit travel speed.

### High-rigidity Frames and Loader Linkage

The front and rear frames and the loader linkage have more torsional rigidity to provide increased resistance to stresses. The frames and loader linkage are designed to accommodate actual working loads, and simulated computer testing proves their strength.

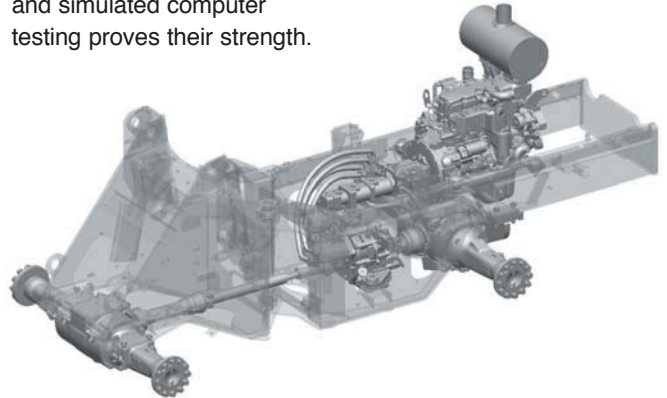

### Flat Face-to-Face O-Ring Seals

Flat face-to-face O-ring seals are used to securely seal hydraulic hose connections.

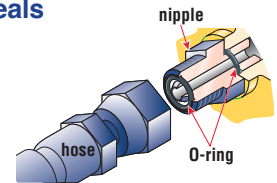

### Cathion Electrodeposition Primer Paint/ Powder Coating Final Paint

Cathion electrodeposition paint is applied as a primer paint and powder coating is applied as topcoat to the exterior metal sheet parts. Some external parts are made of plastic providing long life and high impact resistance.

### Sealed DT Connectors

Main harnesses and controller connectors are equipped with sealed DT connectors providing high reliability, water resistance, and dust resistance.



# EASY MAINTENANCE



Photo may include optional equipment.

## Equipment Management Monitoring System (EMMS)

Monitor is mounted in front of the operator for easy viewing, allowing the operator to easily check gauges and warning lights.



A specially designed two-spoke steering wheel allows the operator to easily see the instrument panel.

## Maintenance Control and Troubleshooting Functions

- **Action code display function:** If an abnormality occurs, the monitor displays action details on the character display at the center bottom of the monitor.
- **Monitor function:** Controller monitors engine oil pressure, coolant temperature, air cleaner clogging, etc. If the controller finds abnormalities, the error is displayed on the LCD.
- **Replacement time notice function:** Monitor informs replacement time of oil and filters on the LCD when replacement intervals are reached.
- **Trouble data memory function:** Monitor stores abnormalities for effective troubleshooting.

## Gull-wing Type Engine Side Doors Open Wide

The operator can open and close each gull-wing type engine side door easily, with the assistance of a gas spring, to perform daily service checks from the ground.



## Ease of Radiator Cleaning

If the machine is operating in adverse conditions, the operator can reverse the hydraulic cooling fan from inside the cab by pressing a switch on the control panel.

## Automatic Reversible Fan

The engine fan is driven hydraulically and can be operated in reverse automatically. When the switch is in the automatic position, the fan revolves in reverse



- B:** Manual Reverse Mode
- A:** Normal Rotation Mode
- C:** Auto Reverse Mode



## OPERATOR ENVIRONMENT

### Easy Operation

#### Electronically Controlled Directional Lever

The operator can change direction with the touch of a finger without removing their hand from the steering wheel. Solid state electronics makes this possible.



#### Tiltable Steering Column

The operator can tilt the steering column to provide a comfortable working position.



#### Multi-function Loader Control Lever with Forward & Reverse Switch

A new multi-function control lever integrated with forward and reverse switch allows the operator to easily operate the work equipment, to reduce operator fatigue and to increase controllability. The adjustable wrist rest provides the operator with a variety of comfortable operating positions.



#### Right-side Control Panel

The operator can select the speed range, maximum travel speed in 1st, tractive effort, and reversible fan setting.



- 1: Speed range selector switch
- 2: Variable shift switch
- 3: Traction control switch

- 4: Max. traction switch
- 5: Fan reverse switch





## Comfortable Operation

### Low-noise Design

Noise level at operator's ear: 70 dB(A)  
Dynamic noise level (outside): 104 dB(A)

The large cab is mounted with Komatsu's unique ROPS/FOPS viscous mounts. The low-noise engine, hydraulically driven fan, and hydraulic pumps are mounted with rubber cushions, and the cab sealing is improved to provide a quiet, low-vibration, pressurized, and comfortable operating environment.

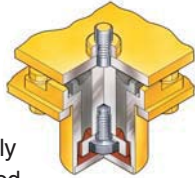

### Pillar-less Large Cab

A wide pillar-less flat glass provides excellent front visibility. The wiper arm covers a large area to provide great visibility even on rainy days. The large cab area provides maximum space

for the operator. The front mounted air conditioner was introduced to increase seat reclining and backward slide adjustment.

### Rear-hinged Full Open Cab Doors

The large cab doors are rear-hinged to open fully, offering easy entry/exit. Exit from the cab is easily accomplished by having steps in view of the operator. Sloped hand rails help guide the foot on to the first step.



Photos may include optional equipment.

# WA200-6 WHEEL LOADER

## SPECIFICATIONS



### ENGINE

Model .....Komatsu SAA4D107E-1  
 Type .....Water-cooled, 4-cycle  
 Aspiration .....Turbocharged, aftercooled  
 Number of cylinders ..... 4  
 Bore x stroke ..... 107 mm x 124 mm **4.21" x 4.88"**  
 Piston displacement ..... 4.46 ltr **272 in<sup>3</sup>**  
 Governor ..... All-speed, electronic  
 Horsepower  
 SAE J1995 .....Gross 95.2 kW **128 HP**  
 ISO 9249/SAE J1349 .....Net 94 kW **126 HP**  
 Hydraulic fan at maximum speed .....Net 91 kW **122 HP**  
 Rated rpm ..... 2000 rpm  
 Fan drive method for radiator cooling .....Hydraulic  
 Fuel system .....Direct injection  
 Lubrication system:  
 Method .....Gear pump, force-lubrication  
 Filter ..... Full-flow type  
 Air cleaner .....Dry type with double elements and  
 dust evacuator, plus dust indicator  
 EPA Tier 3 and EU Stage 3A emissions certified.



### TRANSMISSION

Type .....Hydrostatic, 1 pump, 2 motors with speed range select  
 Travel speed: km/h **mph**  
 Measured with 17.5-25 tires

	1st	2nd	3rd	4th
Both Forward and Reverse	4.0 - 13.0 <b>2.5 - 8.1</b>	13.0 <b>8.1</b>	20.0 <b>12.4</b>	34.5 <b>21.4</b>

Measured with 20.5-25 tires

	1st	2nd	3rd	4th
Both Forward and Reverse	4.4 - 14.3 <b>2.7 - 8.9</b>	14.3 <b>8.9</b>	22.0 <b>13.7</b>	38.0 <b>23.6</b>



### AXLES AND FINAL DRIVES

Drive system .....Four-wheel drive  
 Front .....Fixed, semi-floating  
 Rear .....Center-pin support, semi-floating,  
 24° total oscillation  
 Reduction gear .....Spiral bevel gear  
 Differential gear .....Torque proportioning  
 Final reduction gear .....Planetary gear, single reduction



### BRAKES

Service brakes .....Hydraulically actuated,  
 wet disc brakes actuate on four wheels  
 Parking brake .....Wet, multi-disc brake on transfer output shaft  
 Emergency brake .....Parking brake is commonly used



### STEERING SYSTEM

Type .....Full-hydraulic power steering  
 Steering angle ..... 38° each direction (40° end stop)  
 Minimum turning radius at  
 the center of outside tire ..... 5100 mm **16'9"**



### HYDRAULIC SYSTEM

Steering system:  
 Hydraulic pump .....Gear type pump  
 Capacity ..... 85 ltr/min **22.5 U.S. gal/min** at rated rpm  
 Relief valve setting ..... 20.6 MPa 190 kgf/cm<sup>2</sup> **3,000 psi**  
 Hydraulic cylinders:  
 Type .....Double-acting, piston type  
 Number of cylinders ..... 2  
 Bore x stroke ..... 70 mm x 453 mm **2.8" x 17.8"**  
 Loader control:  
 Hydraulic pump .....Gear type pump  
 Capacity ..... 54 ltr/min **14.3 U.S. gal/min**  
 Relief valve setting ..... 20.6 MPa 210 kgf/cm<sup>2</sup> **3,000 psi**  
 Hydraulic cylinders:  
 Type .....Double-acting, piston type  
 Number of cylinders—bore x stroke:  
 Boom cylinder ..... 2- 120 mm x 673.5 mm **4.7" x 26.5"**  
 Bucket cylinder ..... 1- 130 mm x 493 mm **5.1" x 19.4"**  
 Control valve ..... 2-spool type  
 Control positions:  
 Boom .....Raise, hold, lower, and float  
 Bucket .....Tilt-back, hold, and dump  
 Hydraulic cycle time (rated load in bucket)  
 Raise ..... 5.9 sec  
 Dump ..... 1.4 sec  
 Lower (Empty) ..... 3.6 sec



### SERVICE REFILL CAPACITIES

Cooling system ..... 17 ltr **4.5 U.S. gal**  
 Fuel tank ..... 177 ltr **46.8 U.S. gal**  
 Engine ..... 15.5 ltr **4.1 U.S. gal**  
 Hydraulic system ..... 58 ltr **15.3 U.S. gal**  
 Axle (each front and rear) ..... 18 ltr **4.8 U.S. gal**  
 Transfer case ..... 5 ltr **1.3 U.S. gal**



### BUCKET SELECTION GUIDE

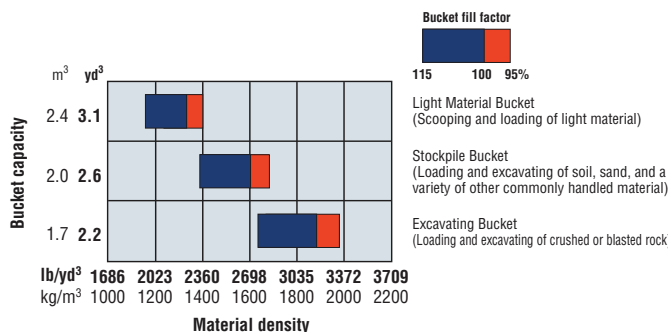



DIMENSIONS

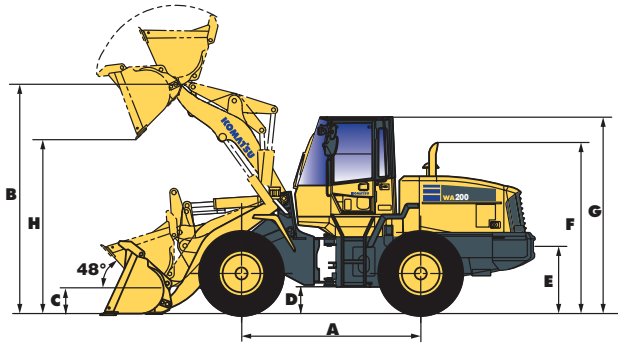

		17.5-25 tires		20.5-25 tires	
Tread		1930 mm	6'4"	1930 mm	6'4"
Width over tires		2375 mm	7'10"	2470 mm	8'1"
A Wheelbase		2840 mm	9'4"	2840 mm	9'4"
B Hinge pin height, at max. height	Standard Boom	3635 mm	11'11"	3705 mm	12'2"
	High Lift Boom	4225 mm	13'10"	4295 mm	14'1"
C Hinge pin height, at carry position	Standard Boom	410 mm	1'4"	380 mm	1'3"
	High Lift Boom	600 mm	2'0"	570 mm	1'10"
D Ground clearance		425 mm	1'5"	495 mm	1'8"
E Hitch height		870 mm	2'10"	940 mm	3'1"
F Overall height, top of the stack		2725 mm	8'11"	2795 mm	9'2"
G Overall height, ROPS cab		3110 mm	10'2"	3180 mm	10'5"

Measured with 20.5-25-12PR (L3) tires, ROPS/FOPS cab

	Stockpile Bucket	Excavating Bucket	Light Material Bucket	High Lift Boom
				Excavating Bucket
	Bolt-On Cutting Edges	Bolt-On Cutting Edges	Bolt-On Cutting Edges	Bolt-On Cutting Edges
Bucket capacity: heaped	2.0 m <sup>3</sup>	1.7 m <sup>3</sup>	2.4 m <sup>3</sup>	1.7 m <sup>3</sup>
	<b>2.6 yd<sup>3</sup></b>	<b>2.2 yd<sup>3</sup></b>	<b>3.1 yd<sup>3</sup></b>	<b>2.2 yd<sup>3</sup></b>
struck	1.7 m <sup>3</sup>	1.4 m <sup>3</sup>	2.0 m <sup>3</sup>	1.4 m <sup>3</sup>
	<b>2.2 yd<sup>3</sup></b>	<b>1.8 yd<sup>3</sup></b>	<b>2.6 yd<sup>3</sup></b>	<b>1.8 yd<sup>3</sup></b>
Bucket width	2550 mm 8'4"	2550 mm 8'4"	2550 mm 8'4"	2550 mm 8'4"
Bucket weight	785 kg 1,731 lb	740 kg 1,631 lb	875 kg 1,929 lb	740 kg 1,631 lb
Dumping clearance, max. height and 45° dump angle*	2830 mm 9'3"	2885 mm 9'6"	2725 mm 8'11"	3480 mm 11'5"
Reach at max. height and 45° dump angle *	930 mm 3'1"	875 mm 2'10"	1035 mm 3'5"	970 mm 3'2"
Reach at 2130 mm 7' clearance and 45° dump angle*	1410 mm 4'8"	1385 mm 4'7"	1460 mm 4'9"	1955 mm 6'4"
Reach with arm horizontal and bucket level*	2145 mm 7'0"	2065 mm 6'9"	2295 mm 7'6"	2580 mm 8'5"
Operating height (fully raised)	4955 mm 16'3"	4835 mm 15'10"	5065 mm 16'7"	5430 mm 17'9"
Overall length	6895 mm 22'7"	6815 mm 22'4"	7050 mm 23'2"	7485 mm 24'7"
Loader clearance circle (bucket at carry, outside corner of bucket)	11700 mm 38'5"	11660 mm 38'3"	11780 mm 38'8"	11840 mm 38'10"
Digging depth: 0°	65 mm 2.6"	65 mm 2.6"	65 mm 2.6"	200 mm 7.9"
	10°	250 mm 9.8"	235 mm 9.3"	275 mm 10.8"
Static tipping load: straight	9690 kg 21,363 lb	9750 kg 21,495 lb	9540 kg 21,032 lb	9270 kg 20,437 lb
	40° full turn	8345 kg 18,397 lb	8405 kg 18,530 lb	8195 kg 18,067 lb
Breakout force	93.2 kN 9500 kgf	102.5 kN 10450 kgf	81.4 kN 8300 kgf	93.6 kN 9545 kgf
	<b>20,944 lb</b>	<b>23,038 lb</b>	<b>18,298 lb</b>	<b>21,043 lb</b>
Operating weight	10550 kg 23,259 lb	10505 kg 23,160 lb	10640 kg 23,457 lb	10765 kg 23,733 lb

\* At the end of B.O.C.E.

All dimensions, weights, and performance values based on SAE J732c and J742b standards.

Static tipping load and operating weight shown include lubricant, coolant, full fuel tank, ROPS cab, and operator. Machine stability and operating weight affected by counterweight, tire size, and other attachments.

Apply the following weight changes to operating weight and static tipping load.



## WEIGHT AND DIMENSION CHANGES

	Change in Operating Weight		Change in Tipping Load				Change in Vertical Dimensions		Change in Reach	
			Straight		Full Turn					
17.5-25-12PR (L2)	-585 kg	<b>-1290 lb</b>	-445 kg	<b>-981 lb</b>	-390 kg	<b>-860 lb</b>	-70 mm	<b>-2.8"</b>	70 mm	<b>2.8"</b>
17.5-25-12PR (L3)	-480 kg	<b>-1058 lb</b>	-365 kg	<b>-805 lb</b>	-320 kg	<b>-705 lb</b>	-70 mm	<b>-2.8"</b>	70 mm	<b>2.8"</b>
20.5-25-12PR (L2)	-185 kg	<b>-408 lb</b>	-140 kg	<b>-309 lb</b>	-120 kg	<b>-265 lb</b>	0 mm	<b>0"</b>	0 mm	<b>0"</b>
Install ROPS canopy (instead of cab)	-150 kg	<b>-331 lb</b>	-150 kg	<b>-331 lb</b>	-130 kg	<b>-287 lb</b>				



## STANDARD EQUIPMENT

- 2-spool valve for boom and bucket controls
- Air conditioner
- Alternator, 60 A
- Auto shift transmission with mode select system
- Back-up alarm
- Back-up lamp
- Batteries, 110 Ah/2 x 12 V
- Boom kick-out
- Bucket positioner
- Counterweight, standard and additional (300 kg **661 lb**)
- Deluxe suspension seat
- Directional signal
- Engine, Komatsu SAA4D107E-1 diesel
- Engine shut-off system, electric
- Floor mat
- Fuel pre-filter with water separator
- Hydraulic-driven fan with auto-reverse rotation
- KOMTRAX®
- Lift cylinders and bucket cylinder
- Loader linkage with standard lift arm
- Main monitor panel with Equipment Management Monitoring System (EMMS)
- Mono-lever loader control with transmission F/R switch
- Radiator mask, lattice type
- Rear defroster (electric)
- Rear view mirrors, inside (2), outside (3)
- Rear window washer and wiper
- Rims for 20.5-25 tires
- ROPS/FOPS Level 2 cab
- Seat belt, 76 mm **3"** retractable
- Service brakes, wet disc type
- Starting motor, 4.5 kW/24 V
- Steering wheel, tiltable
- Sun visor
- Transmission speed ranges, 4 forward and 4 reverse



## OPTIONAL EQUIPMENT

- 3-spool valve
- AM/FM stereo radio cassette
- Auxiliary steering (SAE)
- Cutting edge (bolt-on type)
- Electronically Controlled Suspension System (ECSS)
- Engine pre-cleaner with extension
- High lift boom arrangement
- JRB bucket, general purpose, for use with coupler, with BOCE 1.9 m<sup>3</sup> **2.5 yd<sup>3</sup>**
- JRB bucket, general purpose, for use with coupler, with BOCE 2.1 m<sup>3</sup> **2.75 yd<sup>3</sup>**
- JRB construction forks, for use with coupler, 1219 mm **48"**
- JRB extendable boom, for use with coupler, 3-section
- JRB hydraulic quick coupler
- Limited slip differential (F&R)
- Rear full fenders
- Rims for 17.5-25 tires
- Wide core radiator

AESS755-01

©2008 Komatsu America Corp.

Printed in USA

D6(5M)C

06/08 (EV-1)

# KOMATSU®