

KOMATSU®

WA470-7

Tier 4 Interim Engine

WA470

NET HORSEPOWER

272 HP @ 2000 rpm
203 kW @ 2000 rpm

OPERATING WEIGHT

52,007–52,426 lb
23,590–23,780 kg

BUCKET CAPACITY

5.0–5.75 yd³
3.8–4.4 m³



PHOTOS MAY INCLUDE OPTIONAL EQUIPMENT

WA470

WALK-AROUND

WA470-7



Photos may include optional equipment

WA470-7

Tier 4 Interim Engine

NET HORSEPOWER
272 HP @ 2000 rpm
203 kW @ 2000 rpm

OPERATING WEIGHT
52,007–52,426 lb
23,590–23,780 kg

BUCKET CAPACITY
5.0–5.75 yd³
3.8–4.4 m³



HIGH PRODUCTION WITH LOW FUEL CONSUMPTION

Large capacity torque converter with lock-up:

- 8% lower fuel consumption
- Faster top speed
- Quick acceleration
- Lock-up in 2nd, 3rd and 4th gear

Komatsu SmartLoader Logic helps reduce fuel consumption with no decrease in production.

A powerful **Komatsu SAA6D125E-6 engine** provides a net output of 203 kW **272 HP** with 8% improved fuel consumption. This engine is EPA Tier 4 Interim and EU stage 3B emissions certified.

Komatsu Variable Geometry Turbocharger (KVG T) uses a hydraulic actuator to provide optimum air flow under all speed and load conditions.

Komatsu Diesel Particulate Filter (KDPF) captures 90% of particulate matter and provides automatic regeneration that does not interfere with daily operation.

Increased cooling capacity

- Auto-reversing fan is standard
- Wider core coolers
- Swing out fan

An all new **cab** provides the operator with improved comfort and visibility.

New high resolution monitor panel

- Enhanced and intuitive on-board diagnostics
- Integrated with KOMTRAX Level 4
- Integrated with Komatsu Tier 4 technology

Rearview monitoring system (standard)

New high capacity air suspension seat

- Seat mounted EPC controls with F-N-R switch
- Seat heater is standard

Energy saving guidance

- Six operator guiding messages
- Enhanced eco-gauge

Komatsu Auto Idle Shutdown helps reduce idle time and reduce operating costs.



Remote boom and bucket positioners can set kick-outs from inside the cab.

Variable displacement piston pumps with CLSS help reduce fuel consumption.

KOMTRAX®

Komtrax equipped machines can send location, SMR and operation maps to a secure website utilizing wireless technology. Machines also relay error codes, cautions, maintenance items, fuel levels, and much more.

HIGH PRODUCTIVITY & LOW FUEL CONSUMPTION

WA470-7

High Performance Komatsu SAA6D125E-6 Engine

The Komatsu SAA6D125E-6 engine is EPA Tier 4 Interim and EU Stage 3B emissions certified and provides exceptional performance while reducing fuel consumption. Based on Komatsu proprietary technologies developed over many years, this new diesel engine reduces exhaust gas particulate matter (PM) by more than 90% and nitrogen oxides (NOx) by more than 45% when compared to Tier 3 levels.

Through the in-house development and production of engines, electronics, and hydraulic components, Komatsu has achieved great advancements in technology, providing high levels of performance and efficiency in virtually all applications. The operator will notice high torque at low speeds, excellent operation and low fuel consumption to provide maximum productivity.



Komatsu Diesel Particulate Filter (KDPF)

Komatsu has developed a high efficiency diesel particulate filter that captures more than 90% of particulate matter. Both passive and active regeneration are automatically initiated by the engine controller depending on the soot level of the KDPF. A special oxidation catalyst with a fuel injection system is used to oxidize and remove particulate matter while the machine is running so the regeneration process will not interfere with daily operation.

The operator can also initiate regeneration manually or disable regeneration depending on the work environment.

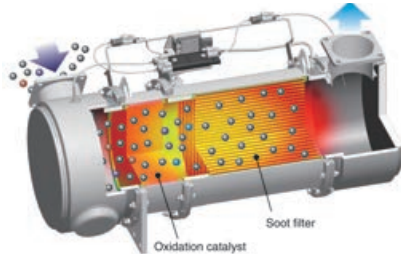

Closed Crankcase Ventilation (CCV)

Crankcase emissions (blow-by gas) are passed through a CCV filter. The CCV filter traps oil mist which is returned back to the crankcase while the gas, which is almost oil mist free, is fed back to the air intake.



Heavy Duty High Pressure Common Rail (HPCR) Fuel Injection System

The heavy duty HPCR system is electronically controlled to deliver a precise quantity of pressurized fuel into the combustion chamber using multiple injection events to achieve complete fuel burn and reduce exhaust gas emissions. Fuel injector reliability has been improved by using ultra-hard wear resistant materials.

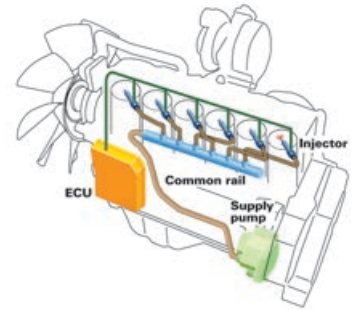

Komatsu Variable Geometry Turbocharger (KVTG)

Using Komatsu proprietary technology, a newly designed variable geometry turbocharger with a hydraulic actuator is used to manage and deliver optimum air flow to the combustion chamber under all speed and load conditions. The robust hydraulic actuator provides power and precision, resulting in cleaner exhaust gas, quick acceleration and improved fuel economy while maintaining performance.

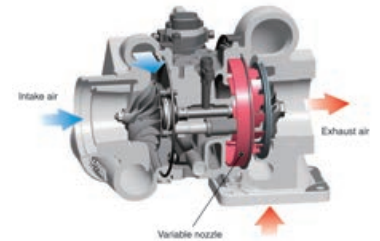

Redesigned Combustion Chamber

The combustion chamber located at the top of the engine piston has a new shape designed to improve combustion and further reduce NOx, PM, fuel consumption, and noise levels.

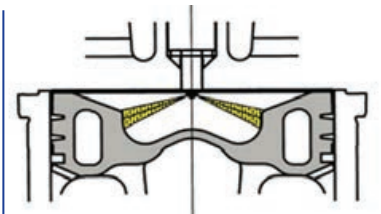

Cooled Exhaust Gas Recirculation (EGR)

Cooled EGR, a technology that has been well proven in Komatsu Tier 3 engines, reduces NOx emissions to meet Tier 4 levels. The hydraulically actuated EGR system has increased capacity and uses larger and more robust components to ensure reliability for demanding work conditions.

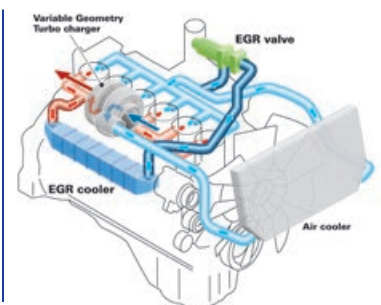

Advanced Electronic Control System

The engine control system has been upgraded to effectively manage the air flow rate, EGR gas flow rate, fuel injection parameters, and aftertreatment functions. The new control system also provides enhanced diagnostic capabilities.

Komatsu SmartLoader Logic

The WA470-7 provides Komatsu SmartLoader Logic, a new engine control system. This technology acquires data from various sensors in the vehicle and controls the engine to yield enough torque for each work phase. Engine torque requirements for a wheel loader vary depending on working conditions. For example, the loader requires higher torque for digging in V-shape loading, but less torque when traveling with an empty bucket. This technology limits the engine torque during less demanding work, therefore saving fuel. Komatsu SmartLoader Logic functions automatically and doesn't interfere with operation, saving fuel without decreasing production.

Large-Capacity Torque Converter

The newly designed power train has a large capacity torque converter for optimum efficiency. The WA470-7 has greater productivity in V-shape loading applications because the increased tractive effort does not require full throttle. The improved hill climbing ability allows the WA470-7 to up-shift gears faster because of improved acceleration. The WA470-7 can achieve higher gear ranges and maintain higher travel speed when working in load-and-carry applications. In most applications, production is increased and fuel consumption is reduced, resulting in improved fuel efficiency.

Enhanced Lock-Up

The newly designed large-capacity torque converter with lock-up is standard on the WA470-7. The lock-up function activates in 2nd, 3rd and 4th gears to give the loader a maximum travel speed of 38.3 km/h **23.8 mph**. The large capacity torque converter with enhanced lock-up is effective for both load and carry applications, and V-shape loading which uses lower gears. The enhanced lock-up reduces the clutch engagement shock by controlling engine torque with Komatsu SmartLoader Logic improving operator comfort. The enhanced lock-up combined with Komatsu SmartLoader Logic results in lower fuel consumption and higher travel speeds in load and carry and even some cycle loading applications.

Komatsu Auto Idle Shutdown

In order to reduce idle time, Komatsu offers Komatsu Auto Idle Shutdown. This function will shut the engine off and apply the parking brake and hydraulic lock after a preset idle time limit. This time limit can be set by the operator or service technician and may range from 3 minutes to 60 minutes.

Low Fuel Consumption

Komatsu added many new features on the WA470-7 to reduce fuel consumption. These features enable further fuel efficiency by optimally controlling engine power and matching the Komatsu designed and produced high efficiency power train components and hydraulic system.

8% Reduction in Fuel consumption

* Compared with the WA470-6, fuel consumption varies depending on working conditions.

Dual-Mode Engine Power Select System

This wheel loader offers two selectable operating modes—E and P.

- **E Mode:** This mode provides maximum fuel efficiency for general loading.
- **P Mode:** This mode provides maximum power output for hard digging operations or hill climb applications.



Dual mode engine power selection switch

Eco-Guidance

The Eco-guidance provides information on the monitor to help save fuel. The monitor displays messages in real-time during operation and on the exit screen when turning the key to shut off the engine. This function can be controlled through the monitor. The operator can view Eco-guide and fuel consumption through the monitor as well as through KOMTRAX.

During operation



User menu for ON/OFF setting



Key OFF

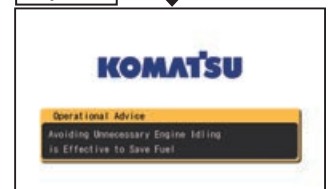

Variable Displacement Piston Pump & CLSS

The variable displacement piston pump combined with the Closed-center Load Sensing System (CLSS) delivers as much hydraulic flow as the job requires, preventing wasted hydraulic flow. Minimized loss contributes to better fuel economy.

New Designed Cabin

The new cabin offers better ergonomics, more storage space and more features to improve operator comfort.



WA470-7

Operator Seat with EPC (Electronic Pilot Control) Levers

The work equipment control system has an EPC lever console integrated into the higher capacity seat and moves with the seat. The angle of the armrest is fully adjustable for optimum operator comfort. An F-N-R switch is now incorporated in dual and three lever configurations as well as the optional monolever configurations. A heated seat is now standard.



Tiltable / Telescopic Steering Wheel

The WA470-7 comes standard with a tiltable and telescopic steering wheel that can be pushed up and out of the way for easy entry and exit of the cab.



Low Noise Design

Operator's ear noise level : 72 dB(A)

Dynamic noise level (outside): 112 dB(A)

The large cab is mounted with Komatsu's unique ROPS/FOPS viscous mounts. The low-noise engine, hydraulically driven fan, and hydraulic pumps are mounted with rubber cushions, and the cab sealing is designed to provide a quiet, low-vibration, dustproof, and comfortable operating environment.



Increased Cab Storage Area

The WA470-7 cab features a storage box on the left hand side of the cab to allow the operator to store items out of the way. A hot or cold box on the right hand side of the cab allows the operator to keep a beverage or lunch warm or cold, depending on the season.



Ergonomic Comfort

The dashboard and cab have been redesigned to improve operator comfort. The monitor can be controlled by the multi-switch panel. Also, the front glass of the cab has been lowered to improve visibility.



Rear View Monitoring System (standard)

The operator can view the rear of the machine with a full color monitor that is located on the right side of the cab. This monitor can be always on or only on when the loader goes into reverse. Visual guidelines can also be added for more convenience.



Seat Belt Caution Indicator

A warning indicator on the monitor appears when the seat belt is not engaged.



Engine Shutdown Secondary Switch

The engine stop switch is incorporated to allow shutdown of the machine when accessing the key switch is not possible.

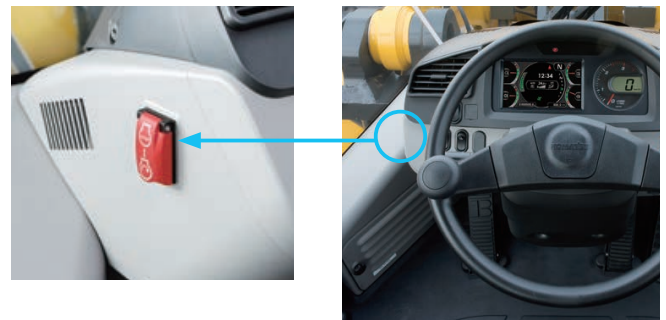

Auxiliary Input (MP3 Jack) 12 V Outlets

An Aux input to allow use of an MP3 player or other device is now standard as well as two 12 volt outlets. These are all located on the front of the right hand console.

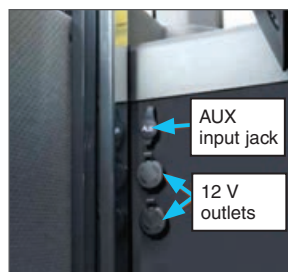



Easy Entry and Egress

The WA470-7 has an inclined ladder with wide steps and hand holds to ease entry and exit from the cab. The door latch can be reached from ground level to ease opening and closing the door.

Remote Bucket & Boom Positioner

The operator can set the bucket angle and remote boom positioner from the cab. Both upper and lower boom positions are adjustable in the cab with the push of a button. The bucket positioner can memorize three horizontal settings, allowing the operator to easily change attachments without having to reset the bucket position. In each horizontal setting, the operator can adjust the setting with the switch in the cab. This can help save the operator time when changing attachments.



Remote positioner switch
Boom / Bucket

Automatic Kick-down

The WA470-7 has the ability to automatically shift down to F1. This can be activated through the monitor.

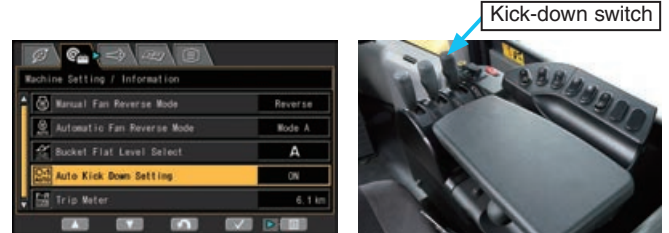

Electronically Controlled Suspension System (ECSS)

The Electronically Controlled Suspension System (ECSS) or ride control system uses an accumulator which absorbs some of the shock in the boom arm, giving the operator a much smoother ride. This reduces operator fatigue and reduces material spillage during load and carry operations. ECSS is speed sensitive, meaning that the boom won't move during stationary digging. ECSS is standard on the WA470-7.

New Mono Lever With Integrated 3rd Spool Control (option)

The mono lever option has been redesigned for better ergonomics. When equipped with the optional 3rd spool valve, it allows the operator to control the 3rd spool with your thumb providing greatly improved operator comfort. The 3rd spool valve can be operated in either continuous or proportional flow modes. The mono lever also includes a F-N-R switch.

INFORMATION & COMMUNICATION TECHNOLOGY

Large High Resolution Monitor Panel

A new large, user-friendly machine monitor display various machine information and allows for various settings of the machine. The LCD monitor is a 7-inch color TFT-LCD and displays maintenance information, operational records, ECO guidance record, etc.

The switch panel is used to select the various LCD unit screens and the air conditioner control screen. By using the switch panel, you can display various user menus on the screen and perform the settings of the machine.



Machine monitor

- | | |
|---------------------------|---|
| 1 LCD unit | 8 Engine coolant temperature gauge |
| 2 LED unit | 9 Hydraulic oil temperature gauge |
| 3 Engine tachometer | 10 Torque converter oil temperature gauge |
| 4 Speedometer | 11 Fuel gauge |
| 5 ECO gauge | 12 Message pilot lamp |
| 6 Air conditioner display | 13 Pilot lamps |
| 7 Shift indicator | |

Switch panel

- 1 Air conditioner switches / Numeral key pad 2 Function switches

Large LCD Monitor

The LCD monitor displays various information of the machine such as ECO Guidance, operation records, and maintenance information. Since the LCD unit has a wide full color display area, it displays more information and is easy to read. For example, the "Operation Records" menu displays various records of the actual working hours, average fuel consumption, idling hours, and E mode operation ratio, as well as other features. These records are displayed in the form of daily data and time period data. Data can be displayed in 25 languages to support operators around the world. The controls for the automatic air conditioner are integrated into the LCD monitor panel to allow the operator to easily and precisely set the cab atmosphere.

The monitor clearly displays abnormality codes to alert the operator. These codes are stored for trouble shooting. The monitor also provides for advanced monitoring of system parameters through the Service Mode to aid in troubleshooting and reduce downtime.

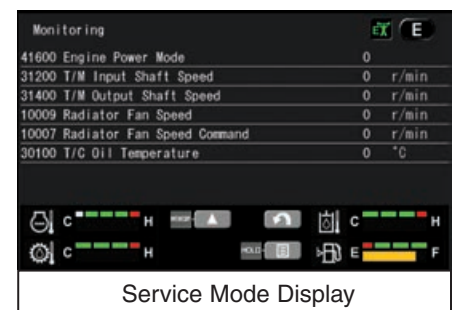
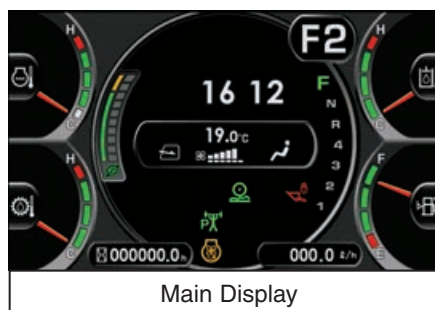



Photos may include optional equipment

Full Side-Opening Gull-Wing Engine Doors

The large gull-wing type engine doors are operated with low effort assisted by gas springs. The doors open in two steps. The first position is for daily maintenance and the second position is for periodic maintenance. Large steps are provided on each side of the frame to help access.



Photos may include optional equipment

Swing-out Type Cooling Fan

The cooling fan swings out for cleaning. The coolers feature wider spacing of the cooling fins to reduce clogging.



Photos may include optional equipment

Auto Reversing Fan

The engine cooling fan is driven hydraulically. It can be set to reverse automatically during operation. Fan reverse mode and timing can be controlled through the monitor.



Maintenance Function

The monitor informs the operator when the replacement interval for oil and filters will be reached.



Battery Disconnect

The battery disconnect is located in the right side of the engine. This can be used to disconnect power when performing service work on the machine.



Engine Compartment

The WA470-7 engine compartment was laid out for easy serviceability. Great attention was paid to the location of the maintenance items, such as the filters, dipsticks and oil fill locations. The same goes for the KDPF and CCV filter, as even the top of the hood was redesigned to ease removal of the KDPF for cleaning or replacement.



KDPF Regeneration

Soot trapped by and accumulated in the KDPF is removed by burning it periodically and automatically.

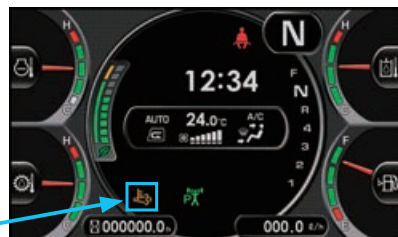

KDPF regeneration indicator

Manual Stationary Regeneration

Under most conditions, active regeneration will occur automatically with no effect on machine operation. In case the operator needs to disable active regeneration or initiate a manual stationary regeneration, this can be easily accomplished through the monitor panel.

A soot level indicator is displayed to show how much soot is trapped in the KDPF.



Rear Full Fenders (Option)

The WA470-7 has a new rear fender option. The plastic rear fenders now open outward, keeping the force to open the engine doors low, even when there is mud or snow on the fenders. The fenders swing far out of the way to give the technician easy access to the engine compartment. Mudflaps are also included on the rear fenders.

Cab Air Intake Filter

The cab air intake filter is located on the front of the cab, on the left hand side of the machine behind a lockable door, for easy access and security.



LED Taillights

LED brake lights and LED reverse lights provide long bulb life and use less power than the ones on the WA480-6.



KOMTRAX EQUIPMENT WORKING ENVIRONMENT MONITORING



KOMTRAX is Komatsu's remote equipment monitoring and management system. KOMTRAX gathers critical machine and operation information and provides it in a user-friendly format so that you can make well-informed decisions. KOMTRAX gives you more control of your equipment and better control of your business!

KOMTRAX comes standard on all new Komatsu machines with complimentary manufacturer communications services throughout the entire ownership period. It is a powerful tool and makes Komatsu machines an even better purchase!

Fleet Optimization

KOMTRAX tells you how your machines and operators are performing. KOMTRAX provides:

- Fuel consumption data and trends, by unit or fleet
- Machine fuel level
- Machine utilization
- Actual working hours/Machine idle hours
- Attachment usage hours
- Machine travel hours
- Machine load analysis
- Operating mode ratios

Location and Asset Management

KOMTRAX tells you where your machines are and can help prevent unauthorized use. KOMTRAX provides:

- GPS location/Operation maps
- Out-of-area and movement alert with location and time
- Engine, nighttime, and calendar lock

Maintenance Management

KOMTRAX monitors the health of your machines and provides critical information so that you, and your distributor, can take proactive maintenance measures and reduce downtime. KOMTRAX provides:

- Service Meter Reading (SMR)
- Cautions/Abnormality codes
- Maintenance replacement notifications

Easy and Flexible Access to Information

With KOMTRAX, information about your machines is available through a convenient, internet-based portal. KOMTRAX provides:

- A user-friendly KOMTRAX website with customized access to your machine information
- E-mail and text alerts
- Web dial-up service
- Monthly fleet summary reports

For more information, including terms and conditions of the manufacturer complimentary KOMTRAX communication service, ask your distributor, pick up a KOMTRAX brochure, or go to www.komatsuamerica.com/komtrax.

KOMTRAX®

For construction and compact equipment.

KOMTRAX Plus

For production and mining class machines.

KOMATSU PARTS & SERVICE SUPPORT



Komatsu is an industry leader in building reliable and technologically advanced machines. It is only fitting that we would provide superior Product Support. Komatsu and its distributors are focused on providing their customers unparalleled Product Support throughout the entire lifecycle of the machine. It's called Komatsu CARE.

Komatsu CARE – Complimentary Scheduled Maintenance

Komatsu remains focused on lowering the customer's ownership costs by engineering machines with increased fuel efficiency and productivity. In addition, one Komatsu CARE program aimed at further reducing your owning and operating costs is Complimentary Scheduled Maintenance. Komatsu machine owners can now rely on their Komatsu Distributor to perform the preventative maintenance on their Komatsu Tier 4 machines.

- Complimentary scheduled maintenance for the earlier of 3 years or 2,000 hours is standard on all Komatsu Tier 4 construction machines and is available at all distributors in the U.S. and Canada.
- Two complimentary Komatsu Diesel Particulate Filter exchanges within the first five years.
- Service is performed by factory certified technicians using only Komatsu Genuine parts and fluids
- Significantly lowers your cost of ownership while maintaining high equipment uptime and reliability
- Increases resale value and provides detailed maintenance records

Komatsu CARE – Extended Coverage

Komatsu equipment is built to withstand harsh operating environments, but our Extended Coverage can provide further peace of mind by protecting customers from unplanned expenses and impacts in cash flow. Purchasing Komatsu CARE's Extended Coverage locks-in the cost of covered parts and labor for the extended warranty period and helps to turn these variable expenses into a fixed cost.

- No Stop Loss or Loss Limits imposed, regardless of the coverage type or repair expense
- Any combination of months and hours out to five years and 10,000 engine hours – KOWA kits included
- Coverage premium can be rolled into the machine financing at time of sale or purchased any time before the expiration of the machine's standard warranty
- Coverage is fully transferable and honored by all Komatsu distributors throughout the U.S. and Canada

Komatsu CARE – Total CARE

Total CARE combines the benefits of the Komatsu CARE Scheduled Maintenance and Extended Coverage programs on your Tier 4 machine. This ensures the use of Komatsu genuine parts and fluids during regular maintenance intervals as well as highly skilled and efficient technicians to perform any other warranty repair work that might be necessary to keep your Komatsu equipment running like new.

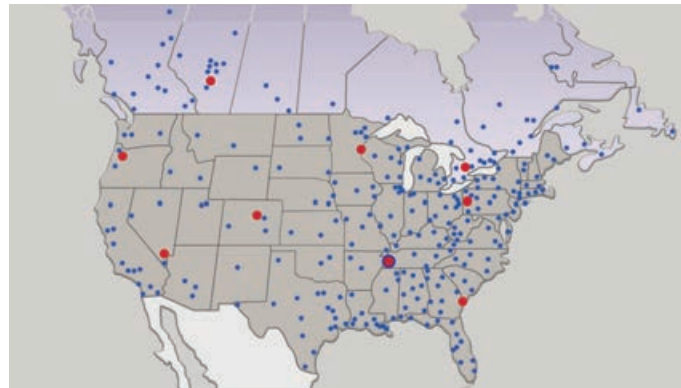

Komatsu Parts Support

Because downtime can be costly, Komatsu maintains a strategic distribution network throughout the U.S. and Canada, to ensure superior parts availability and to keep your Komatsu machine up and running.

- Komatsu America has nine Parts Distribution Centers strategically located throughout the U.S. and Canada
- Komatsu America's Parts distribution network is accessible 24/7/365 to fulfill your parts needs
- Komatsu has a distributor network of over 325 locations across the U.S. and Canada
- Online parts ordering available through Komatsu eParts, 24/7/365. (See distributor for details)
- Komatsu offers a full line of factory Remanufactured products with same-as-new warranties at a significant cost reduction:
 1. Complete Engine Assemblies
 2. Transmissions
 3. Torque Converters
 4. Hydraulic components
 5. Starters, Alternators, turbochargers and circuit boards

Komatsu Oil and Wear Analysis (KOWA)

The KOWA program uses independent laboratories across the United States to determine how your machine is performing based on a small sample of oil or other fluid. Just like a doctor will take a blood test to check on your personal health, KOWA allows you to check how your equipment is performing. Used with PM Clinic and PM Tune Up, KOWA is one of your best tools for proactively maintaining your Komatsu equipment and maximizing its availability and performance.

KOWA detects fuel dilution and coolant leaks, identifies contaminants, and measures wear-metals. Your distributor will help you interpret this information so you can identify potential problems and head them off before they lead to major repairs.

For more information of all of the manufacturer sponsored programs mentioned in this brochure, including terms and conditions of the individual programs, please speak with your distributor or go to www.komatsuamerica.com

SPECIFICATIONS

WA470-7



ENGINE

Model..... Komatsu SAA6D125E-6*
 Type Water-cooled, 4-cycle
 Aspiration..... Turbo-charged, after-cooled, cooled EGR
 Number of cylinders..... 6
 Bore 125 mm **4.9"**
 Stroke 150 mm **5.9"**
 Piston displacement..... 11.04 ltr **674 in³**
 Governor..... All-speed, electronic
 Horsepower:
 SAE J1995..... Gross 204 kW **273 HP**
 ISO 9249 / SAE J1349 Net 203 kW **272 HP**
 Rated rpm..... 2000 rpm
 Fan drive method for radiator cooling..... Hydraulic
 Fuel system..... Direct injection
 Lubrication system:
 Method..... Gear pump, force-lubrication
 Filter..... Full-flow type
 Air cleaner..... Dry type with double elements and dust evacuator, plus dust indicator

*EPA Tier 4 Interim and EU stage 3B emissions certified



TRANSMISSION

Torque converter..... 3-elements, 1-stage, 2-phase
 Transmission..... Automatic full-powershift, countershaft type

Travel speed	Forward*	Reverse*
1st	7.6 km/h 4.7 mph	7.9 km/h 4.9 mph
2nd	13.1 km/h 8.1 mph (13.2 km/h 8.2 mph)	13.5 km/h 8.4 mph (13.7 km/h 8.5 mph)
3rd	22.9 km/h 14.2 mph (23.6 km/h 14.7 mph)	23.6 km/h 14.7 mph (24.3 km/h 15.1 mph)
4th	36.2 km/h 22.5 mph (38.3 km/h 23.8 mph)	37.3 km/h 23.2 mph (39.0 km/h 24.2 mph)

*P-mode Measured with 26.5-R25 tires (): Lock-up clutch ON



AXLES AND FINAL DRIVES

Drive system Four-wheel drive
 Front Fixed, semi-floating
 Rear Center-pin support, semi-floating, 26° total oscillation
 Reduction gear Spiral bevel gear
 Differential gear Conventional type
 Final reduction gear Planetary gear, single reduction



BRAKES

Service brakes Hydraulically actuated, wet disc brakes actuate on four wheels
 Parking brake..... Wet disc brake
 Emergency brake..... Parking brake is commonly used



STEERING SYSTEM

Type Articulated type, fully-hydraulic power steering
 Steering angle..... 35° each direction (40° to max end stop)
 Minimum turning radius at the center of outside tire 6630 mm **21' 9"**



HYDRAULIC SYSTEM

Steering system:
 Hydraulic pump..... Piston type
 Capacity 195 ltr/min **51.5 U.S. gal/min** at rated rpm
 Relief valve setting 24.5 MPa 250 kgf/cm² **3,555 psi**
 Hydraulic cylinders:
 Type Double-acting, piston type
 Number of cylinders..... 2
 Bore x stroke 90 mm x 441 mm **3.5" x 17.3"**

Loader control:
 Hydraulic pump..... Piston pump
 Capacity 260 ltr/min **68.7 U.S gal/min** at rated rpm
 Relief valve setting 34.3 MPa 350 kgf/cm² **4,980 psi**
 Hydraulic cylinders:
 Type Double-acting, piston type
 Number of cylinders—bore x stroke:
 Lift cylinder..... 2- 140 mm x 764 mm **5.5" x 30.0"**
 Bucket cylinder 1- 160 mm x 575 mm **6.3" x 22.6"**
 Control valve 2-spool type
 Control positions:
 Boom Raise, hold, lower, and float
 Bucket..... Tilt-back, hold, and dump
 Hydraulic cycle time (rated load in bucket)
 Raise 6.1 s
 Dump 1.6 s
 Lower (Empty)..... 3.1 s



SERVICE REFILL CAPACITIES

Cooling system 80 ltr **21.1 U.S. gal**
 Fuel tank 380 ltr **100.4 U.S. gal**
 Engine..... 38 ltr **10.0 U.S. gal**
 Hydraulic system..... 173 ltr **45.7 U.S. gal**
 Axle front 57 ltr **15.1 U.S. gal**
 Axle rear..... 56 ltr **14.8 U.S. gal**
 Torque converter and transmission..... 65 ltr **17.2 U.S. gal**



BUCKET SELECTION GUIDE

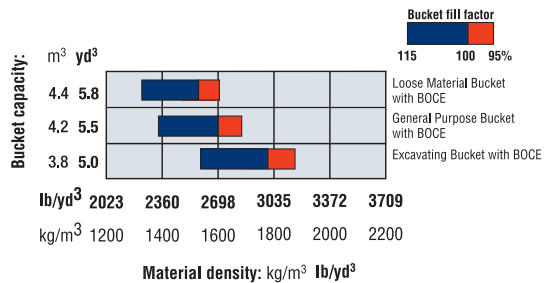



DIMENSIONS

Measured with 26.5-R25 (L3) tires, ROPS/FOPS cab

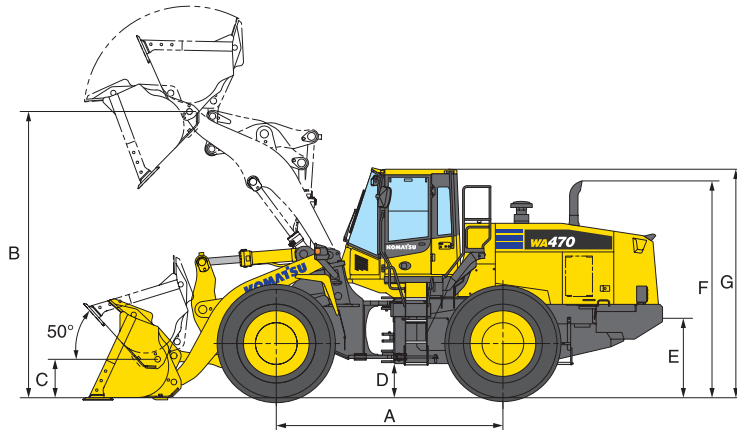

Tread	2300 mm	7'7"
Width over tires	3010 mm	9'11"
A Wheelbase	3450 mm	11'4"
B Hinge pin height, max. height	4360 mm	14'4"
C Hinge pin height, carry position	585 mm	1'11"
D Ground clearance	525 mm	1'9"
E Hitch height	1210 mm	4'0"
F Overall height, top of the stack	3300 mm	10'10"
G Overall height, ROPS cab	3500 mm	11'6"

	General Purpose Bucket	Excavating Bucket	Loose Material Bucket
	Bolt-on Cutting Edge	Bolt-on Cutting Edge	Bolt-on Cutting Edge
Bucket capacity: heaped	4.2 m ³	3.8 m ³	4.4 m ³
	5.5 yd³	5.0 yd³	5.8 yd³
struck	3.5 m ³	3.2 m ³	3.9 m ³
	4.6 yd³	4.2 yd³	5.1 yd³
Bucket width	3170 mm	3170 mm	3170 mm
	10'5"	10'5"	10'5"
Bucket weight	2020 kg	2170 kg	2210 kg
	4,453 lb	4,784 lb	4,872 lb
Dumping clearance, max. height and 45° dump angle*	3185 mm	3235 mm	3055 mm
	10'5"	10'7"	10'0"
Reach at max. height and 45° dump angle*	1235 mm	1185 mm	1365 mm
	4'1"	3'11"	4'6"
Reach at 2130 mm (7') clearance and 45° dump angle*	1935 mm	1905 mm	2010 mm
	6'4"	6'3"	6'7"
Reach with arm horizontal and bucket level*	2755 mm	2685 mm	2940 mm
	9'0"	8'10"	9'8"
Operating height (fully raised)	5960 mm	5910 mm	5960 mm
	19'7"	19'5"	19'7"
Overall length	8825 mm	8755 mm	9010 mm
	28'11"	28'9"	29'7"
Loader clearance circle (bucket at carry, outside corner of bucket)	15300 mm	15260 mm	15390 mm
	50'2"	50'1"	50'6"
Digging depth: 0°	80 mm	80 mm	80 mm
	3.2"	3.2"	3.2"
10°	315 mm	305 mm	345 mm
	1'0"	1'0"	1'2"
Static tipping load: straight	19110 kg	18970 kg	18930 kg
	42,130 lb	41,822 lb	41,733 lb
40° full turn	16470 kg	16330 kg	16300 kg
	36,310 lb	36,001 lb	35,935 lb
Breakout force	192 kN	203 kN	168 kN
	19600 kgf	20710 kgf	17140 kgf
Operating weight	23590 kg	23740 kg	23780 kg
	52,007 lb	52,338 lb	52,426 lb

* At the end of tooth or B.O.C.E.

All dimensions, weights, and performance values based on SAE J732c and J742b standards.

Static tipping load and operating weight shown include lubricant, coolant, full fuel tank, ROPS cab, and operator. Machine stability and operating weight affected by counterweight, tire size, and other attachments.

Apply the following weight changes to operating weight and static tipping load.



WEIGHT CHANGES

Tires or attachments	Operating weight		Tipping load straight		Tipping load full turn	
	kg	lb	kg	lb	kg	lb
Remove additional counterweight	-400	-882	-1300	-2866	-1100	-2425



STANDARD EQUIPMENT

- 2-spool valve for boom and bucket control
- Alternator, 50 A
- Auto shift transmission with mode select system
- Automatic hydraulic-driven fan with automatic reverse rotation
- Back-up alarm
- Batteries, 140 Ah/12V (2), 930 CCA
- Battery disconnect
- Boom Kick-out, in-cab adjustable
- Bucket Positioner, in-cab adjustable, 3 positions
- Color rear view camera and monitor
- Counterweight, standard and additional
- Electronically Controlled Suspension System (ECSS)
- Engine, Komatsu SAA6D125E-6 diesel
- Engine shut-off system, electric
- EPC fingertip controls with F-N-R switch, two levers
- Equipment Management Monitoring System (EMMS)
 - Lights (central warning, brake oil pressure, engine oil pressure, parking brake, cooling fan reverse, KDPF restriction, seat belt caution, Komtrax message)
- Gauges (Engine water temperature, ECO, Fuel level, Hydraulic oil temperature, speedometer/tachometer)
 - Front fenders
 - Fuel pre-filter with water separator
 - Horn, electric
 - Komatsu SmartLoader Logic
 - Komatsu Auto Idle Shutdown
 - KOMTRAX® Level 4
 - Lift cylinders and bucket cylinder
 - Lights
 - Back-up light, LED
 - Stop and tail light, LED
 - Turn signal lamps, 2 front and 2 rear with hazard switch
 - Working lights, halogen, 2 front cab mount
 - Working lights, halogen, 2 front fender mount
 - Working lights, halogen, 2 rear grill mount
 - Loader linkage with standard lift arm
 - Lock-up torque converter
 - Parking brake, electric
 - Radiator, wider core
 - Radiator mask, swing out
 - Rear view mirrors, outside (2) inside (2)
 - Rims for 26.5-25 tires
- ROPS/FOPS Cab Level 2
 - 2 x DC12V electrical outlets
 - Ashtray
 - Auto air conditioner
 - Cigarette lighter, 24V
 - Color LCD/TFT multi-monitor
 - Cup holder
 - Floor mat
 - Operator seat, reclining, air suspension type, heated
 - Radio, AM/FM with AUX input jack
 - Rear defroster, electric
 - Seatbelt, 2-point retractable, 76mm 3" width
 - Space for Lunch box
 - Steering wheel, tilt and telescopic
 - Sun visor, front window
 - Windshield washer and wiper, front with intermittent
 - Windshield washer and wiper, rear
- Service brakes, wet disc type
- Starting motor, 7.5 kW
- Transmission, 4 forward and 4 reverse
- Vandalism protection kit, padlocks for battery box (2)



OPTIONAL EQUIPMENT

- 3-spool valve with lever and piping
- Auxiliary steering (SAE)
- Cutting edge (bolt-on type)
- Engine pre-cleaner with extension
- High-lift boom
- Joystick/wheel steering control system
- Limited slip differential (F&R)
- Monolever loader control with transmission F-N-R switch
- Rear full fenders
- Various tire options, radial and bias
- Various bucket options

WA470-7

KOMATSU®