



REPUTATIONS
ARE BUILT ON IT

70*z7*

Tier 4 Final
Certified

168 HP 125 Kw
Engine Net Horse Power

3.7 Yd³ 2.8 M³
Bucket Capacity

32,100 Lbs 14,560 Kg
Operating Weight



70Z7

The 70Z7 US Tier 4 Final Certified, EU Stage IV emission standard loader, defines a new standard in production class wheel loaders. KCM provides a totally focused approach to supporting your business, from carefully designed programs and services, to the most technologically advanced products, KCM and the 70Z7 wheel loader are ready to tackle the most demanding applications and environments.



THE KCM DIFFERENCE

POWERFUL. EFFICIENT. INTELLIGENT. COMFORTABLE.

KCM pioneered the Z-Link design to provide unmatched utility, high breakout force and efficiency in its loaders. The Z7 generation implements brand-new patented technology, industry exclusive innovation, and input from owners, and operators all over the world. We've engineered the Z7 series from the ground up!

1 POWERFUL

Custom Operating Power Modes, made available through the KCM IntelliTech Operating System, maximize a High Engine Power Rating to provide power on demand.

2 EFFICIENT

Quick Cycle functions and Powertrain Efficiencies work together through the IntelliTech Operating System to improve operating efficiency and reduce operating costs.

3 INTELLIGENT

The KCM IntelliTech Operating System uses logic and intelligence to adjust the operating characteristics of the loader. Our intuitive system captures every aspect of working conditions and operating demands to adjust the powertrain and hydraulics for best application requirements. All of the KCM IntelliTech features are designed to maximize performance.

4 COMFORTABLE

The new Z7 operator compartment features a low-profile dash, full length glass doors, panoramic front window, standard rearview camera and well-organized storage areas-plus much more. KCM has total operator comfort in mind!

PARTNERSHIP

Through our long-term commitment to maintaining a leadership position in technology, service and support, KCM supports an extensive network of independent, local dealers focused on providing you with knowledgeable and experienced sales, service and parts personnel. All backed by dedicated KCM support teams.

Your KCM Dealer has the resources, knowledge and personnel to work with you to ensure that you receive the most benefit from your wheel loader investment.

- Carefully designed programs and services
- Extensive training at the KCM Training Center, customer and dealer locations

AT YOUR SERVICE

KCM provides a totally focused approach to supporting your business.

- Fluid sampling program
- Predictive maintenance program
- Custom warranty programs
- Custom maintenance and repair agreements
- Fully equipped, in-house rebuild center
- 24 hour parts shipments
- Genuine KCM parts



POWERFUL. EFFICIENT.

Efficiency is getting the job done with the least amount of waste. The Z7s are very efficient loaders.

The hydraulic system is designed for maximum performance and efficiency. The systems and controls allow for efficient operation. Servicing is efficient and reduces operating costs even further.

Power and productivity are what makes KCM loaders famous. The Z7 has moved to another level in this area.

Strong, responsive engines provide the power to get the job done.

Powerful hydraulics make the work easy and the productivity high.

SIMPLE EMISSIONS

The 70Z7 has one of the simplest emission systems in the industry. By eliminating the DPF, there is no need for DPF regeneration. Simple is better. Using only SCR keeps the emission system simple but effective. This is efficiency at its best.

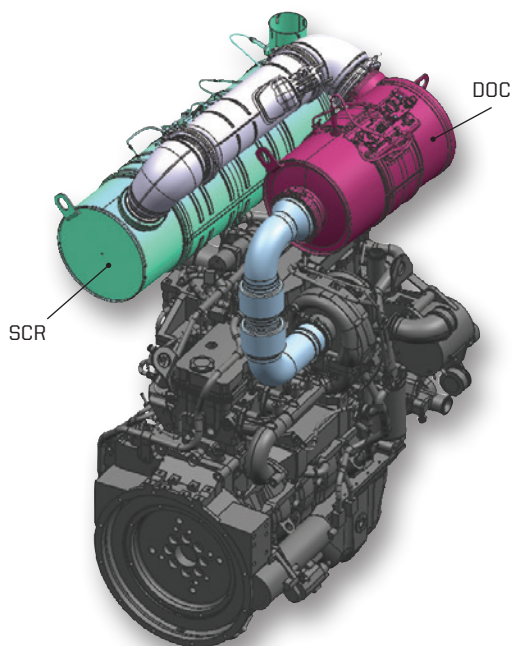

- NO DPF
 - NO DPF regeneration
 - NO DPF plugging due to high idle time
 - NO DPF plugging due to low ambient temperatures
 - NO DPF cleaning
 - Simpler engine environment
- SCR only
 - All Tier 4 Final engines require DEF to reduce NOx



FUEL EFFICIENT

The 70Z7 is among the most fuel efficient loaders in the market. Fuel efficiency means cost savings that are significant over the life of the machine. This fuel efficiency is achieved by use of the latest technologies and Cummins engines designed to run efficiently without loss of performance or reliability. The 70Z7 powertrain and hydraulic systems are designed to work together to minimize fuel usage and optimize energy efficiency. This critical balance in systems provides the best performance at the lowest cost.

- Piston pumps are load sensing so they provide efficient use of hydraulic power and response with the lowest horsepower demand.
- Controlled acceleration allows the 70Z7 to achieve excellent acceleration without unnecessary fuel consumption. This is achieved through sophisticated logic in the controller that allows for precise fuel delivery to match acceleration objectives.
- Transmission shift points are flexible to match working conditions to allow for the proper speed/rimpull balance to meet the job conditions.
- Fuel efficient Cummins Engines are designed to minimize fuel consumption.



RELIABLE CUMMINS POWER

The Cummins diesel engine in the 70Z7 offers power and efficiency. Cummins is one of the largest diesel engine manufacturers in the world and has provided outstanding products for the wheel loader market for over 50 years.

- Proven performance and efficiency
- Reliable, long life engine
- Extensive support network throughout North America provides outstanding service



INTELLIGENT.

Intelligence in a wheel loader refers to the programming and processes implemented to adapt to the working conditions, improving efficiency and productivity.

The KCM IntelliTech system is a family of features that optimize the performance of the loader in any working environment and application.

INTELLITECH SYSTEMS THAT ADAPT

The advanced technology used in the 70Z7 provides systems that can adjust to working conditions to provide optimum productivity. These systems take operating information and modify powertrain and hydraulic systems to operate efficiently and effectively.

Operators can control some systems to suit their requirements while other systems adjust automatically to the conditions that the machine is experiencing.



- IntelliDig balances the rimpull force with the breakout force to provide optimum digging performance automatically
- Variable, reversible fan is aerodynamically designed for efficient airflow, with variable speed to reduce energy loss when high fan speed is not required, and is automatically reversible to keep the cores cleaner in dusty conditions for better efficiency



EFFICIENT OPERATION

Efficiency is critical to increasing production and profitability. To gain optimum efficiency KCM has developed systems that optimize efficiency using demanding design standards as well as state-of-the-art technology.

- Power modes for high power demands or high fuel efficiency
- High efficiency bucket design loads faster, retains more material, increases productivity

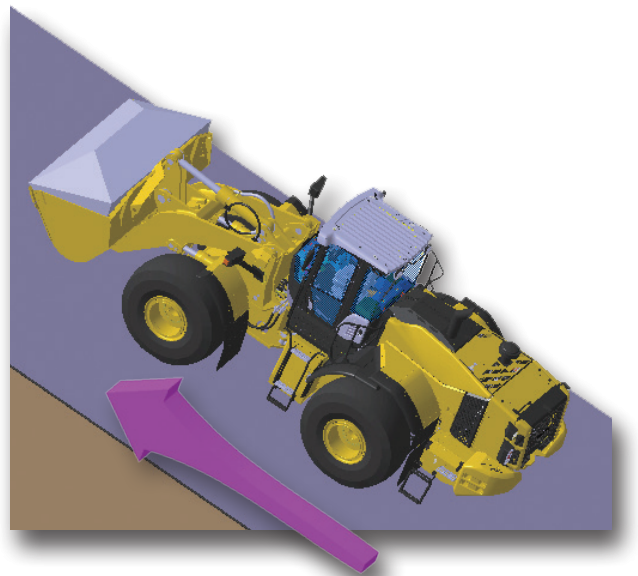

OPEN CENTER LOAD-SENSING HYDRAULICS

The Z7 generation wheel loaders use open center load-sensing hydraulics, well proven in hydraulic excavators. Open center load-sensing hydraulics are more responsive than commonly found closed center hydraulics, and are more reliable. Sensors feeding the Intellitech system provide immediate feedback which operators rely on for efficiency and safety.

- Responsive – operator senses load resistance
- Industry exclusive
- Reliable



COMFORTABLE.

A comfortable operator is a productive operator. In the Z7s the operator comfort is outstanding. Quiet, convenient, clean and designed for optimum operator comfort, safety, and productivity. Offering improved controllability, the Z7s offer a full color LCD multi-function instrument panel providing clear, concise information derived from the KCM IntelliTech System, including machine operation and settings.

COMFORT ➤ PRODUCTIVITY

Productivity is one of the most critical factors in wheel loaders. The 70Z7 productivity is due in large part to the outstanding comfort offered to the operator in this roomy ROPs cab.

- Hydraulic controls are fingertip, pilot assisted levers. Either single or dual lever controls are available to fit the operator preference.
- Sound levels are low to reduce operator fatigue and allow the operator to monitor external noises for increased comfort and safety.
- The air suspension seat provides outstanding comfort and adjustability which keeps the operator comfortable over the entire work shift.
- The steering wheel has a tilting/telescoping steering column that adjusts to fit operator preference.



CONVENIENCE ➤ EFFICIENCY

Convenience is a necessity if the operator is going to be efficient. This means ergonomic design in controls, displays, and access/egress. The 70Z7 cab has several convenience features that make this machine an operator's choice.

- Ample storage on large shelves
- A** ■ A thermal box that keeps food cool in the summer and warm in the winter
- B** ■ Dual dome lights
- C** ■ Dual cup holders allow for a variety of cup or thermos sizes
 - Auxiliary electrical outlets for 12V or 24V provide power for radios, chargers or other accessories
 - Common key for the cab door and ignition
- D** ■ Ladders, inclined for easy access and egress
- E** ■ AM/FM/AUX radio

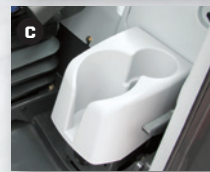
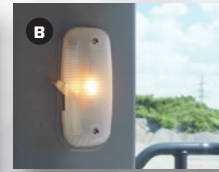



VISIBILITY ➤ **SAFETY**

One of the most important safety features of the 7027 is the outstanding visibility in all directions. As safety becomes more critical to all operations, having the great visibility of the 7027 is a major operator asset. Not only does it improve safety, but when the operator feels safe, he is more productive and efficient.

- Large tinted windshield with wiper/washer offer a panoramic view to the working area
- Rear camera monitors provide rear visibility to avoid obstructions or unsafe conditions
- Pillar-less rear window provides clear view to the back and sides of the machine for faster maneuvering
- External and Internal rearview mirrors give the operator a good view while traveling in reverse to speed cycle



SERVICE SIMPLIFIED.

Routine maintenance and servicing is efficient from start to finish. From the Global e-Service Telematics system monitoring your maintenance needs, to the easy access, ground level site gauges and fittings, the Z7 loaders are designed to simplify your maintenance management.

EASY ACCESS

Serviceability and safety are engineered into every Z7 wheel loader. Maintenance programs, functions are all designed to reduce your maintenance time and expense. Our high standard for safety ensures operator confidence enabling maximum performance.

- Ladders, inclined
- Wide-access engine compartment
- Battery disconnect
- Easy access battery box
- Grouped lube points
- Ground-level fluid check points
- Ground-level fueling
- Fuse-relay panel in cab
- Autolube, optional



EXTENDED SERVICE

Extended hydraulic and engine oil intervals

KCM Super EX46 is a specially formulated hydraulic fluid with no zinc additive. Zinc causes a sludge buildup in oil that shortens the effective life of the oil. By using KCM Super EX46 HN Hydraulic Fluid the sludge buildup is reduced which allows for extended life, which lowers operating costs.

Using CJ4 engine oil, which is a low ash oil, allows the change intervals to be extended. By doubling the oil change interval from 250 hours to 500 hours, the time and cost of engine oil changes are cut in half.

Extended lube intervals from patented HN bushings

The patented HN™ bushings are impregnated with high viscosity oil to provide added lubrication. This allows the lubrication interval to be extended on bucket linkage pins. The lubricant is replenished every time the pin is greased.





TELEMATICS

Global e-Service is the proprietary telematics system for KCM loaders. This system monitors all machine systems and collects operating data and alerts, which it transmits to equipment managers, dealers and factory support staff at KCM. This system allows for more efficient management of fleets, control of maintenance schedules and notification of alerts that can reduce downtime and operating costs.

- Location
- Hours
- Idle time
- Fuel consumption
- Alerts

SPECIFICATIONS

MODEL NAME: 70Z7, EPA TIER 4 FINAL/ EU STAGE IV CERTIFIED

ENGINE	
Net Power (SAE J1349) ISO 9249	168 HP/2,200 RPM (125 kW/2,200 RPM)
Make/Model	Cummins QSB6.7 diesel engine
Type	4-cycle, water-cooled, direct injection with turbocharger and air cooled intercooler
Fuel type	#2 Diesel (Requires ultra-low sulfur fuel.)
Fuel injection pump	Electronically controlled, common rail type
Governor	All speed electrical type
Cooling module type	Hydraulic-driven, suction-type fan, pressurized radiator
Number of cylinders	6
Bore and stroke	4.213" x 4.882" (107mm x 124mm)
Total displacement	408.2 in ³ (6.69 liters)
Alternator	AC 24V-1.56 kW (65A)
Air cleaner	Dry type (double element)
Starter motor	DC 24V-7.8 kW (10.5 HP)
Battery	12V-108AH (850 CCA), 2 units

TORQUE CONVERTER AND TRANSMISSION		
Torque converter	3-element, single-stage, 1-phase	
Transmission	Countershaft type, Full power shift	
	Normal Mode	Power Mode
Speeds: Forward	1st: 3.7 MPH (5.9 km/hr)	1st: 3.9 MPH (6.3 km/hr)
	2nd: 7.1 MPH (11.5 km/hr)	2nd: 7.6 MPH (12.2 km/hr)
	3rd: 10.8 MPH (17.4 km/hr)	3rd: 11.5 MPH (18.5 km/hr)
	4th: 15.7 MPH (25.3 km/hr)	4th: 16.8 MPH (27.0 km/hr)
	5th: 23.9 MPH (38.5 km/hr)	5th: 23.9 MPH (38.5 km/hr)
Speeds: Reverse	1st: 3.9 MPH (6.2 km/hr)	1st: 4.1 MPH (6.6 km/hr)
	2nd: 7.5 MPH (12.1 km/hr)	2nd: 8.0 MPH (12.9 km/hr)
	3rd: 16.5 MPH (26.5 km/hr)	3rd: 17.6 MPH (28.3 km/hr)

SYSTEMS REFILL CAPACITY		
LOCATION	GALLONS	LITERS
Fuel tank (diesel fuel)	62.1	235
Engine lubricant (including oil pan)	6.6	25
Engine coolant	7.9	30
T/M & T/C	5.5	21
Axle (front/rear)	8.2/9.0	31/34
Hydraulic oil tank	26.4	100
Hydraulic system (including hydraulic tank)	39.6	150
DEF/AdBlue® tank	6.6	25

HYDRAULIC AND STEERING SYSTEM		
Steering type	Articulated frame steering	
Steering mechanism	Hydraulic power steering unit, direct operated type	
Lift (boom) cylinder	Two (2) double-acting piston type: 4.921" x 30.118" (125mm x 765mm)	
Tilt (bucket) cylinder	One (1) double-acting piston type: 5.910" x 19.490" (150mm x 495mm)	
Steering cylinder	Two (2) double-acting piston type: 2.756" x 17.401" (70mm x 442mm)	
Main oil pump	Variable Piston type: 55.5 GPM/710 psi @ 2200 RPM (210 LPM/4.9 MPa @ 2200 RPM)	
Pilot oil pump	Gear type: 9.3 GPM/566 psi @ 2200 RPM (35.1 LPM/3.9 MPa @ 2200 RPM)	
Relief valve set pressure	Loading	3,974 psi, 27.4 MPa (280 kgf/cm ²)
	Steering	3,684 psi, 25.4 MPa (260 kgf/cm ²)
HYDRAULIC CYCLE TIME* front end loading, Z bar linkage system		
	Normal Mode	Power Mode
Lifting time (at full load)	5.9 sec.	5.7 sec.
Lowering time (empty)	3.6 sec.	3.6 sec.
Bucket dumping time	1.3 sec.	1.3 sec.
TOTAL	10.8 sec.	10.6 sec.

* Measured in accordance with SAE J732C

AXLE SYSTEM	
Drive system	4-wheel drive
Front and rear axle	Semi-floating type
Tires	20.5-25-12PR (L-2) (L-3) Tubeless
	23.5-25-12PR (L-2) (L-3)
Reduction and differential gear	Spiral bevel gear, limited slip, single stage reduction
Final reduction gear	Inboard mounted, internal planetary gear
Oscillation angle	±12°





BRAKE SYSTEM	
Service brakes	4-wheel, wet multiple disc brake. Controlled by fully hydraulic system. Dual circuit.
Parking/Emergency brake	Spring-applied, oil pressure-released. Located on driveline.

REMARKS

- Materials and specifications are subject to change without notice and without any obligation on the part of the manufacturer.
- This information, while believed to be completely reliable, is not to be taken as warranty for which we assume legal responsibility.
- Dumping clearance and reach are measured from bucket edge in accordance with SAE J732C.
- Color for model shown in this brochure is a standard KCM yellow.
- This specification sheet may contain attachments and optional equipment not available in your area.

Please contact your local KCM dealer for additional information.

BUCKET DATA

			Standard Boom				High Lift Boom
			General Purpose		Material Handling	Quick Coupler	Material Handling
			Straight Edge With Bolt-on Cutting Edge	Straight Edge With Teeth and Segments	Straight Edge With Bolt-on Cutting Edge	Straight Edge With Bolt-on Cutting Edge	Straight Edge With Bolt-on Cutting Edge
							
Capacity	Heaped	yd ³ (m ³)	3.7 (2.8)	3.7 (2.8)	4.2 (3.2)	3.4 (2.6)	3.7 (2.8)
	Struck	yd ³ (m ³)	3.3 (2.5)	3.3 (2.5)	3.5 (2.7)	3 (2.3)	3.3 (2.5)
A	Maximum dumping clearance	ft-in (mm)	9'1/2" (2,760)	8'9 1/2" (2,680)	8'11 1/2" (2,730)	8'9 1/2" (2,680)	10'4 3/4" (3,170)
B	Dumping reach (to front of bucket edge or tooth)	ft-in (mm)	3'7 3/4" (1,110)	3'10 3/4" (1,190)	3'9" (1,140)	3'10 1/2" (1,180)	4'2 3/4" (1,260)
C	Max. hinge pin height	ft-in (mm)	12'10 1/4" (3,920)	12'10 1/4" (3,920)	12'10 1/4" (3,920)	12'10 1/4" (3,920)	14'2" (4,320)
D	Digging depth (with bucket level)	ft-in (mm)	3 1/2" (90)	3 1/2" (90)	3 1/2" (90)	3 1/2" (90)	6 3/4" (170)
Breakout force		lb (kN)	26,530 (118)	26,530 (118)	25,630 (114)	24,280 (108)	24,500 (109)
Bucket tilt-back angle	at ground level	degree	44°	44°	44°	44°	45°
	E at carry position	degree	50°	50°	50°	50°	50°
F	Length	ft-in (mm)	26'3" (8,000)	26'7 3/4" (8,120)	26'5" (8,050)	26'7 1/4" (8,110)	27'10 1/2" (8,500)
G	Height (up to cab top)	ft-in (mm)	10'9 1/4" (3,280)	10'9 1/4" (3,280)	10'9 1/4" (3,280)	10'9 1/4" (3,280)	10'9 1/4" (3,280)
Overall	H Height (bucket fully raised)	ft-in (mm)	17'3 1/2" (5,270)	17'3 1/2" (5,270)	17'5 1/2" (5,320)	17'5 1/2" (5,320)	18'7 1/2" (5,680)
	I Width (outside tire)	ft-in (mm)	8'6 3/4" (2,610)	8'6 3/4" (2,610)	8'6 3/4" (2,610)	8'6 3/4" (2,610)	8'6 3/4" (2,610)
J	Width (outside bucket)	ft-in (mm)	8'11 1/2" (2,730)	9'1/2" (2,760)	8'11 1/2" (2,730)	8'11 1/2" (2,730)	8'11 1/2" (2,730)
K	Tread	ft-in (mm)	6'8 3/4" (2,050)	6'8 3/4" (2,050)	6'8 3/4" (2,050)	6'8 3/4" (2,050)	6'8 3/4" (2,050)
L	Wheel base	ft-in (mm)	10'2" (3,100)	10'2" (3,100)	10'2" (3,100)	10'2" (3,100)	10'2" (3,100)
Clearance Circle (bucket carry position)	M at outside of bucket	ft-in (mm)	40'10 1/2" (12,460)	41'2 1/2" (12,560)	40'11 3/4" (12,480)	41'1" (12,520)	42'3" (12,880)
	at outside of tire	ft-in (mm)	36'3 1/4" (11,160)	36'3 1/4" (11,160)	36'3 1/4" (11,160)	36'3 1/4" (11,160)	36'3 1/4" (11,160)
N	Minimum ground clearance	ft-in (mm)	1'3 1/2" (395)	1'3 1/2" (395)	1'3 1/2" (395)	1'3 1/2" (395)	1'3 1/2" (395)
O	Full articulation angle	degree	40°	40°	40°	40°	40°
Operating weight (with ROPS cab)		lb (kg)	32,100 (14,560)	32,170 (14,590)	32,280 (14,640)	32,650 (14,810)	32,540 (14,760)
Static tipping load (with ROPS cab)	Straight	lb (kg)	26,680 (12,100)	26,590 (12,060)	26,540 (12,040)	24,600 (11,160)	21,050 (9,550)
	Full turn	lb (kg)	23,020 (10,440)	22,950 (10,410)	22,880 (10,380)	21,160 (9,600)	18,060 (8,190)

DIMENSIONS

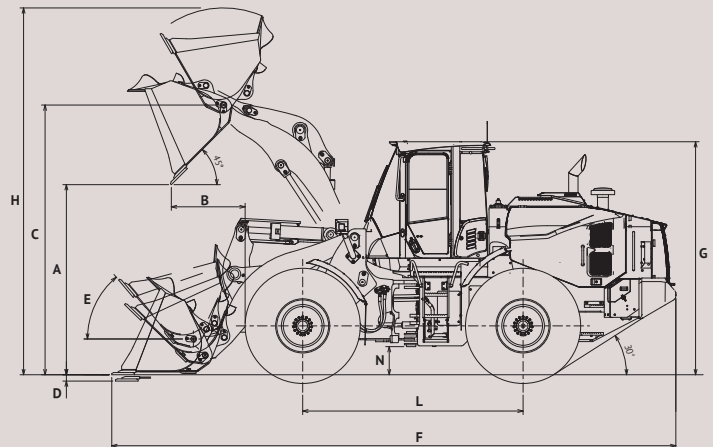
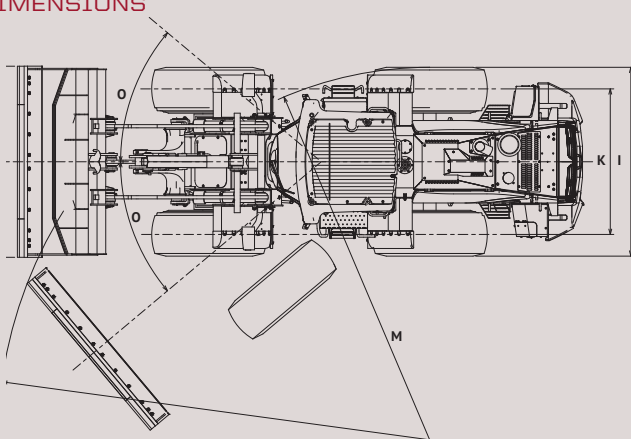

Equipped with 20.5-25-12PR (L-2) tubeless tire and ROPS cab.

SPECIFICATIONS

WEIGHTS AND DIMENSIONS

		Operating Weight	Tipping Load		Overall Width (Outside Tire)	Overall Height	Overall Length
			Straight	Full Turn			
Remove ROPS cab (for transport only)	lb (kg)	-1,140 (-540)	-1,102 (-500)	-992 (-450)	in (mm)	-5 ¹ / ₂ (-140)	
Tires: 20.5-25-12PR (L-3)	lb (kg)	+265 (+120)	+198 (+90)	+176 (+80)	in (mm)	±0 (±0)	±0 (±0)
23.5-25-16PR (L-2)	lb (kg)	+1,400 (+640)	+1,040 (+470)	+930 (+420)	in (mm)	+3 ¹ / ₂ (+90)	+2 ¹ / ₄ (+60)
23.5-25-16PR (L-3)	lb (kg)	+1,830 (+830)	+1,340 (+610)	+1,190 (+540)	in (mm)	+3 ¹ / ₂ (+90)	+2 ¹ / ₄ (+60)

BUCKET SELECTION CHART

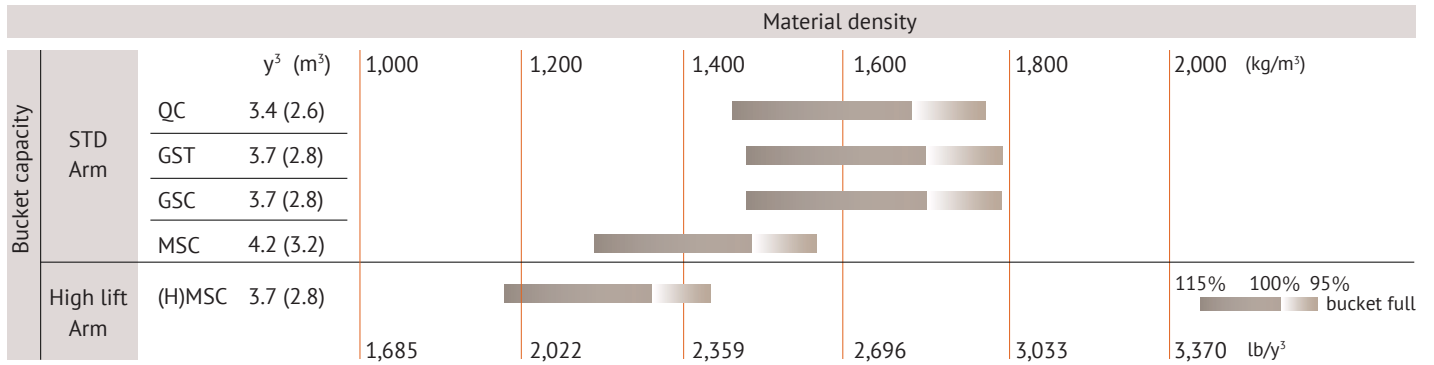

SPECIAL APPLICATIONS

WASTE HANDLING/REFUSE/RECYCLING



- Front Windshield Guard
- Belly Guard
- Wide Fin radiator
- Engine Precleaner (Turbine type)

LOGGING/WOODCHIP



- Autolube system
- Log clamp
- 3rd spool valve
- Additional counterweight

EQUIPMENT DATA

STANDARD EQUIPMENT

ENGINE

Air cleaner, double element	Fuel filter (Main)
Auto idle shut down	Fuel pre-filter, w/water separator
Cold start (intake air heater)	Rain cap
Cooling fan, automatic reversible, swing-out type	SCR catalyst and DOC
Cummins QSB6.7 diesel engine	VGT (variable geometry turbocharger)
EGR System	Work mode selector

POWERTRAIN

Brakes, service	F-R direction selector (2-column mounted/hydraulic control lever mounted)
Enclosed wet disc	
Dual system	
Inboard mounted	1st speed hold switch on side console
Brake, parking	Quick Power switch
Spring applied	
Oil pressure released	Transmission, automatic w/load sensing system.
Dry disc type	
Differential, limited slip (F/R)	Transmission declutch (3-position L/H/Off)
Down-shift switch	Transmission mode selection (3-position AUTO1/MAN/AUTO2)
Drive shafts, low maintenance	Universal joints, sealed

HYDRAULIC SYSTEM

Boom kick-out, dual (operator adjustable in cab)	Control valve, 2-spool, parallel and tandem control
Bucket positioner (horizontal)	Pump, variable displacement, load-sensing
Control lever, single, pilot-assisted	Steering, direct
Control lever lock (electric)	System; open-center, high-pressure, load-sensing

ELECTRICAL

24-volt electrical system	Lights:
Back-up alarm	2 Headlights (halogen)
Batteries (2), 12V, 1,000 CCA	2 Forward working lights (halogen)
Battery disconnect switch	4 Rear working lights (halogen)
Camera, rear-view	2 Stop/tail/backup (LED)
Converter, 12V/15 Amp	Turn signal w/4-way flashers/marker
Horn, dual electric	
Instrument panel, LCD, color	

CAB

ROPS cab: enclosed cab with sound suppression, front & rear wipers and washers, two rear view and side mirrors, tinted glass, full view latch-back doors, sliding side windows.	Coat hook
Accessory outlet, 12v	Cup holder (2)
Adjustable armrest/console, (fore/aft sliding)	Floormat, sweep-out
Air conditioner/heater/pressurizer	Retractable seat belt (3-inch)
AM/FM/WB radio with AUX input	ROPS/FOPS certified
Ashtray	Seat, air suspension, fabric
Cab dome lamps (2)	Steering column, telescoping and tilting w/quick-release pedal
Cigarette lighter, 24V	Steering wheel
	Storage box (heated/cooled)
	Storage tray
	Sun visor

ALARMS, GAUGES AND INDICATORS

Alarms (visual & audible)	Speedometer
Aftertreatment device	Tachometer
Aftertreatment device regeneration system	Transmission oil temperature
Air cleaner element	Indicators
Axle oil temperature	Aftertreatment device regeneration
Battery discharge warning	Air conditioner display
Brake oil low pressure	Boom kick-out, dual
CAN network system	Cold start
DEF/AdBlue tank level/quality/system	Control lever lock
Engine oil low pressure	Declutch
Engine trouble	ECO-Operating Status
Engine warning	Fan reverse rotation
Fuel filter (water in fuel)	F-N-R Selection
Hydraulic oil level	F-N-R Switch enable
Hydraulic oil temperature	High beam
Main pump oil pressure	Parking brake
Overheat (engine coolant)	Shift hold
Transmission oil temp	Time/Operating hour/ODO
Transmission warning	Transmission mode and status
Gauges	Turn signal w/4-way flashers/Marker
DEF/AdBlue tank level	Work light
Engine coolant temperature	Work mode (Normal, Power)
Fuel gauge	

OTHERS

Articulation locking bar	Ladders, inclined
Counterweight	Lifting eyes
Drawbar	Linkage pins, HN bushing
Fenders, front, w/mudflap	Neutral safety start
Fenders, rear, deck-type, w/mudflap	Rear grill, hinged
KCM Global e-service, telematic monitoring system (GSM-version w/4 yrs. service)	Steps, rear
	Vandalism protection
	Z-bar loader linkage

OPTIONAL EQUIPMENT

Autolube	Dual lever hydraulic control	Hydraulic system, 3 spool valve	Ride control, automatic
Belly guard, transmission	Fenders, rear, full w/mudflaps	LED work lights	Seat, heated
Bolt-on cutting edge & segments	HID work lights	Quick coupler and attachments	Secondary steering
Bucket teeth	High lift boom arm		



KCM LEGACY

▶ **KCM** REPUTATIONS ARE BUILT ON IT

KCM loaders have a rich heritage of quality, technology and outstanding support. The origins of KCM loaders can be traced to 1962 when Kawasaki Heavy Industries built their first articulated wheel loader in Japan. As one of the largest heavy industries in Japan, Kawasaki provided a depth of engineering expertise that eventually made their wheel loader a major global player. As they introduced the wheel loader into the North American market in 1978, they found a positive reception for a productive, high quality loader. They established a solid support system built around an extensive, independent network of dealers that were committed to provide quality support along with quality equipment. This strong dealer network has helped to propel the KCM loader to a prominent market position in North America.

A joint venture with Hitachi Construction Machinery Group was entered into in 2010 to further develop the global scope of the wheel loader product. This relationship combined the huge technological and manufacturing resources of Kawasaki Heavy Industries and Hitachi Construction Machinery Group together to develop the Z7 series of wheel loaders. This effort has resulted in a very productive, reliable, and cost effective product. As a subsidiary of Hitachi Construction Machinery Group, KCM Corporation is a global leader in the wheel loader market today.

The commitment of KCM Corporation to the North American market is significant. Outstanding parts availability, an unmatched factory component exchange program, customer and dealer training programs, and a wide range of services and programs, provide outstanding support for the KCM wheel loader. With manufacturing facilities in Banshu, Japan; Ryugasaki, Japan, and Newnan, Georgia KCM has the experience and technology to design, engineer, manufacture, and service your next wheel loader. The KCM team is focused on wheel loaders. Flexibility, responsiveness and ease of doing business are foundations of that commitment.

KCM Corporation

Hitachi Construction Machinery Group

KCMA Corporation | 770.499.7000 | kmccorp.com

Part #70Z7 T4F BROCH (02/2017)