

## STANDARD EQUIPMENT

### ENGINE

- Engine, ISUZU AR-4JJ1XASK-02, Diesel engine with turbocharger and intercooler, Tier 4 certified
- Automatic engine deceleration
- Batteries (2 x12V - 80 Ah)
- Starting motor (24 V - 5kW), 50 amp alternator
- Engine oil pan drain cock
- Double element air cleaner

### CONTROL

- Working mode selector (H-mode, S-mode and ECO-mode)

### SWING SYSTEM & TRAVEL SYSTEM

- Swing rebound prevention system
- Straight propel system
- Two-speed travel with automatic shift down
- Sealed & lubricated track links
- 23.6" (600mm) track shoes
- Grease-type track adjusters
- Automatic swing brake

### MIRRORS & LIGHTS

- Three rear view mirrors and rearview camera
- Two front working lights
- Swing flashers

### CAB & CONTROL

- Two control levers, pilot-operated
- Horn, electric
- Integrated left-right slide-type control box
- Cab light (interior)
- Coat hook
- Large cup holder
- Detachable two-piece floor mat
- 7-way adjustable suspension seat
- Retractable seatbelt
- Headrest
- Handrails
- Heater and defroster
- Intermittent windshield wiper with double-spray washer
- Sky light
- Top guard (ISO 10262 : 1998)
- Tinted safety glass
- Pull-type front window and removable lower front window
- Easy-to-read multi-display monitor
- Automatic air conditioner
- Emergency escape hammer
- Radio, AM/FM Stereo with speakers
- Travel alarm
- 12V converter
- Control pattern changer (2-way)

## OPTIONAL EQUIPMENT

- Front-guard protective structures (May interfere with bucket rotation)
- N&B hydraulic circuit
- Rotate hydraulic circuit
- Cab additional light
- Rain visor (may interfere with bucket action)
- Add-on type counterweight (+580kg)
- Right view camera
- Dozer Blade
- Offset boom specification

Note: Standard and optional equipment may vary. Consult your KOBELCO dealer for specifics.

Note: This document may contain attachments and optional equipment that are not available in your area. It may also contain photographs of machines with specifications that differ from those sold in your area. Please contact your nearest KOBELCO dealer for items you require. Due to our policy of continuous product improvement, all designs and specifications are subject to change without advance notice. Copyright © KOBELCO CONSTRUCTION MACHINERY CO., LTD. No part of this document may be reproduced in any manner without prior written permission from KOBELCO.

## KOBELCO CONSTRUCTION MACHINERY U.S.A. INC.

22350 Merchants Way, Katy, Texas 77449  
<http://www.kobelco-usa.com/>

Inquiries To:

Bulletin No. SK140SRLC-NA-101-160500N

# KOBELCO

Hydraulic Excavator

# SK140SRLC

SK140SRLC-5

## DRIVEN BY PASSION

■ Bucket Capacity :

0.30 - 0.88 cu. yd. SAE

■ Engine Power :

95.6 hp {71.3 kW} @ 2,000 rpm  
(SAE NET)

■ Operating Weight :

31,500 lbs {14,300 kg}



Complies with the latest exhaust emission regulations



US EPA  
Tier IV Final



EU (NRMM)  
Stage IV



Japanese  
Regulations

# Power Meets Efficiency

With iDNr for even quieter operation.

## SK140SR<sub>LC</sub>

"KOBELCO has made the short rear swing excavator the standard for mid-sized machines. And with ongoing development in innovations such as the iDNr noise reduction system that both shuts out iDNr filters dust and cuts noise, KOBELCO is boosting value and leading the industry with construction machinery ideally suited to the urban environment. The new SK140SR<sub>LC</sub> retains the compact shape and iDNr system advantages that KOBELCO has pioneered, but it has been fitted with a new engine assembly for improved environmental protection. Low fuel consumption is balanced against increased work performance, and machine durability has been advanced. The new worldwide-model SK140SR<sub>LC</sub>. Working for the planet."



# Low noise and easy maintenance mean greater value than ever A new design approach leads to a revolutionary double offset duct structure

By reviewing the iNDR configuration, Kobelco achieved both great visibility and a compelling design even though the engine compartment has been enlarged to meet TIER IV Final standards, maintaining the value of iNDR.

iNDR absorbs sound energy to minimize noise by making a path of air, which cools down engine, as one engine cooling ducts. The new model is equipped with a selective catalytic reduction (SCR) unit, which required a new design with two offset ducts on top. This allows ample space to absorb engine noise, making these new excavators as quiet as conventional models.

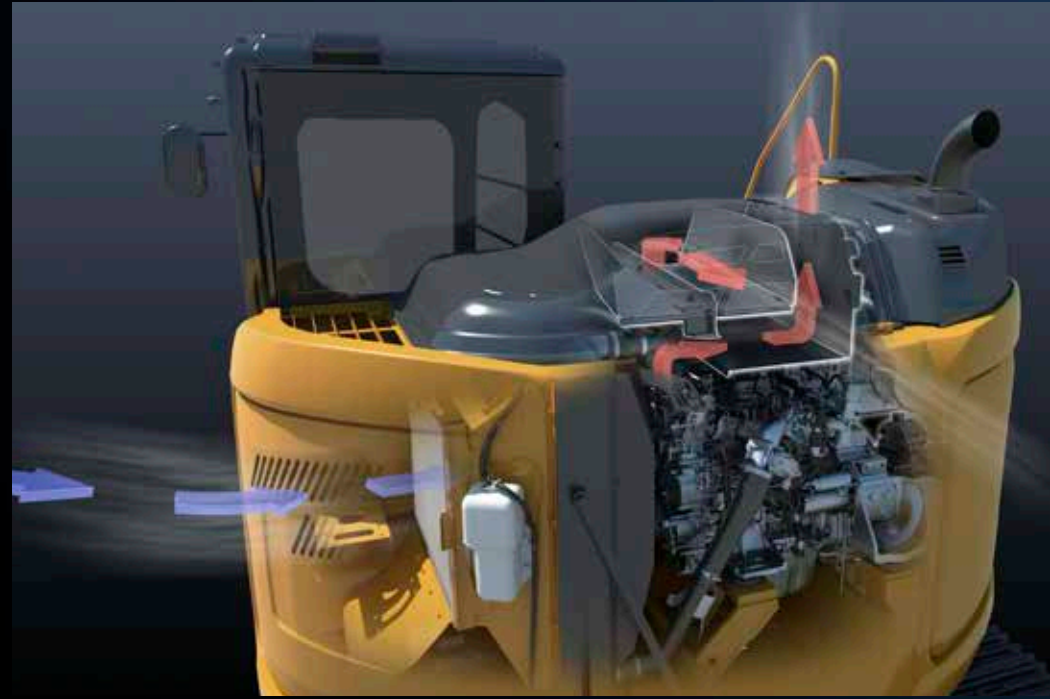

## Wide, clear view to the rear

Even with the larger engine compartment, the design minimizes hood height, ensuring an excellent direct view to the rear. In addition, the operator can monitor conditions behind the machine with clear, wide-angle images from the rear-view camera, which comes as standard equipment.



## The Results Are Exceptional. The Big Merits:

### "Ultimate Low Noise" is achieved by minimizing sound leakage during operation

Noise from the engine and cooling fan is absorbed by the duct, so the machine far surpasses legal requirements. Kobelco calls this system, which exceeds all noise standards, "Ultimate Low Noise," and it reduces noise to about 70dB(A) at 10m from center of the machine.



### Eliminating dust maintains cooling system performance

The high-density 60-mesh\* filters dust in the intake air. This prevents clogging of the cooling system and the air cleaner, which maintains peak performance. The waveform filter allows air through the tops of the waves while collecting dust at the bottom, ensuring a smooth airflow.

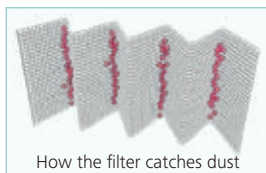

\* "60-mesh" means that there are 60 holes formed by horizontal and vertical wires in every square inch of filter.

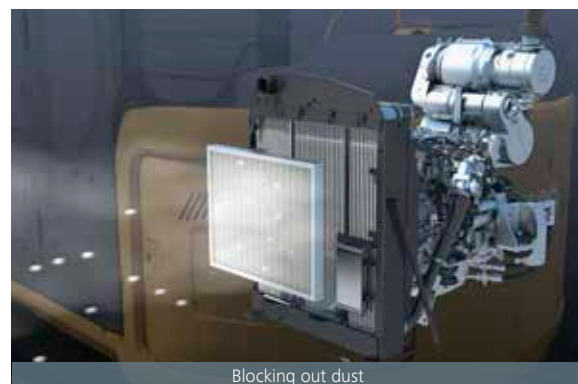

### Easy filter maintenance system simplifies cleaning

Daily inspection consists of a visual check of the iNDR filter only. If it looks dirty, it can be removed and washed without special tools.



## NOx emissions cut:

## New, Environmentally Friendly Engine

### New TIER IV Final compliance engine **NEW**

The new type of TIER IV Final compliant engine is fitted with a diesel oxidation catalyst (DOC) and an SCR device to control emissions without using a diesel particulate filter (DPF). It has a large-capacity DEF/AdBlue tank, extending intervals between fill-ups.

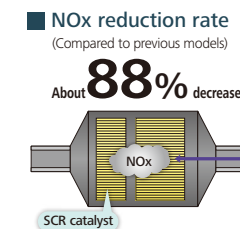

At high temperatures, nitrogen and oxygen combine to produce nitrous oxides (NOx). Reducing the amount of oxygen and lowering the combustion temperature results in much less NOx.

### EGR cooler

While ensuring sufficient oxygen for combustion, cooled emission gases are mixed with the intake air and recirculated into the engine. This reduces oxygen content and lowers combustion temperature.

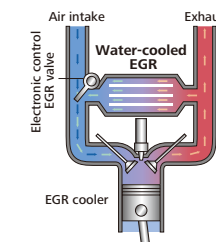

### A newly developed engine raises the bar for construction machinery

The latest Kobelco construction machinery uses an ISUZU engine that is renowned for environmental performance, and has been tuned specifically for use in Kobelco machines. This new, environmentally friendly engine changes conventional wisdom on balancing powerful performance with eco-friendliness.

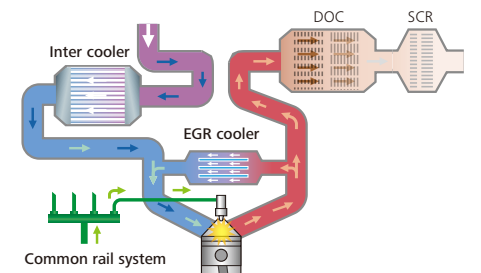

## PM emissions cut:

Particulate matter (PM) is mostly soot resulting from incomplete combustion; Improved combustion efficiency reduces PM emissions.

### Common rail system

High-pressure injection atomizes the fuel, and more precise injection improves combustion efficiency. This also contributes to better fuel economy.

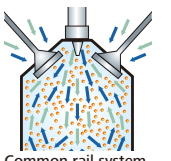

# Unbeatable Performance

Greater Work Capacity:  
Exceeding Expectations in Productivity

## Improved Fuel Efficiency Contributes to High Performance

### Superior Digging Volume

This excavator offers dynamic digging force even as it minimizes fuel consumption rates, achieving class-leading work volume. H-mode with an increased torque setting delivers about 5.2% greater digging volume.

■ Digging volume/hour  
(Compared to H-mode on previous models)



■ Max. bucket digging force

**21,357 lbf {95.0kN} (ISO 6015)**  
**20,500 lbf {91.2kN} (SAE J1179)**

■ Max. arm crowding force

**13,100 lbf {58.1kN} (ISO 6015)**  
**12,700 lbf {56.7kN} (SAE J1179)**

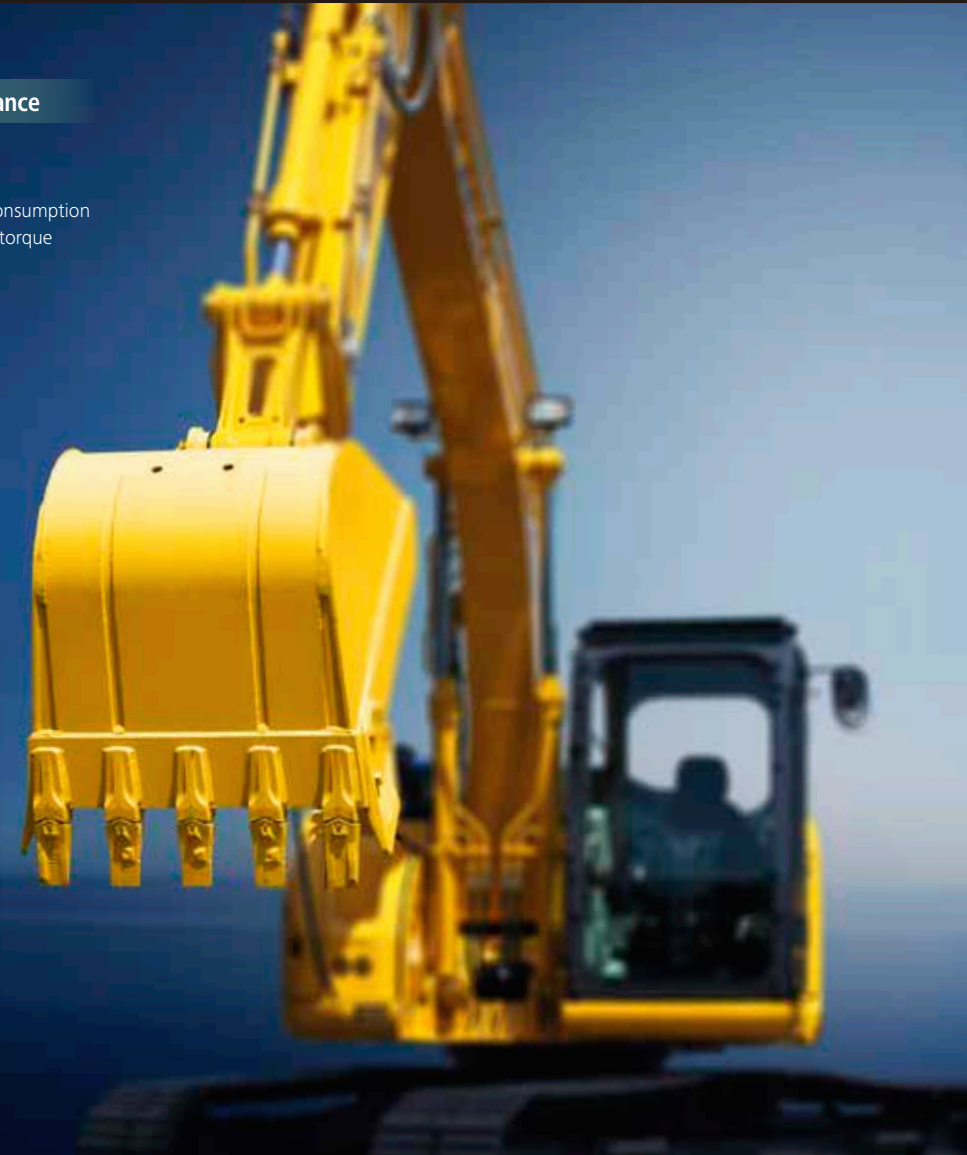

## Energy-efficient System

### ECO-mode: engineered for economy

Kobelco's ECO-mode maximizes the operating efficiency of the engine and other components to achieve much greater fuel efficiency. Just press a button to choose the operation mode best suited to the task at hand and the working conditions.

■ Optimal operation with three modes

- H** H-mode ••• Maximum power for maximum productivity on your toughest jobs
- S** S-mode ••• Ideal balance of productivity and fuel efficiency for a range of urban engineering projects
- E** ECO-mode ••• Minimum fuel consumption for utility projects and other work that demands precision

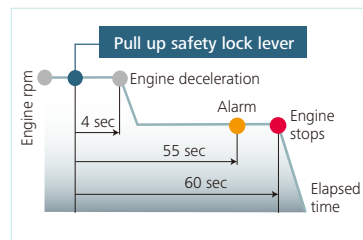

### AIS (Auto Idle Stop)

If the boarding/disembarking lever is left up, the engine will stop automatically. This eliminates wasteful idling during standby, saving fuel and reducing CO<sub>2</sub> emissions as well.

### Hydraulic system engineered to reduce energy loss

Kobelco's proprietary hydraulic systems offer hydraulic line positioning that reduces friction resistance and valves designed for higher efficiency, minimizing energy loss throughout the system.

### Always and forever. Yesterday, today, and tomorrow. We're obsessed with fuel efficiency

Over the past 8 years, KOBELCO has achieved an average fuel consumption reduction of 21% across its fleet. We vow to lead the industry in improving fuel efficiency.

■ Compared to SK135SR-2 model (2008)

**E** ECO-mode (SK140SR-05) ••• About **21%** improvement

## Ideal for Urban Work Sites Provides a Broad Working Range, Even in Close Quarters

### Minimal swing radius improves efficiency

The tail of the upper body extends very little past the back end of the crawlers, so the operator can concentrate on the job at hand. This also reduces the risk of collision damage.

### Easy workability in less than 12' 9" of space

The compact design allows continuous 180° dig, swing, and load operations within a working space of just.

### Seamless feeling, smooth combined operations

The machines have inherited the various systems that make inching and combined operations easy and accurate. Leveling and other combined operations can be carried out with graceful ease.

### Swing operation cuts cycle times

11.0rpm speedy cycle times. Dig, swing, load operations—continuous operation makes any task faster.

### Strong drawbar pulling force produces powerful travel capabilities

These new excavators handle steep slopes and rough roads with ease while ensuring smooth changes in direction.

### Drawbar pulling force: 31,000lbf

### Excellent Working Ranges

Greater working ranges with class-topping vertical digging depth.

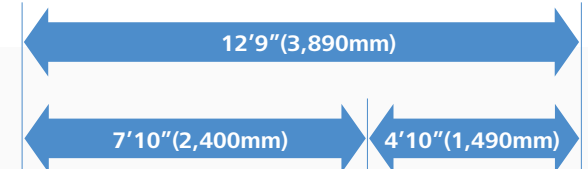
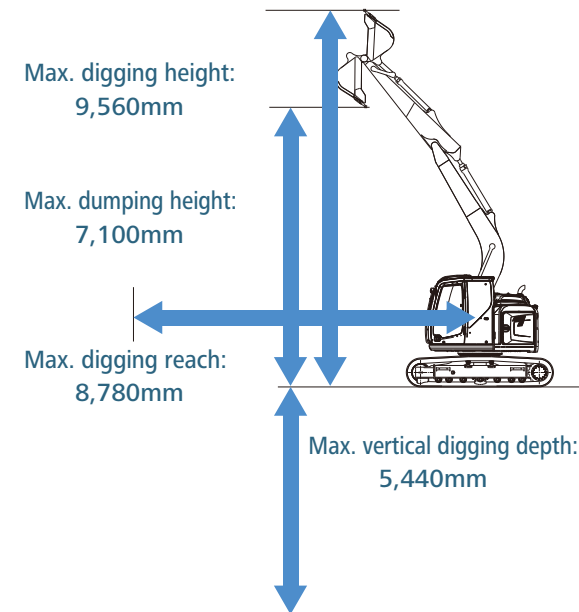

### Independent Travel

Selecting Independent Travel dedicates one hydraulic pump to travel and one to the attachment on a continuous basis, allowing for a smooth and constant movement speed even while swinging or using the boom or attachment. With Independent Travel, safely carrying a large pipe across a job site is a breeze.

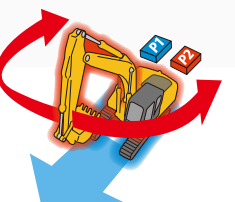

# Comprehensive safety and intuitive operation

User-friendly design and enhanced safety means greater efficiency and productivity.

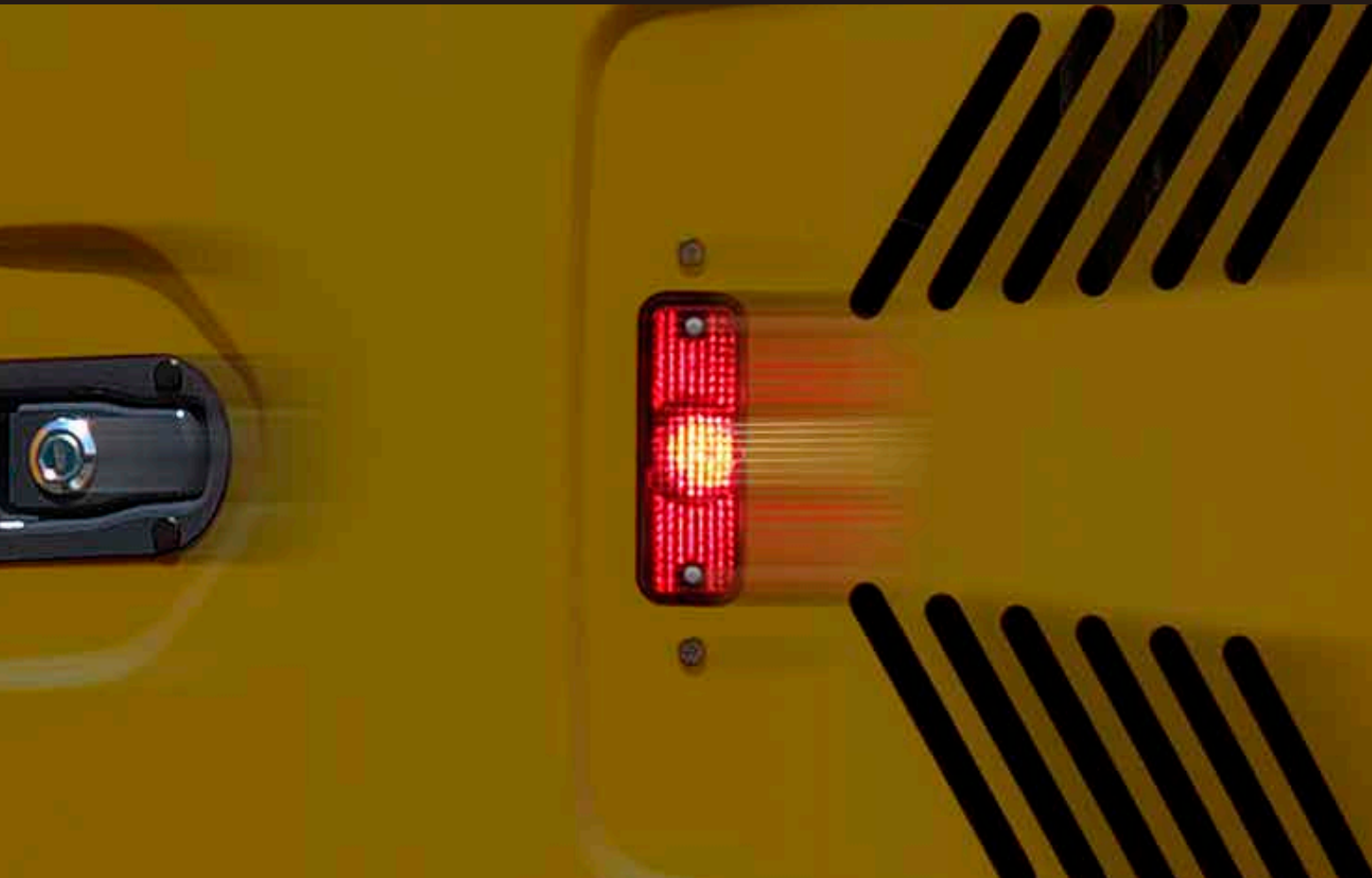

## Safety

### ROPS cab

ROPS (Roll-Over-Protective Structure)-compliant cab clears ISO standards (ISO-12117-2: 2008) and ensures greater safety for the operator should the machine tip over.



Standard FOPS, Top Guard Level II. (Meets ISO10262)



Mounting brackets for vandalism guards are standard equipment (contact your KOBELCO dealer to fit vandalism or front rock guards).

### Expanded field of view for greater safety



Left and right rear-view mirrors/Right bottom clearance mirror



Rear view from cab

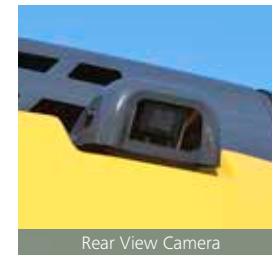

Rear View Camera

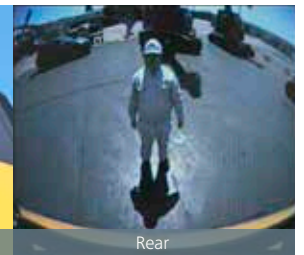

Rear

### Option right side camera **NEW**



Rear swing flashers



Emergency escape hammer



Right Side Camera Monitor Rear Right

## Operator-friendly Features Include Controls that Are Easy to See, Easy to Use



### Multi-display in color

Brilliant colors and graphic displays are easy to recognize on the LCD multi-display in the console. The display shows fuel consumption, maintenance intervals, and more.

- 1 Analog gauge provides an intuitive reading of fuel level and engine water temperature
- 2 Green indicator light shows low fuel consumption during operation
- 3 DEF tank level gauge
- 4 Fuel consumption/Switch indicator for rear camera images
- 5 Digging mode switch
- 6 Monitor display switch

### One-touch attachment mode switch

A simple flick of a switch converts the hydraulic circuit and flow amount to match attachment changes. Icons help the operator to confirm the proper configuration at a glance.



DEF tank level gauge

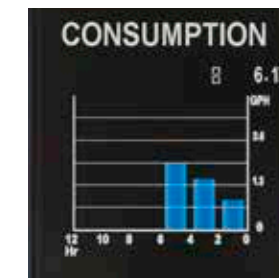

Fuel consumption



Maintenance



Breaker mode

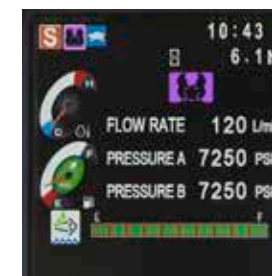

Nibbler mode

# Cab Design That Puts the Operator First

Wide and open, the cab's interior overflows with features that streamline operation

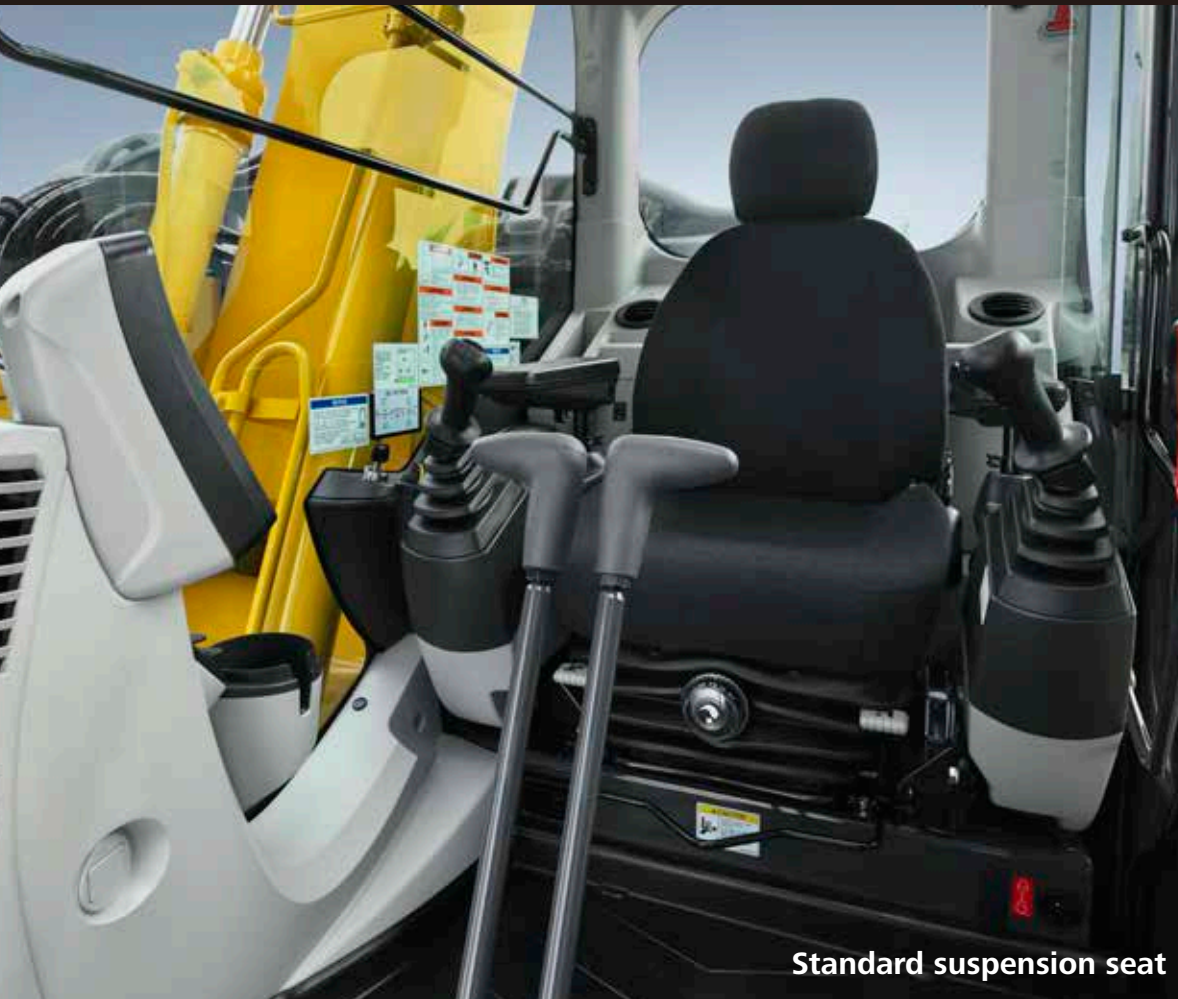

Standard suspension seat



## Comfort

### Big roomy cab

The cube design makes the most of straight lines, so the cab interior is 4% more spacious than before. Operating space literally spreads out before the operator. And the 50Pa airtightness keeps dust outside.

### Wide doors and ample head clearance mean smooth entry and exit

The control box and safety lock lever tilt up at a larger angle, and the door handle height is positioned for easy cab entry and exit.

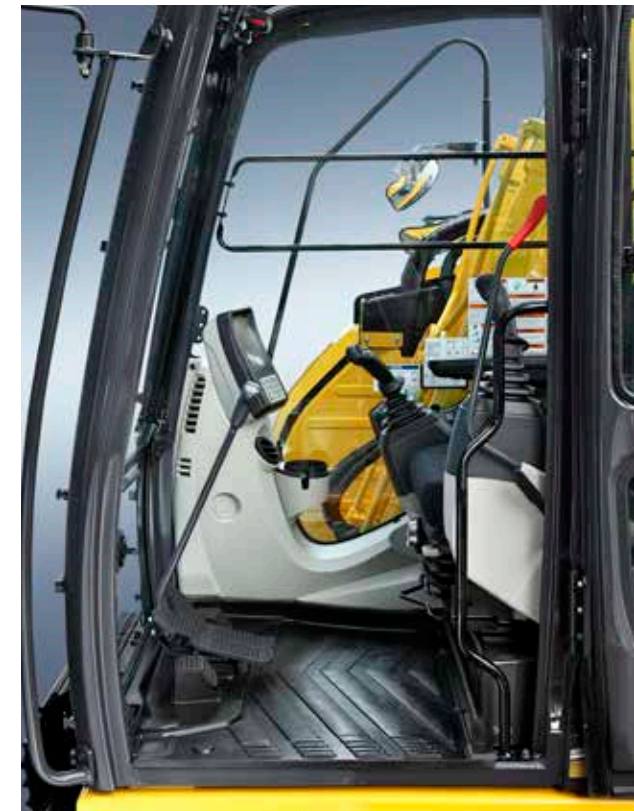

### More comfortable seat means higher productivity

The cube design makes the most of straight lines, so the cab interior is 4% more spacious than before. Operating space literally spreads out before the operator. And the 50Pa airtightness keeps dust outside.



Seat suspension absorbs vibration



Seat recliner can be pushed back flat

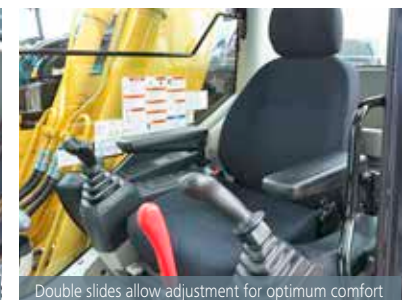

Double slides allow adjustment for optimum comfort

### Wide-open field of view

On the right side, the large single window has no center pillar, and the whole cab is designed for a wide field of view, giving the operator a direct view ahead and to the left and right. Mirrors in three positions make it easy for the operator to see around the machine.

### Equipment designed for comfort and convenience

The cab interior offers a host of operator comforts. The seat guarantees comfort whether on the job or at rest, and everything is ergonomically planned and laid out for smooth, stress-free operation.



### Bluetooth installed **NEW** radio

Bluetooth installed to allow connections with iPhones and other devices.



### Powerful automatic air conditioner

Also standard is an automatic air conditioner that maintains a comfortable interior environment all year around.



Spacious storage tray



Large cup holder



USB connector



12V power outlet

# Proper Maintenance Ensures Peak Efficiency

Kobelco machines are designed for quick, simple inspection and maintenance.



## Machine Information Display Function

- Displays only the maintenance information that's needed, when it's needed
- Self-diagnostic function provides early-warning detection and display of any possible electrical issues
- Service-diagnostic function makes it easier to check the status of the machine
- Record function of previous maintenance issues including irregular and transient malfunction

Maintenance information display

# Quality that Keeps on Shining. Valuable Assets Take Your Business to the Next Level.

Structural strength and proven reliability mean these machines can deal with heavy work loads and perform in rigorous site environments. From the lifecycle viewpoint, these machines maintain their value throughout their service lives.



## Easy, on-the-spot maintenance NEW



**Urea tank**  
Urea filler cap is placed on the step for easy access.



**Engine maintenance**  
A special lower access step, near the engine, simplifies maintenance.



**Handhold**  
The handrail on the boom side allows easy access to the top of the machinery deck.

## Maintenance work, daily checks, etc., can be done from ground level

The layout allows for easy access from the ground for many daily checks and regular maintenance tasks.



Engine oil filter



Hydraulic pump

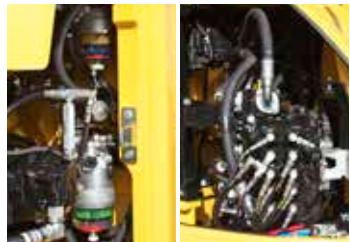

Fuel water separator/Fuel filter/Control valve



iNDr filter/radiator reservoir tank/air cleaner

## Fast maintenance requires only a few procedures



Washer fluid tank is located under the cab floor mat.



Engine oil quick-drain valve can be turned without, special tools.



Fuel tank features bottom flange and large drain valve for easy maintenance.

## Improved Filtration System Reliability

Clean, contaminant-free fuel and hydraulic fluid are essential to stable performance. The improved filtration systems reduce the risk of mechanical trouble and enhance longevity and durability.

### Hydraulic fluid filter NEW

Recognized as the best in the industry, our super-fine filter separates out even the smallest particles. New cover prevents contamination when changing filters.



### Hydraulic fluid filter clog detector NEW

Pressure sensors at the inlet and outlet of the hydraulic fluid filter monitor differences in pressure to determine the degree of clogging. If the difference in pressure exceeds a predetermined level, a warning appears on the multi-display, so any contamination can be removed from the filter before it reaches the hydraulic fluid reservoir.

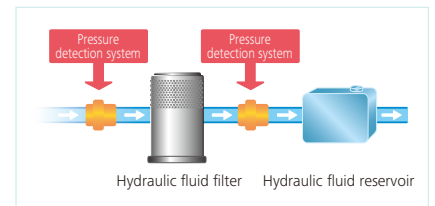

### Enlarged fuel filter NEW

The enlarged fuel filter with built-in water separator maximizes filtering performance.

60% enlarged

### Easy cleaning saves time



Detachable two-piece floor mat has handles for easy removal. The mat's raised edges trap dirt and grit for easy cleaning.



Special crawler frame design makes it easy to clean off mud.



### Double-element air cleaner

The large-capacity element features a double-filter structure that keeps the engine protected under the most demanding job conditions and backed up with an audible filter clog alarm in the operator's cab.

Long-life hydraulic oil:  
**5,000** hours

Replacement cycle:  
**1,000** hours

### Long-interval maintenance

Long-life hydraulic oil reduces cost and labor.

### Highly durable super-fine filter

The high-capacity hydraulic oil filter incorporates glass fiber with superior cleaning power and durability.



### Remote monitoring for peace of mind

KOMEXS (Kobelco Monitoring Excavator System) uses satellite communication and internet to relay data, and therefore can be deployed in areas where other forms of communication are difficult.

When a hydraulic excavator is fitted with this system, data on the machine's operation, such as operating hours, location, fuel consumption, and maintenance status can be obtained remotely.

### Direct Access to Operational Status

#### Location data

• Accurate location data can be obtained even from sites where communications are difficult.



Latest location



Location records



Work data

### Operating hours

• A comparison of operating times of machines at multiple locations shows which locations are busier and more profitable.  
• Operating hours on site can be accurately recorded, for running time calculations needed for rental machines, etc.

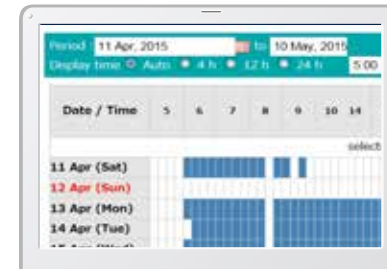

Daily report

### Fuel consumption data

• Data on fuel consumption and idling times can be used to indicate improvements in fuel consumption.

Work mode	Working Hrs	Total Fuel Consumption
H mode	2:06	24.5 L
S mode	0:00	0.0 L
E mode	169:19	1489.7 L
<b>TOTAL</b>	<b>171:25</b>	<b>1514.2 L</b>

Fuel consumption

### Graph of work content

• The graph shows how working hours are divided among different operating categories, including digging, idling, traveling and optional operations.

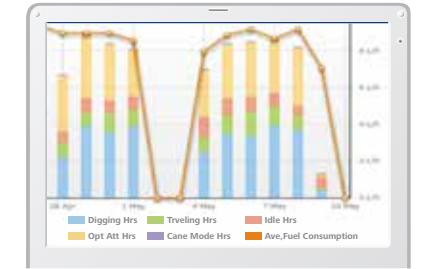

Work status

### Maintenance Data and Warning Alerts

#### Machine maintenance data

• Provides maintenance status of separate machines operating at multiple sites.  
• Maintenance data is also relayed to KOBELCO service personnel, for more efficient planning of periodic servicing.

Model	Serial No.	Hour Meter	Engine Oil
SK135RCL-3/SK140RCL	YH07-09221	734 Hr	434
SK135RCL-3/SK140RCL	YH07-09289	73 Hr	429
SK210LC-9	YQ11-10454	960 Hr	58
SK210LC-9	YQ11-10481	540 Hr	490
SK75SR-	Y708-30374		

Maintenance

#### Warning alerts

• This system warns an alert if an anomaly is sensed, preventing damage that could result in machine downtime.

### Alarm information can be received through E-mail

• Alarm information or maintenance notice can be received through E-mail, using a computer or cell phone.



### Daily/Monthly reports

• Operational data downloaded onto a computer helps in formulating daily and monthly reports.

### Security system

#### Engine start alarm

• The system can transmit and alarm, if the machine is operated outside designated time.

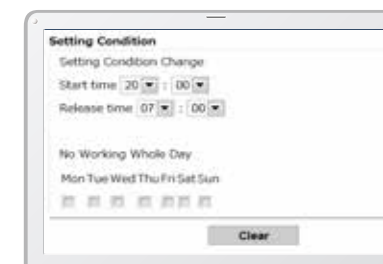

Engine start alarm outside prescribed work time

#### Area alarm

• The system can transmit and alarm, if the machine is moved out of its designated area to another location.



Alarm for outside of reset area



## Engine

Model	ISUZU AR-4JJ1XASK-02
Type	4 cycle, water cooled, overhead valve, vertical in-line, direct injection type, with turbo-charger. Tier IV certified.
No. of cylinders	4
Bore and stroke	3.75" (95.4 mm) x 4.13" (104.9 mm)
Displacement	183.0 cu.in (2.999 L)
Rated power output	(SAE NET) 95.6 hp {71.3 kw} / 2,000 rpm (Without fan) 105.3 hp {78.5 kw} / 2,000 rpm
Max. torque	(SAE NET) 256 lb-ft {347 N•m} / 1,800 rpm (Without fan) 277 lb-ft {375 N•m} / 1,800 rpm

## Hydraulic System

Pump	
Type	Two variable displacement piston pumps
Max. discharge flow	2 x 34.3 US · gpm {2 x 130 L/min} 1 x 5.3 US · gpm {1 x 20 L/min}
Relief valve setting	
Excavating circuits (main)	4,970 psi {34.3 Mpa}
Travel circuit	4,970 psi {34.3 Mpa}
Swing circuit	4,060 psi {28.0 Mpa}
Pilot control circuit	725 psi {5.0 Mpa}
Pilot control pump	Gear type
Main control valve	8-spool
Oil cooler	Air cooled type

## Swing System

Swing motor	axial piston motor
Parking brake	Oil disk brake, hydraulic operated automatically
Swing speed	11.0 rpm {11.0 min <sup>-1</sup> }
Swing torque	29,400 lb•ft {39.9kN•m} (SAE)
Tail swing radius	4'11" {1,490mm}
Min. front swing radius	7'10" {2,400mm}

## Attachments

Backhoe bucket and combination

Bucket Duty	Capacity (SAE) cu yd {m <sup>3</sup> }	Width in {m}	Bucket Weight lb {kg}	Arm 9' 4" {2.84 m}
General	0.30 {0.229}	18 {0.457}	650 {296}	H
	0.44 {0.336}	24 {0.609}	720 {327}	H
	0.58 {0.443}	30 {0.762}	835 {379}	M
	0.73 {0.558}	36 {0.914}	905 {411}	L
	0.88 {0.672}	42 {1.066}	1,015 {460}	L
Heavy Duty	0.30 {0.229}	18 {0.457}	705 {320}	H
	0.44 {0.336}	24 {0.609}	780 {354}	H
	0.58 {0.443}	30 {0.762}	900 {408}	M
	0.73 {0.558}	36 {0.914}	975 {442}	L
	0.88 {0.672}	42 {1.066}	1,090 {494}	X

H: Used with material weight up to 3,000 lb/cu yd (1,780 kg/m<sup>3</sup>)  
M: Used with material weight up to 2,500 lb/cu yd (1,483 kg/m<sup>3</sup>)  
L: Used with material weight up to 2,000 lb/cu yd (1,186 kg/m<sup>3</sup>)  
X: Not recommended

## Travel System

Travel motors	2 x axial piston, two-speed motors
Travel brakes	Hydraulic brake per motor
Parking brakes	Oil disk brake per motor
Travel shoes	46 each side
Travel speed	3.5 / 2.1 mph {5.6 / 3.4 km/h}
Drawbar pulling force	31,000 lbs {138 kN} (SAE J 1309)
Gradeability	70% {35°}

## Cab & Control

Cab	
All-weather, sound-suppressed steel cab mounted on the silicon-sealed viscous mounts and equipped with a heavy, insulated floor mat.	
Control	
Two hand levers and two foot pedals for travel	
Two hand levers for excavating and swing	
Electric rotary-type engine throttle	

## Boom, Arm & Bucket

Boom cylinders	3.9" {100 mm} x 3'7" {1,092 mm}
Arm cylinder	4.5" {115 mm} x 3'8" {1,120 mm}
Bucket cylinder	3.7" {95 mm} x 3'0" {903 mm}

## Dozer Blade (Optional)

Dozer cylinder	4.3" {110 mm} x 8.7" {220 mm}
Dimension	8'6" {2,590 mm} (width) x 1'11" {575 mm} (height)
Working range	1'8" {500 mm} (up) x 1'11" {585 mm} (down)

## Refilling Capacities & Lubrications

Fuel tank	50.2 U.S.gal {190 L}
Cooling system	2.38 U.S.gal {9.0 L}
Engine oil	3.43 U.S.gal {13.0 L}
Travel reduction gear	2x0.55 U.S.gal {2 x 2.1 L}
Swing reduction gear	0.44 U.S.gal {1.65 L}
Hydraulic oil tank	"21.0 U.S.gal {79.3 L} tank oil level 44.4 U.S.gal {168.0 L} hydraulic system"
DEF/AdBlue tank	9.0 U.S.gal {33.9 L}

## Working Ranges

Unit: ft-in{m}

Boom	15'4" {4.68m}
Range	9'4" {2.84m}
a- Max. digging reach	28'10" {8.78}
b- Max. digging reach at ground level	28'4" {8.64}
c- Max. digging depth	19'7" {5.98}
d- Max. digging height	31'4" {9.56}
e- Max. dumping clearance	23'4" {7.10}
f- Min. dumping clearance	7'3" {2.22}
g- Max. vertical wall digging depth	17'10" {5.44}
h- Min. swing radius	7'10" {2.40}
i- Horizontal digging stroke at ground level	15'5" {4.70}
j- Digging depth for 8 feet flat bottom	19'0" {5.79}
Bucket capacity ISO heaped m <sup>3</sup>	0.50 {0.38}

## Digging Force

Unit: lbs {kN}

Arm length	9'4" {2.84m}
Bucket digging force	SAE 20,500 {91.2}
	ISO 21,357 {95.0}
Arm crowding force	SAE 12,700 {56.7}
	ISO 13,100 {58.1}

## Dimensions

Unit: ft-in{mm}

Arm length	9'4" {2.84m}
A Overall length	24'7" {7,500}
B Overall height (to top of boom)	10'2" {3,110}
C Overall width of crawler	8'6" {2,590}**
D Overall height (to top of cab)	9'5" {2,860}
E Ground clearance of rear end*	33.7" {855}
F Ground clearance*	17.3" {440}
G Tail swing radius	4'11" {1,490}

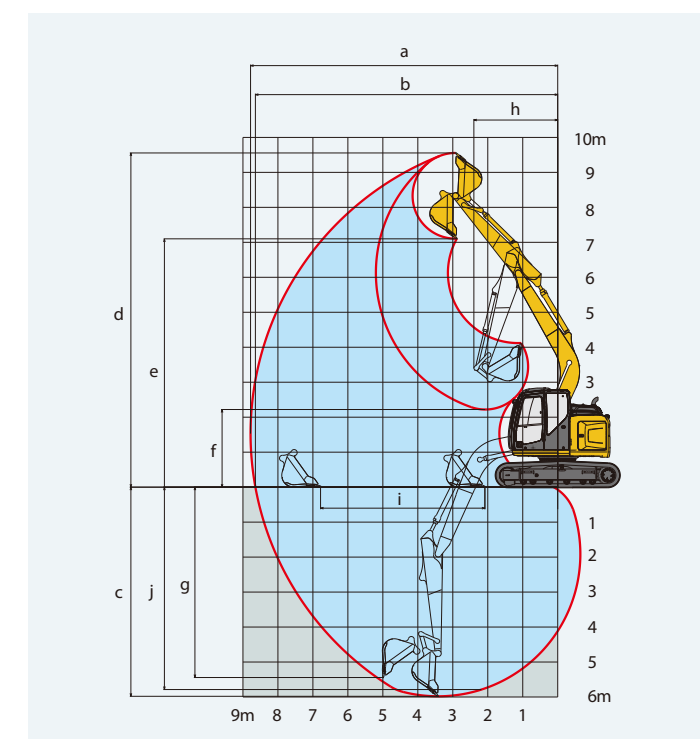

Unit: ft-in{mm}

G' Distance from center of swing to rear end	4'11" {1,490}
H Tumbler distance	10'0" {3,040}
I Overall length of crawler	12'4" {3,750}
J Track gauge	6'6" {1,990}
K Shoe width	19.7" {500} / 23.6" {600} / 27.6" {700}
L Overall width of upperstructure	8'2" {2,490}

\* Without including height of shoelug.  
\*\* Shoe width : 23.6" {600mm}

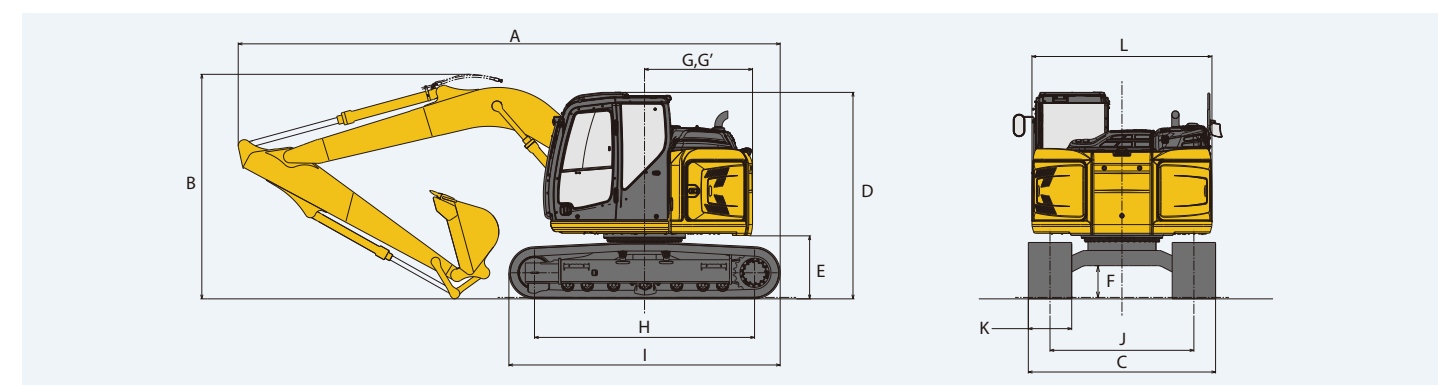

## Operating Weight & Ground Pressure

In standard trim, with standard boom, 9'4" {2.84m} arm, and 0.5 cu.yd. {0.38m<sup>3</sup>} SAE heaped bucket

Shaped	Triple grouser shoes (even height)			
Shoe width	inches {mm}	19.7" {500}	23.6" {600}	27.6" {700}
Overall width of crawler	ft-in {mm}	8'2" {2,490}	8'6" {2,590}	8'10" {2,690}
Ground pressure	psi {kPa}	6.1 {42}	5.2 {36}	4.5 {31}
Operating weight	lbs {kg}	30,900 {14,000}	31,500 {14,300}	32,000 {14,500}

## Optional Configuration

Ground pressure with Dozer	psi {kPa}	6.5 {45}	5.5 {38}	4.8 {33}
Operating weight with Dozer	lbs {kg}	33,300 {15,100}	34,000 {15,400}	34,400 {15,600}

## Offset Boom Specifications

### Dimensions

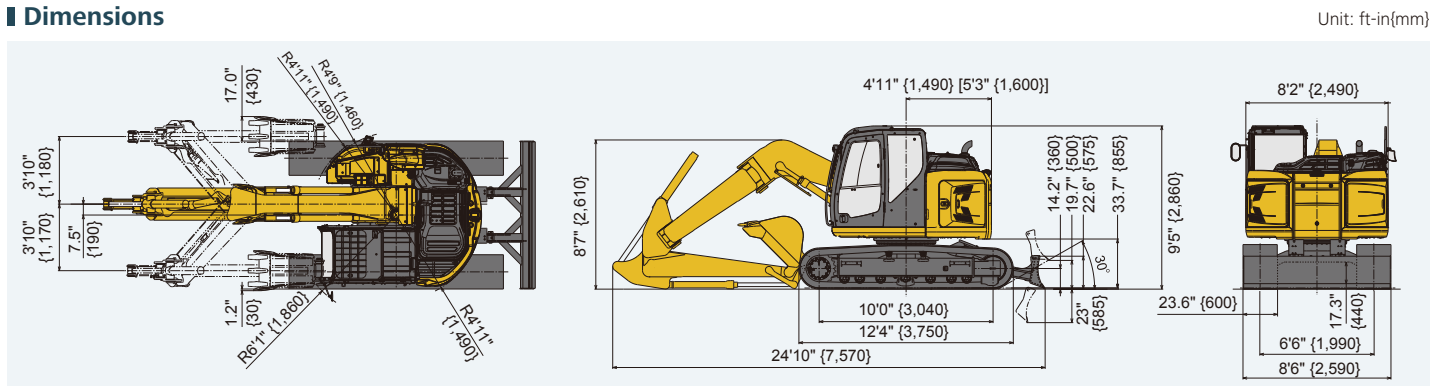

[ ] With add-on type counterweight

### Working Ranges

Boom	Offset Boom Specification		
	8'2" (2.50m)		
Arm Offset	Max. Left	Center	Max. Right
a- Max. digging reach	24'4" (7,410)	25'8" (7,830)	24'3" (7,400)
b- Max. digging reach at ground level	23'9" (7,250)	25'2" (7,680)	23'9" (7,230)
c- Max. digging depth	15'10" (4,820)	17'2" (5,220)	15'9" (4,800)
d- Max. digging height	26'2" (7,970)	27'3" (8,310)	26'1" (7,960)
e- Max. dumping clearance	18'4" (5,590)	19'5" (5,930)	18'3" (5,570)
f- Min. dumping clearance	5'10" (1,780)	6'11" (2,120)	5'10" (1,770)
g- Max. vertical wall digging depth	11'7" (3,540)	12'10" (3,900)	11'7" (3,530)
h- Min. swing radius	6'3" (1,900)	5'10" (1,790)	6'11" (2,110)
Bucket capacity SAE heaped cu.yd.(m <sup>3</sup> )	0.50 (0.38)		

### Operating Weight & Ground Pressure

#### Offset Boom Configuration

Shaped	inches (mm)	Triple grouser shoes (even height)		
		19.7" (500)	23.6" (600)	27.6" (700)
Shoe width				
Overall width of crawler	ft-in (mm)	8'2" (2,490)	8'6" (2,590)	8'10" (2,690)
Ground pressure	psi (kPa)	6.25 (43)	5.26 (37)	4.69 (32)
Operating weight	lbs (kg)	32,000 (14,500)	32,600 (14,800)	33,100 (15,000)

#### Optional Configuration

Ground pressure with dozer	psi (kPa)	6.82 (47)	5.68 (40)	4.97 (34)
Operating weight with dozer	lbs (kg)	34,400 (15,600)	35,100 (15,900)	35,500 (16,100)

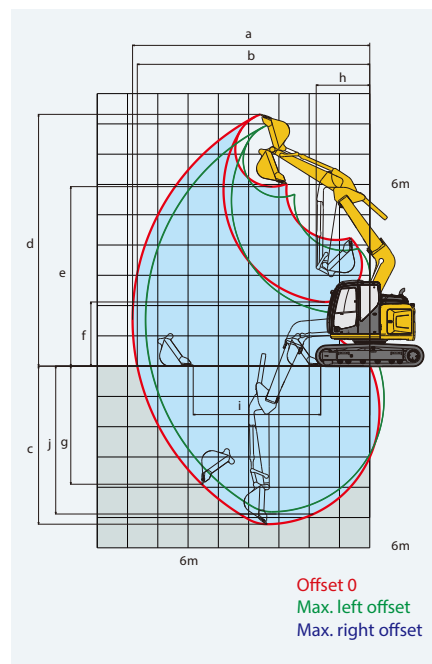

### Lifting Capacity

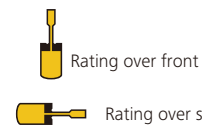
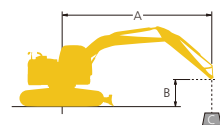

Rating over side or 360 degrees

A - Reach from swing centerline for bucket hook  
B - Bucket hook height above/below ground  
C - Lifting capacities in pounds  
Relief valve setting : 4,970 psi (34.3 MPa)

SK140SR <sub>LC</sub>	Arm: 9'4" (2.84m) Bucket: Less Counterweight: 6,920lbs(3,140kg) Shoe: 23'6" (600m) Dozer: Less											
	A		5' (1.5m)		10' (3.0m)		15' (4.6m)		20' (6.1m)		At Max. Reach	
B	lb(kg)	lb(kg)	lb(kg)	lb(kg)	lb(kg)	lb(kg)	lb(kg)	lb(kg)	lb(kg)	lb(kg)	lb(kg)	
25' (7.6m)										*4,630 (2,100)	*4,630 (2,100)	14'2" (4.31m)
20' (6.1m)										*3,740 (1,690)	*3,740 (1,690)	19'7" (5.97m)
15' (4.6m)										*3,460 (1,560)	*3,460 (1,560)	22'7" (6.90m)
10' (3.0m)										*3,430 (1,550)	3,170 (1,430)	24'3" (7.40m)
5' (1.5m)										*3,590 (1,620)	2,960 (1,340)	24'9" (7.55m)
G.L.										*3,980 (1,800)	2,990 (1,350)	24'3" (7.39m)
-5' (-1.5m)										*4,780 (2,160)	3,290 (1,490)	22'6" (6.87m)
-10' (-3.0m)										*6,590 (2,980)	4,120 (1,860)	19'5" (5.92m)
-15' (-4.6m)										*5,740 (2,600)	*5,740 (2,600)	13'10" (4.23m)

SK140SR <sub>LC</sub>	Arm: 9'4" (2.84m) Bucket: Less Counterweight: 8,200lbs(3,720kg) Shoe: 23'6" (600m) Dozer: Less											
	A		5' (1.5m)		10' (3.0m)		15' (4.6m)		20' (6.1m)		At Max. Reach	
B	lb(kg)	lb(kg)	lb(kg)	lb(kg)	lb(kg)	lb(kg)	lb(kg)	lb(kg)	lb(kg)	lb(kg)	lb(kg)	
25' (7.6m)												14'2" (4.31m)
20' (6.1m)												19'7" (5.97m)
15' (4.6m)												22'7" (6.90m)
10' (3.0m)												24'3" (7.40m)
5' (1.5m)												24'9" (7.55m)
G.L.												24'3" (7.39m)
-5' (-1.5m)												22'6" (6.87m)
-10' (-3.0m)												19'5" (5.92m)
-15' (-4.6m)												13'10" (4.23m)

SK140SR <sub>LC</sub>	Arm: 9'4" (2.84m) Bucket: Less Counterweight: 8,200lbs(3,720kg) Shoe: 23'6" (600m) Dozer: blade down											
	A		5' (1.5m)		10' (3.0m)		15' (4.6m)		20' (6.1m)		At Max. Reach	
B	lb(kg)	lb(kg)	lb(kg)	lb(kg)	lb(kg)	lb(kg)	lb(kg)	lb(kg)	lb(kg)	lb(kg)	lb(kg)	
25' (7.6m)												14'2" (4.31m)
20' (6.1m)												19'7" (5.97m)
15' (4.6m)												22'7" (6.90m)
10' (3.0m)												24'3" (7.40m)
5' (1.5m)												24'9" (7.55m)
G.L.												24'3" (7.39m)
-5' (-1.5m)												22'6" (6.87m)
-10' (-3.0m)												19'5" (5.92m)
-15' (-4.6m)												13'10" (4.23m)

SK140SR <sub>LC</sub>	Offset boom Arm: 8'2" (2.50m) Bucket: Less Counterweight: 6,920lbs(3,140kg) Shoe: 23'6" (600m) Dozer: Less											
	A		5' (1.5m)		10' (3.0m)		15' (4.6m)		20' (6.1m)		At Max. Reach	
B	lb(kg)	lb(kg)	lb(kg)	lb(kg)	lb(kg)	lb(kg)	lb(kg)	lb(kg)	lb(kg)	lb(kg)	lb(kg)	
20' (6.1m)												15'4" (4.69m)
15' (4.6m)												19'2" (5.84m)
10' (3.0m)												21'1" (6.42m)
5' (1.5m)												21'8" (6.60m)
G.L.												21'0" (6.41m)
-5' (-1.5m)												19'0" (5.81m)
-10' (-3.0m)												15'2" (4.63m)

#### Notes:

- Do not attempt to lift or hold any load that is greater than these lift capacities at their specified lift point radius and heights. Weight of all accessories must be deducted from the above lift capacities.
- Lift capacities are based on machine standing on level, firm, and uniform ground. User must make allowance for job conditions such as soft or uneven ground, out of level conditions, side loads, sudden stopping of loads, hazardous conditions, experience of personnel, etc.
- Arm top defined as lift point.
- The above lifting capacities are in compliance with ISO 10567. They do not exceed 87% of hydraulic lifting capacity or 75% of tipping load. Lifting capacities marked with an asterisk (\*) are limited by hydraulic capacity rather than tipping load.
- Operator should be fully acquainted with the Operator's and Maintenance Instructions before operating this machine. Rules for safe operation of equipment should be adhered to at all times.
- Lift capacities apply to only machine as originally manufactured and normally equipped by KOBELCO CONSTRUCTION MACHINERY CO., LTD.