

HYDRAULIC EXCAVATOR

**takeuchi**

*From World First to World Leader*

# TB2150



# Product Features & Specifications

## ENGINE

- EPA Final Tier 4 Emission Compliant
- Turbocharged
- High Pressure Common Rail Fuel Injection
- DOC+SCR Exhaust After Treatment
- Automatic Fuel Bleed System
- Dual Element Air Cleaner
- Automatic Deceleration
- Working Modes: Standard, Power and High Altitude
- Automatic Belt Tensioner
- Variable Speed Hydraulic Fan Drive
- High Efficiency Fuel Filters
- Automatic Preheat

## ELECTRICAL

- 7" Multi-Informational Display
- Sealed Rocker Switches
- Rear View Camera
- Beacon Socket and Lamp Switch
- Hour Meter
- Deluxe LED Light Package
- Side Halogen Work Lights
- Travel Alarm
- Horn

## UNDERCARRIAGE AND FRAME

- Triple Flanged Track Rollers
- 2-Speed Travel with Automatic Shift
- High Torque Planetary Final Drive
- Heavy Duty Dozer Blade with Float
- Wrap Around Counterweight
- 20" Rubber Tracks
- 24" Steel Tracks (optional)
- Segmental Rubber Crawlers (optional)

## OPERATOR'S STATION

- Cab with Air Conditioner, Heat Defrost, Windshield Wiper and Washer, Polycarbonate Skylight with Sunshade, AM / FM / MP3 Radio, 24v and 12v Power Outlet
- ROPS / OPG Level 2 Protection
- Deluxe High Back Air Ride Suspension Seat with Heat
- Adjustable Arm Rests
- 2" Retractable Seat Belt
- Roof Guard
- Front Window Guard (optional)

## TAKEUCHI FLEET MANAGEMENT

- Minimize Downtime
- Remote Diagnostics
- Utilization Tracking
- Proactive Maintenance
- Control Costs

## HYDRAULIC & WORKING EQUIPMENT

- Variable Displacement, Open Center Hydraulics
- Independent Boom Swing
- Cushioned Boom and Arm Cylinders
- Hydraulic Pilot Controls
- Proportional Auxiliary Controls with Detent
- Adjustable Auxiliary Flow
- Dual Boom Cylinders
- Primary and Secondary Auxiliary Hydraulic Circuit Plumbed to Arm
- High Pressure Third Auxiliary Circuit
- Multiple Attachment Presets
- Flow Selector Valve, Primary Auxiliary Circuit
- Pattern Change Valve (ISO or SAE)
- High Capacity Hydraulic Oil Cooler
- Pilot Accumulator
- Long Arm
- Arm and Boom Holding Valve with Lift Alarm
- Pin Grabber Bucket Coupler (optional)
- Main Pin Hydraulic Thumb (optional)



Outstanding Visibility



Automotive Styled Interior

# TOUGH, POWERFUL, RELIABLE



**Large Floor with Foot Rest**



**Wraparound Counterweight**



**Independent Boom Swing**

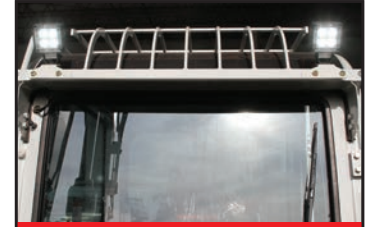

**LED Work Lights**

The TB2150 is the largest, most capable excavator in the Takeuchi line-up. It is completely redesigned and delivers improved functionality, performance, comfort, and serviceability.

A new EPA Final Tier 4 emission compliant Deutz TCD 3.6 liter, turbocharged engine produces 114 horsepower and 339 ft-lb of torque. This engine utilizes a DOC+SCR diesel exhaust after-treatment system and has no DPF for less maintenance.

The operator's station features an automotive styled interior that is refined and operator friendly. The spacious cabin features a deluxe high back air

suspension seat with heat, and a new 7" color multi-information display that keeps the operator informed of machine health and performance. For greater peace of mind, the TB2150 includes boom and arm holding valves, an overload alarm, and rearview camera which will help the operator see objects behind the machine via the new color monitor.

Additionally, telematics are now standard equipment using the Takeuchi Fleet Management System or TFM. This system is standard equipment for two years and it will provide real time machine information and enable the dealer and owner to be proactive with a scheduled maintenance program.



**Large lockable service hoods provide vandalism protection and outstanding maintenance access.**

## OPERATING PERFORMANCE

Operating Weight - Cab (Rubber)	34,480 lb	(15,640 kg)
Cab (Steel)	35,109 lb	(15,925 kg)
Maximum Bucket Breakout Force	22,190 lb	(10,065 kg)
Maximum Arm Digging Force	12,557 lb	(5,696 kg)
Arm Length	8 ft 5.0 in	(2,570 mm)
Slew Speed	10.8 rpm	
Traction Force	32,600 lb	(14,786 kg)
Ground Pressure - Cab (Rubber)	6.83 psi	(47.1 kPa)
Cab (Steel)	6.92 psi	(47.7 kPa)
Max Travel Speed		
Low Range	1.9 mph	(3.1 km / hr)
High Range	3.4 mph	(5.5 km / hr)

## HYDRAULIC SYSTEM

Total Hydraulic Flow	78.9 gpm	(293.0 Lpm)
Auxiliary Flow - Primary Circuit	59.0 gpm	(224.0 Lpm)
Auxiliary Flow - Secondary Circuit	14.5 gpm	(55.0 Lpm)
Hydraulic System Pressure	4,977 psi	(34.3 MPa)

## ENGINE

Make / Model	Deutz / TCD 3.6 L4 - Turbo	
Displacement	221.0 cu in	(3.6 L)
Horsepower @ 2,000 rpm	114.0 hp	(85.0 kW)
Maximum Torque @ 1,600 rpm	339.3 ft-lb	(460.0 Nm)

## FLUID CAPACITIES

Engine Lubrication	10.6 qt	(10.0 L)
Cooling System	21.1 qt	(20.0 L)
Fuel Tank Capacity	73.4 gal	(278.0 L)
Fuel Consumption (65% of Full Load)	3.84 gal / hr	(14.5 L / hr)
Hydraulic Reservoir Capacity	28.1 gal	(107.0 L)
Hydraulic System Capacity	42.3 gal	(160.0 L)



LCD Display



Rear View Camera



Dozer Blade with Float



Auxiliary Hydraulic Lines

## TB2150 Lifting Capacities\*

Lift Point Radius from Rotation Axis		12 ft (3,657 mm)	16 ft (4,876 mm)	
	Lifting Capacities Over Front, Blade Down	4 ft Above Ground	16,782 lb (7,612 kg)	10,883 lb (4,936 kg)
		Ground Level	17,124 lb (7,767 kg)	12,199 lb (5,533 kg)
		4 ft Below Ground	18,415 lb (8,352 kg)	12,467 lb (5,654 kg)
	Lifting Capacities Over Side	4 ft Above Ground	11,182 lb (5,072 kg)	7,481 lb (3,393 kg)
		Ground Level	10,796 lb (4,896 kg)	7,215 lb (3,272 kg)
		4 ft Below Ground	10,712 lb (4,858 kg)	7,105 lb (3,222 kg)

\* Ratings based on ISO10567 and do not exceed 87% of hydraulic lift or 75% of tipping load.

\*Check Operators Manual for Full Range Specs

## ATTACHMENTS

Takeuchi now offers attachments for all of your Takeuchi equipment. See your authorized Takeuchi dealer for additional information and attachment options.

# TB2150 Compact Excavator

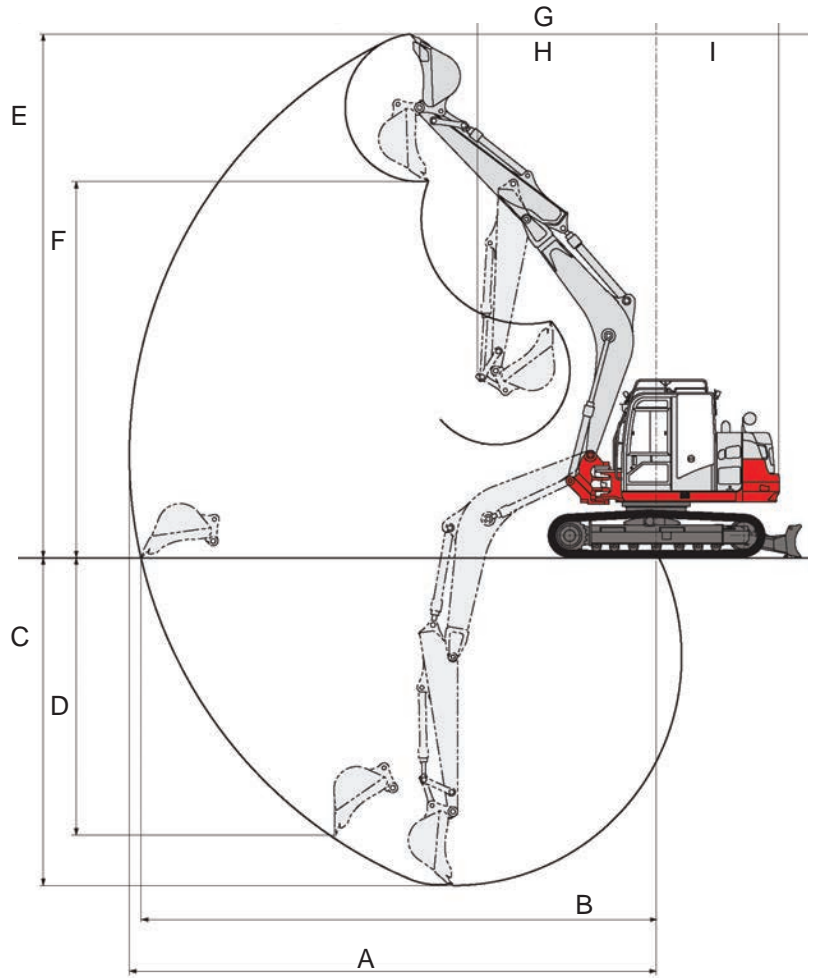
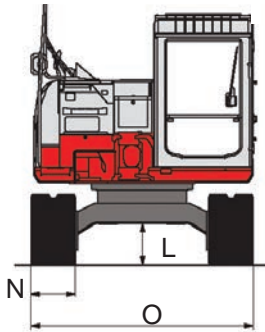
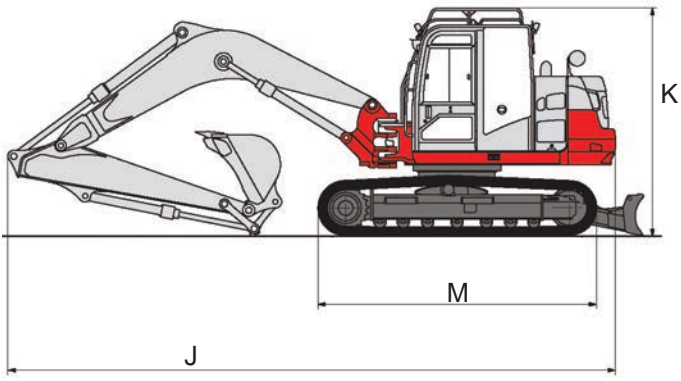

## MACHINE DIMENSIONS

A	Maximum Reach	28 ft 8.9 in	(8,760 mm)
B	Maximum Reach at Ground Level	28 ft 1.0 in	(8,565 mm)
C	Maximum Digging Depth	18 ft 0.0 in	(5,486 mm)
D	Maximum Vertical Digging Depth	15 ft 2.5 in	(4,635 mm)
E	Maximum Dig Height	28 ft 5.0 in	(8,670 mm)
F	Maximum Dumping Height	20 ft 4.9 in	(6,220 mm)
G	Front Swing Radius	9 ft 11.0 in	(3,015 mm)
H	Front Swing Radius with Boom Offset	7 ft 10.0 in	(2,405 mm)
I	Slew Radius	6 ft 6.7 in	(2,000 mm)
J	Transport Length	25 ft 7.3 in	(7,805 mm)
K	Transport Height	9 ft 8.5 in	(2,960 mm)
L	Ground Clearance	1 ft 7.0 in	(475 mm)
M	Track Overall Length	11 ft 10.3 in	(3,615 mm)
N	Track Width (Rubber)	20.0 in	(500 mm)
O	Track Overall Width	8 ft 2.0 in	(2,490 mm)



**2 YEAR**  
**2,000 HOUR**  
**FULL MACHINE**  
**WARRANTY**



© 2017 Takeuchi Manufacturing (U.S.), Ltd. All Rights Reserved. Printed in the U.S.A. In accordance with our established policy of continued improvement, specifications and features are subject to change without notice. Pictures may show options other than standard equipment.

FORM: TB2150 Compact Excavator Spec Sheet - May 2017

**TAKEUCHI**  
*From World First to World Leader*