

Specifications

OPERATING PERFORMANCE

Operating Weight

Standard Machine with Bucket, CaB

Operating Weight	10,582 lbs (4,800 kg)
Tipping Load, Straight	8,073 lbs (3,800 kg)
Tipping Load, Full Turn	7,143 lbs (3,240 kg)
Rated Operating Capacity, SAE J818*	3,572 lbs (1,620 kg)
Bucket Breakout Force	11,600 lbs (5,262 kg)
Lift Arm Breakout Force	10,319 lbs (4,680 kg)
Traction Force	9,217 lbs (4,180 kg)
Cycle Time	
Raise Full Load	5.8 Seconds
Lower No Load	3.5 Seconds
Dump Full Load	1.7 Seconds

*Operating capacity is 50% of full turn tipping load with bucket. According to SAE J818

ENGINE

Make / Model	Deutz/TD2011 Turbo
Tier Rating	Interim Tier 4
Cylinders / Displacement	4/221 cu in (3.62 L)
Horsepower Gross (SAE J1995)	69 hp (51.3 Kw)
Horsepower Net (SAE J1349)	67 hp (50 Kw)
Rated Engine Speed	2200 rpm
Maximum Torque	177 ft-lb @ 1600 rpm (240 Nm)
Engine Lubrication	11.6 qt (11 L)
Fuel Tank Capacity	26.4 gal (100 L)
Fuel Consumption, 65% of full load)	2.5 gal/hr (9.5 L/hr)
Electrical System	12 volts/80 amps

DRIVE TRAIN

Transmission Type	Hydrostatic Drive with 100% Hydraulic Inching Pedal
Axle Type	Rigid Axles with Outboard Planetary Reduction
Differential Lock	100% Differential Lock in Front and Rear Axles
Parking Brake	Spring Applied, Hydraulically Released, Multiple Wet Friction Disc
Service Brakes	Hydraulic + Multi Wet Friction Disc
Steering Articulation	40° Left / 40° Right
Frame Articulation	12° Left / 12° Right
Maximum Travel Speed (mph)	
Low	4 mph (6.5 km/hr)
High	12.4 mph (20 km/hr)

HYDRAULIC

Hydraulic Reservoir Capacity	13.7 gal (52 L)
Auxiliary Hydraulic Flow	15.8 gal/min (60 L/min)
System Operating Pressure	3,844 psi (26.5 mpa)



WORKING DIMENSIONS

A. Overall Operating Height	13 ft 0 in (3,960 mm)
B. Maximum Lift Height to Bucket Pin	10 ft 4.6 in (3,165 mm)
C. Bucket Clearance Height	9 ft 2 in (2,800 mm)
D. Dump Height Fully Raised	8 ft 1 in (2,465 mm)
E. Maximum Dump Angle Fully Raised	45°
F. Reach Fully Raised	2 ft 0 in (625 mm)
G. Maximum Bucket Rollback at Ground	48°
H. Maximum Cut	13 in (80 mm)

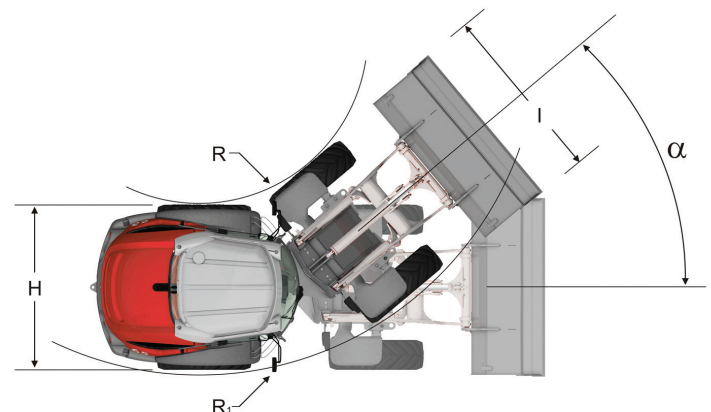

MACHINE DIMENSIONS

A. Wheelbase	6 ft 6.7 in (2,000 mm)
B. Outside Turning Radius Over Tire	12 ft 2 in (3,715 mm)
C. Overall Height	8 ft 9 in (2,662 mm)
D. Overall Width without Bucket	6 ft 1.5 in (1,870 mm)
E. Recommended Bucket	1.05 yd ³ (.80 m ³)
F. Overall Length with Bucket	17 ft 3 in (5,250 mm)
G. Ground Clearance	1 ft 5.7 in (450 mm)

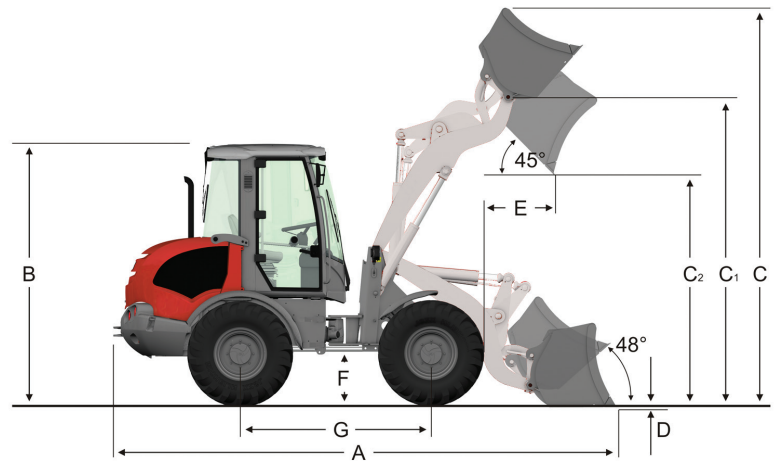

Product Features

ENGINE

- ◆ EPA Interim Tier 4 Compliant
- ◆ Oil Cooled
- ◆ Turbocharged
- ◆ Dual Element Air Cleaner with Restriction Indicator
- ◆ High Capacity Engine Oil Cooler

ELECTRICAL

- ◆ Electronic Engine Monitoring System with Fuel Gauge, High Beam Indicator, Turn Signal Indicators, High Speed Indicator
- ◆ 12 volt System with 80 amp Alternator
- ◆ Work Lights, Front and Rear
- ◆ Driving Lights and Turn Signals
- ◆ Directional Lights Fwd/Rev
- ◆ Engine Preheat
- ◆ Back-Up Alarm

DRIVE TRAIN

- ◆ Hydrostatic Drive with 100% Inching Pedal
- ◆ 100% Locking Differentials, Front and Rear
- ◆ Outboard Planetary Drives
- ◆ Two Speed Travel
- Heavy Duty Construction Tire Assembly (Option)
- Floatation Tire Assembly (Option)

HYDRAULIC

- ◆ Precise and Responsive Pilot Controls
- ◆ Auxiliary Hydraulic Lines Plumbed to the End of the Loader Arms
- ◆ Auxiliary Hydraulic Detent
- ◆ Hydraulic System Test Ports
- ◆ Hydraulic Oil Level Sight Gauge
- ◆ Remote mounted Hydraulic Oil Cooler

◆ - Standard

○ - Optional

WORKING EQUIPMENT

- ◆ Z-Bar Linkage Provides Excellent Loader Performance
- ◆ Powerful Bucket and Lift Arm Breakout Forces Equal Outstanding Productivity
- ◆ Bucket Float Function
- ◆ Mechanical Bucket Positioning
- ◆ Heavy Duty Hydraulic Bucket Quick Coupler
- ◆ Heavy Duty Self Aligning Loader Bushings with Oversized Pins
- 77" Construction Combo Bucket (1.05 yd³)
- Combo Hitch to Universal SSL Adaptor
- HD 48" Pallet Forks and Frame
- TW Series Coupler Kit

OPERATOR'S STATION

- ◆ Spacious Operator's Cab Provides ISO Certified
- ◆ ROPS/FOPS Level 2 Protection for Added Peace of Mind
- ◆ 2 in Retractable Seat Belt
- ◆ Suspension Seat with Arm Rests
- ◆ Front and Rear Wipers, Rear Window Defrost, and Heater
- ◆ Large Steps and Grab Handles Provide Easy Entry and Exit
- ◆ Elevated Operator's Station Provides Outstanding Visibility
- ◆ Multi-Function Joystick for Machine Direction
- Fwd/Rev and Loader Controls: Raise, Lower, Curl, Dump
- Air Conditioner
- 3" Seat Belt