

Skid Steer Loaders

- TS50R
- TS50V
- TS60R
- TS60V
- TS70R
- TS70V



TAKEUCHI

US Headquarters
Pendergrass, Georgia
706.693.3600
sales@takeuchi-us.com

www.takeuchi-us.com

TAKEUCHI

Those in the know, know Takeuchi

© 2012 Takeuchi Manufacturing (U.S.), Ltd. All Rights Reserved. Printed in the U.S.A. In accordance with our established policy of continued improvement, specifications and features are subject to change without notice. Pictures of skid steer loaders may show optional equipment. Pictures and illustrations may not represent final color scheme and decal placement.
FORM: Skid Steer Loader FB Nov. 2012

Takeuchi Skid Steer Loaders



Power and Reliability

Compact Skid Steer Loaders

Takeuchi provides a wide range of skid steer loaders that are sure to meet your needs. Whether you are removing snow, loading trucks, unloading pallets, working construction, or doing road and bridge work, Takeuchi has the radial or vertical lift path skid steer to help complete your toughest tasks.

Takeuchi skid steers provide an outstanding blend of power and performance, durability and operator comfort. All Takeuchi skid steers feature class leading ground clearance and angle of departure, high travel speeds, excellent tractive effort, and powerful digging forces.

When you purchase a Takeuchi skid steer loader you can operate with confidence knowing that you are backed by an industry leader with over five decades of innovation and know how.

You also receive our full support and commitment to keeping your Takeuchi skid steer loader in prime operating condition through our broad distribution network of dealers and service centers.

Radial Lift

TS50R



TS60R



TS70R



Vertical Lift

TS50V



TS60V



TS70V



Performance

Takeuchi skid steer loaders have many performance driven features to help you complete the many demanding tasks you face each day in the field. These powerful skid steers feature rugged engines that provide outstanding power and economy in a small package. The TS50R and TS50V feature a naturally aspirated engine that delivers 50 hp, while the TS60R, TS60V, TS70R, and TS70V all feature powerful and efficient turbocharged engines that deliver up to 74 hp. The power you need to tackle those demanding jobs is delivered through a load-sensing, pilot controlled drive system that helps keep the machine operating at maximum efficiency while the high axle torque allows you to excavate, grade, and push harder to pile material ensuring a full bucket with each pass.

A mechanical quick attach is standard equipment and simplifies attachment installation and removal. For the ultimate in convenience a fully hydraulic quick attach is also available. An auxiliary detent switch provides continuous hydraulic flow for a variety of attachments reducing fatigue making you more productive. Bucket float is activated by pushing the attachment control lever fully forward into the detent position allowing you to back drag with ease and efficiency.

To improve productivity around large work sites, Takeuchi skid steer loaders provide a standard speed of up to 8.5 mph and offer an optional 2-speed feature that delivers an impressive 12 mph travel speed. For special applications where you need a narrower footprint, the wheels can be easily reversed on the machine to narrow the width by up to 6 inches. When more traction is needed, the specially designed loader arms provide clearance for over the tire tracks without the need for spacers or special wheels.



The high capacity fuel tank reduces downtime and allows you to spend more time working.

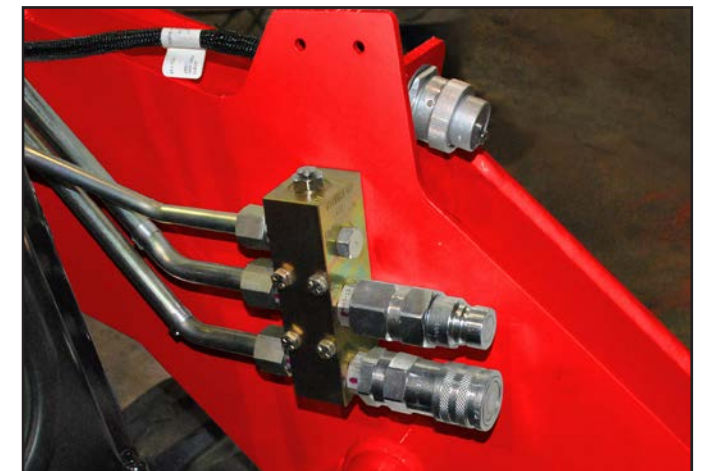

Pressure relieving attachment couplers and an available attachment control kit make Takeuchi skid steers very versatile.



Great axle torque combined with excellent travel speeds provide the productivity you demand.

Durability

Unlike much of the competition using a two piece skid steer frame, the Takeuchi skid steer frame is a one piece, all welded purpose built frame designed to withstand many punishing hours in the field.

Hydrostatic drive systems feature spring applied, hydraulically released, multiple wet friction disk parking brakes for outstanding holding power.

Mechanical faced axle seals are standard equipment on Takeuchi skid steer loaders and will provide you with many hours of reliable service by keeping out dust, sand, debris, and other contaminants. The drive system also uses heavy duty sprockets and chains, providing many hours of dependable service.

The cooling module features a side-by-side radiator and oil cooler that ensures clean fresh air reaches each component allowing the machine to run cooler and more efficiently. Steel lines are used extensively throughout the skid steer loaders for greater durability and peace of mind.

A rear bumper is also found on all Takeuchi skid steer loaders adding an additional layer of protection to the rear of the machine. Large, easily accessible anchor points are also found on the rear bumper allowing you to simply and safely secure your machine for transport.

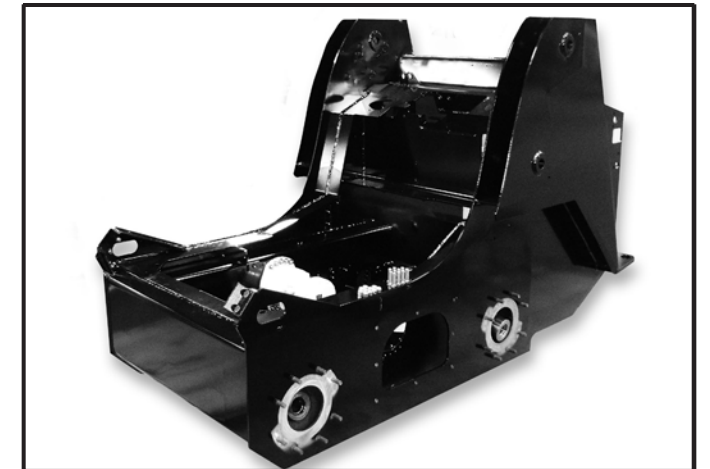

All welded, one-piece frame provides superior durability and balance.

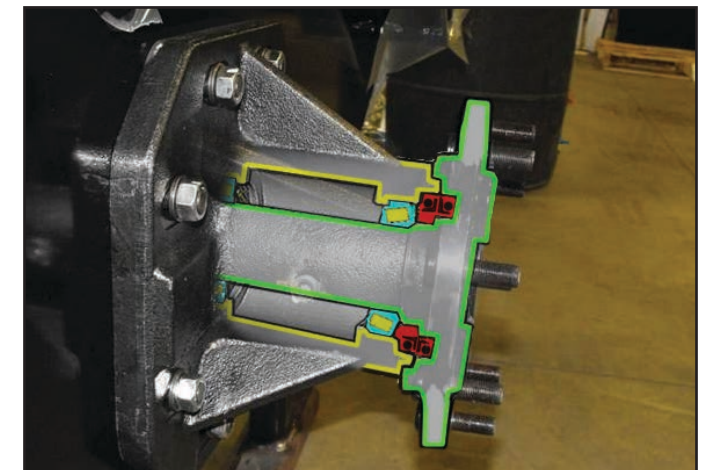

Heavy duty axles equipped with mechanical face axle seals along with large chains and sprockets provide many hours of reliable service.



The large rear bumper provides protection for the rear of the machine and the large anchor points make it easy to secure the machine for transport.

Operator Comfort

A spacious and well-appointed operator's station allows you to spend many hours in the field with little fatigue. Low effort pilot controlled joysticks are responsive and low effort making you more efficient and comfortable while you work.

Also standard is the foot throttle which allows you to set or change the engine speed without taking your hands off the controls.

A critical component for any skid steer loader is visibility around the machine and to the attachment edge. Due to their low tower design, Takeuchi skid steer loaders provide you with outstanding visibility to the side and rear of the machine. The design of the vertical lift arrangement on the TS50V and TS60V places the torque tube out of your line of sight allowing you to operate with confidence.

Standard safety features add additional value and include front and rear halogen work lights, a rearview mirror, a back-up alarm, and a non-skid safety step. A 12v power supply is standard equipment allowing you to keep your cell phone, radio, and other electronic devices fully charged.

Pressurized cabs are available and feature a variety of options including heat only, or air conditioning and heat to ensure your comfort throughout the year. The low profile A/C system helps protect the unit from damage without blocking critical sight lines.



Large gauges and easy to operate switches are easily seen and contribute to the exceptional visibility found in Takeuchi skid steer loaders.



Low effort pilot controlled joysticks are responsive while the foot throttle helps to improve the efficiency of the machine.



The low profile A/C system helps protect the unit from damage without blocking critical sight lines.

Serviceability

Easy access to service points saves you valuable time and money. All Takeuchi skid steer loaders feature a tilt back operator's station providing outstanding access to hydraulic and engine components.

The side-by-side cooling module is mounted to the rear door making it simple to inspect and clean. If you require access to both sides of the cooling module simply remove two bolts allowing it to swing free of the door.

All daily fluid checks are easily accessible through the rear door making inspection and maintenance straight forward and efficient.

Jump starting the machine is easy with the remote battery terminal on the 50 and 60 series machines, and the convenient battery location on the 70 series machines.

Takeuchi is recognized for delivering powerful, dependable, field proven compact construction machinery, and we are confident that our latest skid steer loaders will continue this tradition. With our established dealer network, you can be assured that you will receive outstanding service, support, value, and our commitment to you and your success.



Easy to access service points allow for efficient machine maintenance and inspection.



The cab tilts back to reveal quality components in an efficient layout. Steel lines improve serviceability and help dissipate heat.



The side-by-side cooling module swings out with the rear door and hinges open for easy cleaning and inspection of both sides of the radiator and oil cooler.

Specifications

	TS50R	TS50V	TS60R	TS60V	TS70R	TS70V
OPERATING PERFORMANCE						
Loader Type	Radial	Veritcal	Radial	Veritcal	Radial	Veritcal
Operating Weight - Canopy	6,475 lbs (2,937 kg)	6,981 lbs (3,167 kg)	6,480 lbs (2,939 kg)	6,986 lbs (3,169 kg)	7,450 lbs (3,379 kg)	8,100 lbs (3,674 kg)
Tipping Load	3,000 lbs (1,361 kg)	4,000 lbs (1,814 kg)	3,000 lbs (1,361 kg)	4,000 lbs (1,814 kg)	3,987 lbs (1,808 kg)	5,270 lbs (2,594 kg)
Rated Operating Capacity, SAE J818*	1,500 lbs (680 kg)	2,000 lbs (907 kg)	1,500 lbs (680 kg)	2,000 lbs (907 kg)	2,000 lbs (907 kg)	2,653 lbs (1,203 kg)
Bucket Breakout Force	3,900 lbs (1,769 kg)	4,130 lbs (1,873 kg)	3,900 lbs (1,770 kg)	4,130 lbs (1,873 kg)	5,500 lbs (2,494 kg)	5,878 lbs (2,666 kg)
Lift Arm Breakout Force	3,000 lbs (1,360 kg)	3,675 lbs (1,667 kg)	3,000 lbs (1,360 kg)	3,675 lbs (1,667 kg)	7,000 lbs (3,175 kg)	5,871 lbs (2,663 kg)
Traction Force	8,453 lbs (3,834 kg)	8,453 lbs (3,834 kg)	8,453 lbs (3,834 kg)	8,453 lbs (3,834 kg)	8,700 lbs (3,946 kg)	8,700 lbs (3,946 kg)

*Operating capacity of skid steer loaders is rated according to SAE J818 at no more than 50% of the tipping load.

	TS50R	TS50V	TS60R	TS60V	TS70R	TS70V
ENGINE						
Make / Model	Perkins / 404D-22, Naturally Aspirated	Perkins / 404D-22, Naturally Aspirated	Perkins / 404D-22T, Turbocharged	Perkins / 404D-22T, Turbocharged	Perkins / 804D-33T, Turbocharged	Perkins / 804D-33T, Turbocharged
Cylinders / Displacement	4 / 135 cu in (2.2 L)	4 / 135 cu in (2.2 L)	4 / 135 cu in (2.2 L)	4 / 135 cu in (2.2 L)	4 / 201 cu in (3.3 L)	4 / 201 cu in (3.3 L)
Horsepower Gross	50 hp (37.3 kW)	50 hp (37.3 kW)	60 hp (44.7 kW)	60 hp (44.7 kW)	74 hp (55 kW)	74 hp (55 kW)
Rated Engine Speed	2,800 rpm	2,800 rpm	2,800 rpm	2,800 rpm	2,500 rpm	2,500 rpm
Maximum Torque	105 ft-lb (143 Nm)	105 ft-lb (143 Nm)	140 ft-lb (190 Nm)	140 ft-lb (190 Nm)	180 ft-lb (245 Nm)	180 ft-lb (245 Nm)
Engine Lubrication	11.2 qts (10.6 L)	11.2 qts (10.6 L)	11.2 qts (10.6 L)	11.2 qts (10.6 L)	9 qts (8.5 L)	9 qts (8.5 L)
Cooling System	14 qts (13.2 L)	14 qts (13.2 L)	14 qts (13.2 L)	14 qts (13.2 L)	12 qts (11 L)	12 qts (11 L)
Fuel Tank Capacity	25 gal (95 L)	25 gal (95 L)	25 gal (95 L)	25 gal (95 L)	30 gal (113 L)	30 gal (113 L)
Electrical System	12 volts / 65 amps	12 volts / 65 amps	12 volts / 65 amps	12 volts / 65 amps	12 Volts / 90 amps	12 volts / 90 amps

	TS50R	TS50V	TS60R	TS60V	TS70R	TS70V
DRIVE TRAIN AND FRAME						
Traction Drive Type	Hydrostatic	Hydrostatic	Hydrostatic	Hydrostatic	Hydrostatic	Hydrostatic
Chain Case	Bow Tie Drive System	Bow Tie Drive System	Bow Tie Drive System	Bow Tie Drive System	Bow Tie Drive System	Bow Tie Drive System
Chain Size	80 ANSI Chain	80 ANSI Chain	80 ANSI Chain	80 ANSI Chain	100 ANSI Chain	100 ANSI Chain
Wheel Size	10 x 16.5	10 x 16.5	10 x 16.5	10 x 16.5	12 x 16.5	12 x 16.5
Width Over Tires	66 in (1,676 mm)	66.5 in (1,689 mm)	66 in (1,676 mm)	66.5 in (1,689 mm)	72 in (1,828 mm)	72 in (1,829 mm)
Maximum Travel Speed:						
Single Speed	8.2 mph (13.2 km / hr)	8.2 mph (13.2 km / hr)	8.2 mph (13.2 km / hr)	8.2 mph (13.2 km / hr)	8.5 mph (13.6 km / hr)	8.5 mph (13.6 km / hr)
Optional 2-Speed	11.7 mph (18.8 km / hr)	11.7 mph (18.8 km / hr)	11.7 mph (18.8 km / hr)	11.7 mph (18.8 km / hr)	12 mph (19.3 km / hr)	12 mph (19.3 km / hr)

	TS50R	TS50V	TS60R	TS60V	TS70R	TS70V
HYDRAULIC SYSTEM						
Hydraulic Reservoir Capacity	8.0 gal (30.2 L)	8.0 gal (30.2 L)	8.0 gal (30.2 L)	8.0 gal (30.2 L)	10.0 gal (38 L)	10.0 gal (38 L)
Auxiliary Flow - Primary Circuit	17.1 gal / min (65 L / min)	17.1 gal / min (65 L / min)	17.1 gal / min (65 L / min)	17.1 gal / min (65 L / min)	21.5 gal / min (81 L / min)	28 gal / min (106 L / min)
Hydraulic System Pressure	3,335 psi (22.9 MPa)	3,335 psi (22.9 MPa)	3,335 psi (22.9 MPa)	3,335 psi (22.9 MPa)	3,335 psi (22.9 MPa)	3,335 psi (22.9 MPa)

	TS50R	TS50V	TS60R	TS60V	TS70R	TS70V
DIMENSIONS						
Maximum Lift Height to Bucket Pin	9 ft 7 in (2,921 mm)	9 ft 8 in (2,997 mm)	9 ft 7 in (2,921 mm)	9 ft 8 in (2,997 mm)	10 ft 5 in (3,175 mm)	10 ft 9 in (3,277 mm)
Dump Height Fully Raised	7 ft 3 in (2,210 mm)	7 ft 2.3 in (2,207 mm)	7 ft 3 in (2,210 mm)	7 ft 2.3 in (2,207 mm)	8 ft 5 in (2,570 mm)	8 ft 8 in (2,644 mm)
Dump Reach Fully Raised	1 ft 9.7 in (552 mm)	2 ft 5 in (762 mm)	1 ft 9.7 in (552 mm)	2 ft 5 in (762 mm)	2 ft 1.2 in (640 mm)	3 ft 0 in (914 mm)
Maximum Bucket Rollback at Ground	27°	26.7°	27°	26.7°	30°	30°
Maximum Dump Angle Fully Raised	40°	46.8°	40°	48.3°	34°	40°
Transport Length	11 ft 4.6 in (3,470 mm)	11 ft 4.4 in (3,465 mm)	11 ft 4.6 in (3,470 mm)	11 ft 4.4 in (3,465 mm)	11 ft 11.7 in (3,652 mm)	11 ft 11.8 in (3,653 mm)
Machine Length	8 ft 6.5 in (2,604 mm)	8 ft 11.2 in (2,723 mm)	8 ft 6.5 in (2,604 mm)	8 ft 11.2 in (2,723 mm)	9 ft 1.5 in (2,782 mm)	9 ft 0 in (2,764 mm)
Wheel Base	3 ft 4.6 in (1,031 mm)	3 ft 4.6 in (1,031 mm)	3 ft 4.6 in (1,031 mm)	3 ft 4.6 in (1,031 mm)	4 ft 0 in (1,242 mm)	4 ft 0 in (1,242 mm)
Angle of Departure	28°	28°	28°	28°	25.4°	25.5°
Ground Clearance	10.5 in (267 mm)	10.5 in (267 mm)	10.5 in (267 mm)	10.5 in (267 mm)	10.5 in (267 mm)	10.5 in (267 mm)
Overall Width - Wide Position	5 ft 6 in (1,676 mm)	5 ft 6.5 in (1,689 mm)	5 ft 6 in (1,676 mm)	5 ft 6.5 in (1,689 mm)	6 ft 0 in (1,828 mm)	6 ft 0 in (1,828 mm)
Overall Width - Wheel Reversed	5 ft 0 in (1,524 mm)	5 ft 0 in (1,524 mm)	5 ft 0 in (1,524 mm)	5 ft 0 in (1,524 mm)	5 ft 6 in (1,676 mm)	5 ft 6 in (1,676 mm)
Overall Height	6 ft 5 in (1,956 mm)	6 ft 5 in (1,956 mm)	6 ft 5 in (1,956 mm)	6 ft 5 in (1,956 mm)	7 ft 0 in (2,134 mm)	7 ft 0 in (2,134 mm)