

# TIMBERPRO

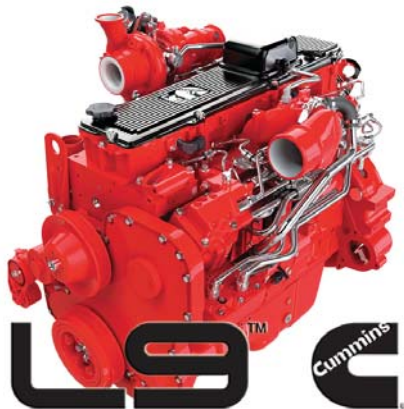

## L9 Engine Provides:

- 338 Hp @ 1800 RPM
- 1125 lb-ft Torque
- Better fuel economy with faster cycle times
- Tier 4F / Stage 5 Compliant



**8300**  
**8400**

# Stability, Strength and Versatility

The TimberPro 830D and 840D are the most versatile wheeled machines in the world today. The TimberPro line of machines come standard with 360° continuous rotation allowing the operator to always face his/her work. This feature also gives the operator the ability to remove or place timber from 360° around the machine. Including the option to work over the front of the machine just as well as the sides and rear. TimberPro machines have been proven effective in many other applications other than forwarding logs in the forest. Our machines can be used to move logs in mill yards, set mats in the pipeline industry, and most importantly as a combo machine equipped with a quick detach boom to allow conversion from a forwarder to a harvester in about 10 minutes.



TimberPro 840 fitted with a special dump body for removing jobsite debris and biomass.

TimberPro 840 with a custom grapple. Loading and transporting rig mats. Only machine on the market with full 360 degree rotation, allowing the operator to load, haul and set mats without driving off the matted surface.



## 840D CLAM BUNK SKIDDER (Optional)

Comparing TimberPro 840 Clam Bunk with Large Grapple Skidder

Travel time on 3600 ft. skid

	840	Grapple Skidder
Empty	9.0 min - 4.6 - M.P.H.	7.8 min - 5.3 - M.P.H.
Loaded	16.0 min - 2.6 - M.P.H.	10.5 min - 3.9 - M.P.H.
Loading and Turnaround	15.0 min	1.7 min
Total Round Trip Time	40 min	20 min
Average M.P.H.	3.6	4.6
Average Load	20 Tons	4 Tons

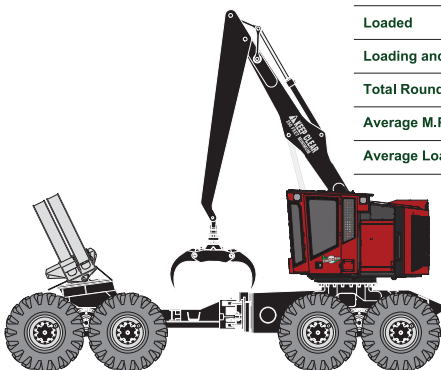

Optional Clam Bunk Attachment

Clam Bunk Capacity:  
32.4 ft<sup>2</sup> (2,97 m<sup>2</sup>)

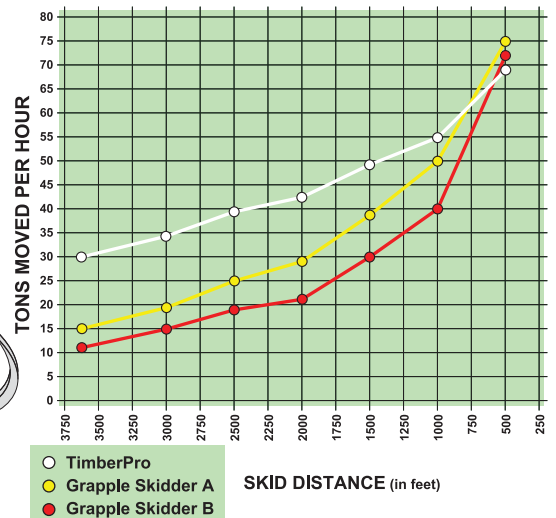
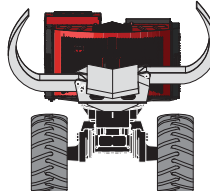

# Loaded with Features



Better Access to Control Valve

Better Access to Swing Motor

Front Platform for Service

Isolated Electrical Compartment for ease of service and added protection.



High-powered LED lighting

Large swing bearing w/continuous rotation

100 gallon fuel tank.

20 ton or 22 ton Bogie Axle, configured to allow front and rear axles to track perfectly even in the tightest turns

Shown with "optional" 6' squirt boom for 31.1' of reach or Feller buncher booms for heavy attachments.



Fully Customizable IQAN 10" MD4 HD Touch Screen Control System.

Integrated Cup holder, Cellphone Pocket, 12v Power Source and USB connection to Radio.

Multiple Seat Options for Operator Comfort

Air filtering system with pressurized cabin to reduce dust

(Optional) Hydraulic Front Step



# TIMBERPRO

Large comfortable cab with heated, air-ride seat, reduced noise levels, Rops, Ops, and Fops certified

Hinged headache rack allows boom to be lowered for transport

Bunks are Adjustable from 8'2" inside dimension to 9'10"



Heavy duty steel cast frame articulation joint with caliper frame lock

20 ton or 22 ton Bogie Axle, configured to allow front and rear axles to track perfectly even in the tightest turns

# Feature Options

ENGINE	830	840
Cummins L9 – 338 HP (Tier 4f compliant)	S	S
24 volt electrical system w/ 100 amp	S	S
Auto reversing hyd controlled rad fan	S	S
Espar Pre-heater with timer	O	O
120v AC Pre-heaters	O	O
HYDRAULICS	830	840
Parker control valves	S	S
IQAN MD4 10" HD control system	S	S
Rexroth axial piston pumps	S	S
55 gallon hyd oil reservoir	S	S
Hyd tank vacuum pump system	S	S
Electric hyd oil fill pump	S	S
Charge relief heater - Hydraulic oil	S	S
Hydrostatic closed loop drive circuits	S	S
Hydrostatic closed loop swing circuit	S	S
Continuous rotation swing	S	S
TIRES	830	840
710 / 45 x 26.5 ELS (TRS option available)	S	S
750 / 55 x 26.5 ELS or TRS	O	O
Firestone 28L (dual tires only)	O	O
AXLES & DRIVELINE	830	840
Axle Capacity in US Tons	20 T	22 T
Driveline - 8.5c with roller bearing joints	S	S
SAFETY FEATURES	830	840
ANSUL LVS / 110 Fire Suppression System (WET)	S	S
10 lb fire extinguisher	S	S

OPTIONS	830	840
Forward type boom (25' reach)	S	S
6' squirt for forwarder boom (+6' reach)	O	O
Quick change stick boom adapter	O	O
Feller buncher booms	O	O
Forestry booms with Live heel	O	O
Forwarder bunks and headache rack	O	O
Hultdins 360s grapple	O	O
Clam Bunk Attachment	O	O
26" Articulation Brake Disc	O	O
Hydraulic Front Blade	O	O
Hydraulic Front Frame Step	O	O
OPERATOR'S CAB	830	840
Fully certified for ROPS/FOPS/OPS	S	S
Three escape routes	S	S
½" lexan windows	S	S
1½" lexan in front window	O	O
Fresh air filtered & Pressurized cab	S	S
AM/FM/WB - Bluetooth radio - USB	S	S
Standard Seat - Air ride & Heated	S	S
Deluxe Seat - Air ride, Heat & Lumbar	O	O
Vented side window	S	S
High-powered LED lighting	S	S
Rear camera system	O	O

S = STANDARD ~ O = OPTIONAL ~ NA = NOT AVAILABLE

Rubber Belting Protection Added to Boom and Gullwing to Reduce Debris in Engine and Hydraulic Compartments.

Hydraulic componets easily accessible for service

Energy Recovering Hydrostatic Swing Pump



Cummins L9 Series Engine - 338HP with simple Single Module DOC/DPF/SCR unit

Easy Access to Major Components. (Starter, Alternator, Filters)

Gullwing Rear Door Provides Platform for Service.

# Specifications

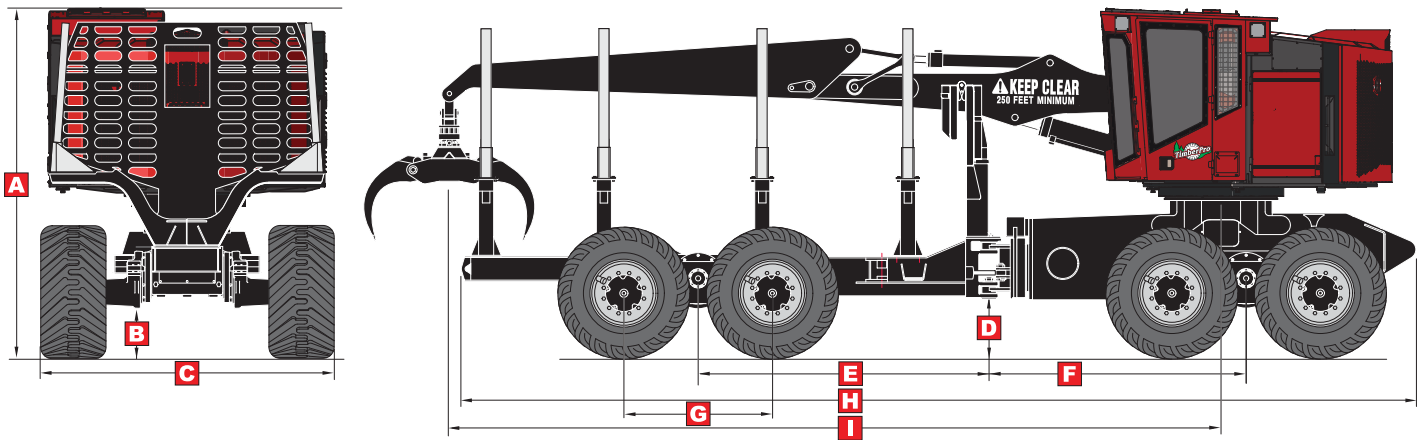

	Tire	830	840		830	840
<b>A)</b>	710	143" (363cm)	143" (363cm)	<b>E)</b>	111" (282cm)	111" (282cm)
	750	146" (371cm)	146" (371cm)		<b>F)</b>	107.5" (272cm)
<b>B)</b>	710	21" (53cm)	21" (53cm)	<b>G)</b>		66.5" (169cm)
	750	24" (61cm)	24" (61cm)		<b>H)</b>	385" (980cm)
<b>C) Narrow</b>	710	117" (297cm)	120" (304cm)	<b>I)</b>		306" (778cm)
	750	118" (300cm)	121" (307cm)			
<b>C) Wide</b>	710	128" (325cm)	131" (332cm)			
	750	129" (327cm)	132" (335cm)			
<b>D)</b>	710	24" (61cm)	24" (61cm)			
	750	27" (69cm)	27" (69cm)			

## BASE MACHINE WEIGHT (LBS)

	TOTAL	FRONT AXLE	REAR AXLE
830	57,100 (25,900 kg)	39,330 (17,826 kg)	17,770 (8,060 kg)
840	60,100 (27,260 kg)	41,396 (18,776 kg)	18,740 (8,500 kg)

## LIFT CAPACITY - forwarder

31.5'	6,320 lbs (2,867 kg)
25.5'	7,540 lbs (3,420 kg)
20'	11,320 lbs (5,135 kg)
15'	12,880 lbs (5,842 kg)

## LIFT CAPACITY - feller buncher

24'	10,800 lbs (4,899 kg)
20'	14,560 lbs (6,604 kg)
15'	22,200 lbs (10,070 kg)
10'	25,000 lbs (11,340 kg)

(Lift Capacities do not include attachment weight)

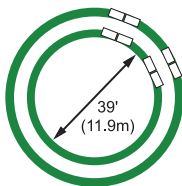

TimberPro's short wheelbase allows for a tight inside turning diameter of 39' (11.9m).

## BOOM SWEEP STANDARD FORWARDER

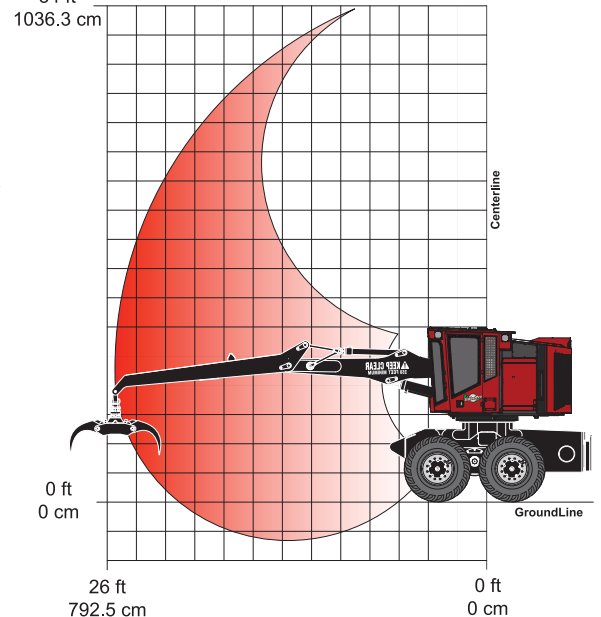

TimberPro Inc reserves the right to change specifications without notice or obligation. Product illustrations may be equipped with non-standard equipment.

TimberPro Inc.  
1407 Industrial Dr.  
Shawano WI 54166 USA  
www.timberpro.com